

7RAXIS

# WETBENCH

INSTRUCTION MANUAL

---

FOR THE ORIGINAL  
WETBENCH

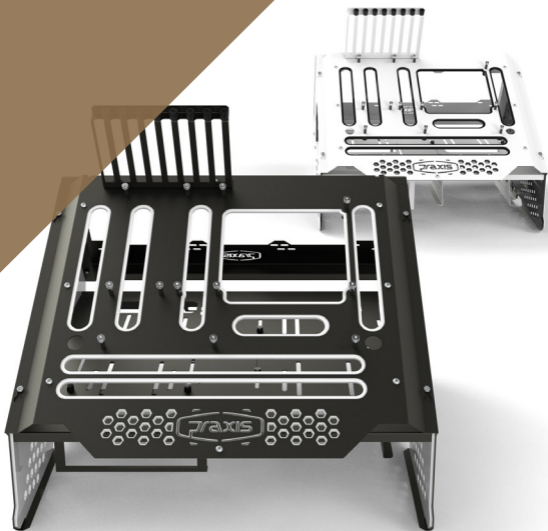

# CONTENTS

<b>INCLUDED MOUNTING HARDWARE .....</b>	<b>3</b>
<b>WETBENCH HARDWARE.....</b>	<b>4</b>
<b>ACRYLIC LEG INSTALL.....</b>	<b>5</b>
<b>LEG TO MIDTRAY INSTALL.....</b>	<b>6</b>
<b>HARD DRIVE TO MIDTRAY INSTALL.....</b>	<b>7</b>
<b>PSU INSTALL.....</b>	<b>8</b>
<b>OPTICAL DRIVE INSTALL.....</b>	<b>9</b>
<b>INSTALL OF MIDTRAY BRACKETS.....</b>	<b>10</b>
<b>ACRYLIC MOTHERBOARD INSTALL .....</b>	<b>11</b>
<b>MOTHERBOARD STANDOFF INSTALL.....</b>	<b>12</b>
<b>GPU BRACKET INSTALL.....</b>	<b>13</b>
<b>MOTHERBOARD TRAY INSTALL.....</b>	<b>14</b>
<b>MOTHERBOARD INSTALL .....</b>	<b>15</b>
<b>RADIATOR TRAY INSTALL .....</b>	<b>16</b>
<b>RADIATOR INSTALL.....</b>	<b>17</b>
<b>VANDAL SWITCH INSTALL.....</b>	<b>18</b>
<b>WETBENCH COMPATIBILITY.....</b>	<b>BACK</b>

# MOUNTING HARDWARE



PART #	PART NAME	QTY
1	M3 MOTHERBOARD NUT	24
2	M4X6 LOWHEAD SCREW	20
3	12MM MOTHERBOARD STANDOFF	14
4	M3 SPLIT WASHER	11
5	M3X10MM SOCKET CAP	11
6	M3x8MM GPU SCREWS	10
7	6/32 .25" HDD NYLON SCREW	14
8	M4X8MM MIDTRAY NYLON SCREW	10
9	M3x5MM SSD/DRIVE NYLON SCREW	14
10	M3 MOTHERBOARD SCREW	14
11	2.5MM HEX KEY WRENCH	1

# WETBENCH HARDWARE

ITEM #	PART NAME	QTY
1	MOTHERBOARD TRAY	1
2	MID TRAY	1
3	LEFT & RIGHT SLANTED LEGS	1
4	BACK RADIATOR TRAY	1
5	GPU BRACKET	1
6	FRONT AND BACK PSU BRACKET	1
7	5.25" BAY BRACKET	2
8	ACRYLIC INSERTS FOR LEGS	2
9	ACRYLIC INSERTS FOR MOTHERBOARD	1



1

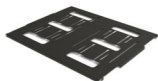

2



3



4



5



6



7



8



9

## STEP 1 | INSTALLING ACRYLIC TO LEGS

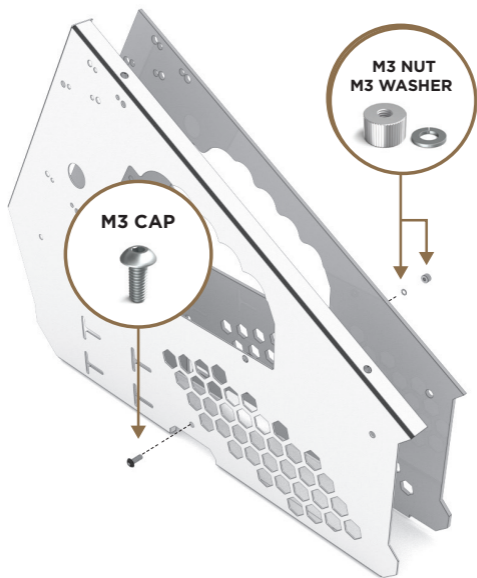

Grab your **leg** and **acrylic insert**. Be sure to **pull off the brown protective paper** from your acrylic. Attach your leg and acrylic using **1 M3X10MM SOCKET CAP** (part 5), **1 M3 SPLIT WASHER** (part 4), and **1 M3 MOTHERBOARD NUT** (part 1).

## STEP 2 | ATTACHING LEGS TO MIDTRAY

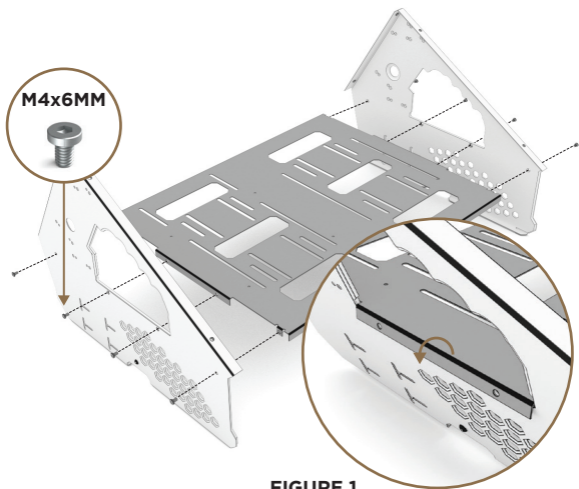
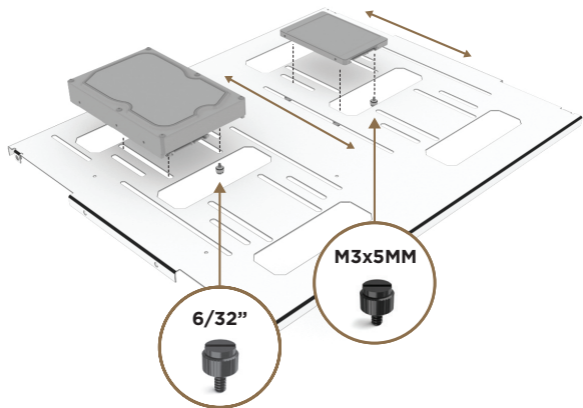

FIGURE 1

Gather the **Midtray** and both **legs**. Attach them using **4 M4X6 lowhead screws (part 2)** on each side. Be sure that the midtray overlaps the leg and that you lean your leg at an angle and then straighten it into the midtray as **Figure 1** shows.

## STEP 3 | HARDDRIVE INSTALL



Install any HDD or SSD on top of the mid tray. These drives can be oriented on either front or back depending on your preference. SSD's use **M3x5 nylon screws (part 9)** and HDD's utilize **6/32" .25 nylon screws (part 7)**.

## STEP 4 | PSU INSTALL

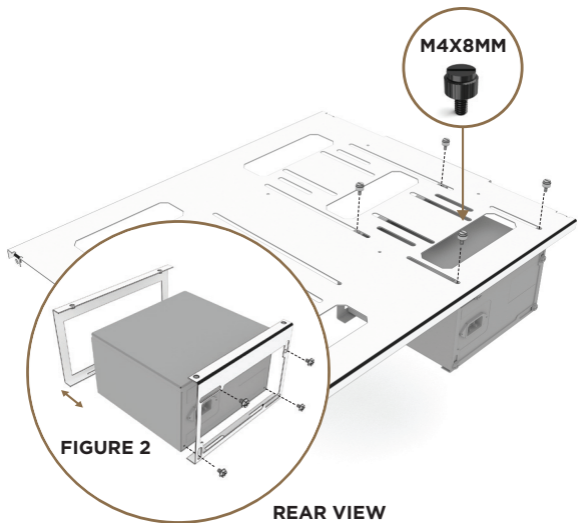

After your drives are installed you can screw in the back of your PSU to the bracket. Then connect it to the location of the midboard tray of your choosing. (Figure 2.2).



## STEP 5 | OPTICAL DRIVE INSTALL

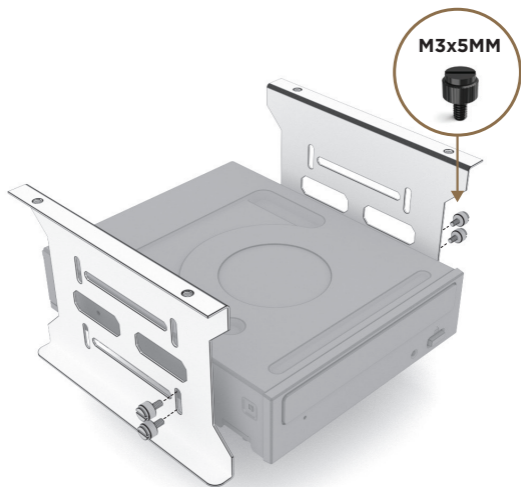

Use **M3x5 nylon screws (part 8)** to install your optical drive. If you're not using one you can disregard this step.

## STEP 6 | MIDTRAY BRACKETS INSTALL

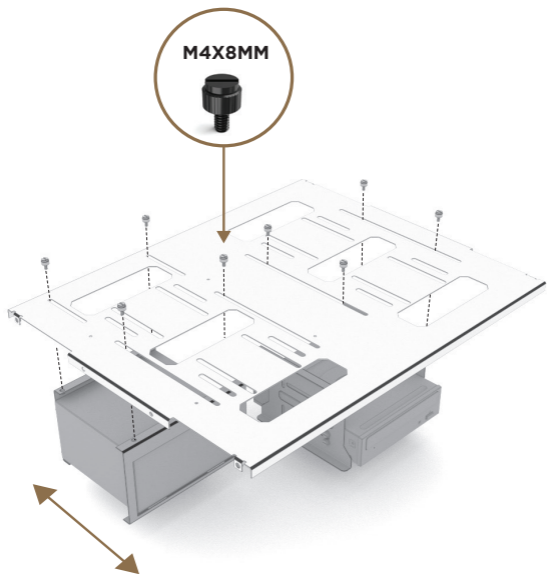

After your drives and/or ODD is installed you can install your brackets onto the midtray using **M4x8 nylon screws (part 8)**.

**Note:** These brackets are modular and can be oriented on both the left and right side and slid forward and backwards.

## STEP 7 | MB & ACYLIC INSTALL

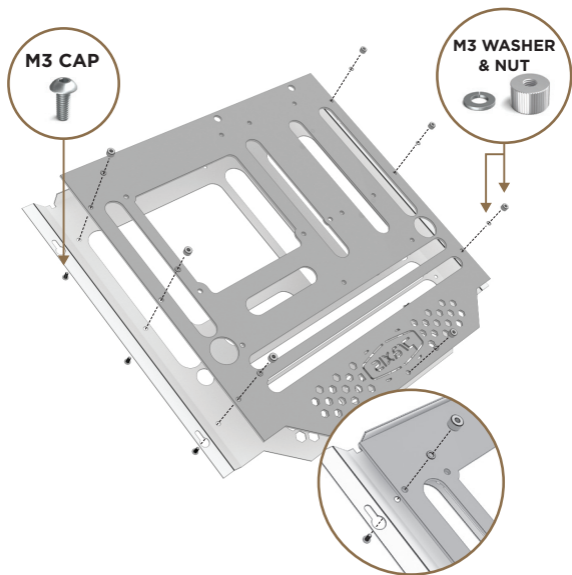

Grab your **motherboard** and **acrylic insert**. Be sure to **pull off the brown protective paper** from your acrylic. Attach your motherboard and acrylic using **7 M3X10MM SOCKET CAP** (part 5), **7 M3 SPLIT WASHER** (part 4), and **7 M3 MOTHERBOARD NUT** (part 1).

## STEP 8 | INSTALLING MB STANDOFFS

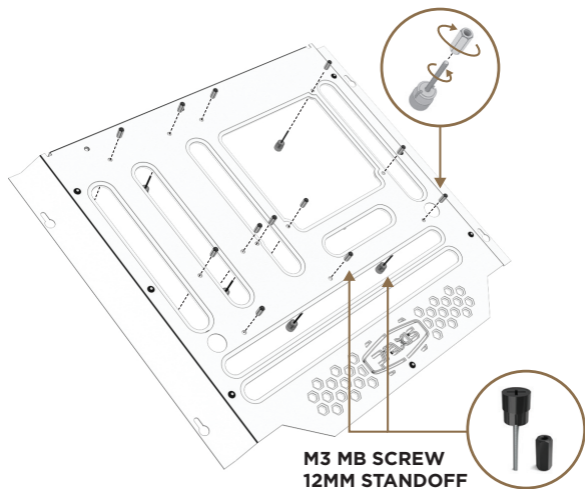

Install your **12mm standoffs (part 3)** and your **M3 motherboard screws (part 10)** to the motherboard tray. Ensure that you're placing them in the correct location according to your motherboard layout. You can also use a drill at it's lowest setting to screw in the standoffs to the motherboard screws.

## STEP 9 | GPU BRACKET INSTALL

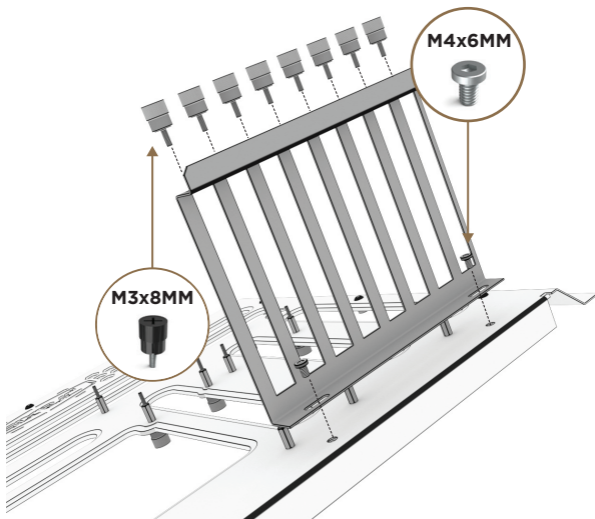

Install the GPU bracket as illustrated above using **2 M4x6 Lowhead screws (part 2)**. You can shift your GPU bracket left and right to align with your GPU. Use **M3x8MM GPU screws (part 6)** to secure your GPU into the bracket.

## STEP 10 | INSTALLING MB TRAY

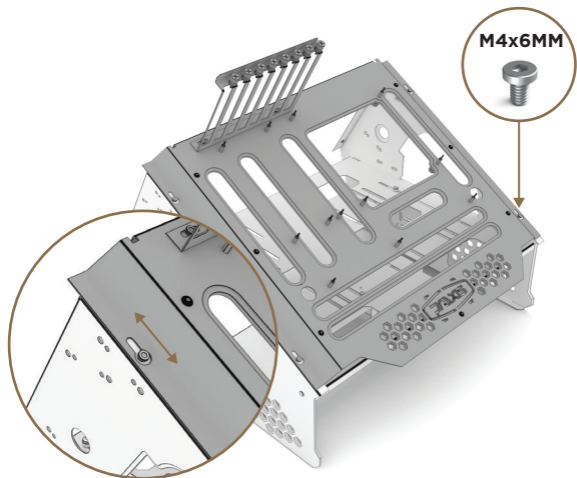

**FIGURE 3**

Screw in **2 M4x6 lowhead screws (part 2)** to each leg (**4 total screws**). Don't completely tighten these (figure 3) as the motherboard tray will slide under the screws as shown in figure 3. After installing the motherboard, you can either tighten the screws down or keep them loose for easy disconnect.

## STEP 11 | INSTALLING MOTHERBOARD

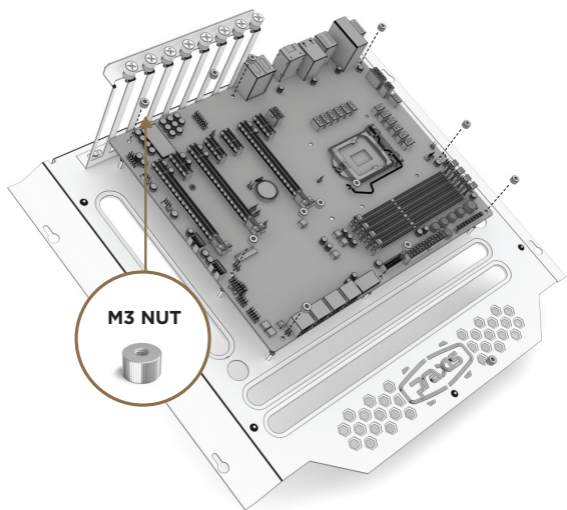

After your standoffs are installed, place your motherboard on the tray and hand tighten the **M3 nuts (part 1)** to properly secure your board. Make sure they are fully tightened ensuring no short will occur.

## STEP 12 | RADIATOR INSTALL

FIGURE 4

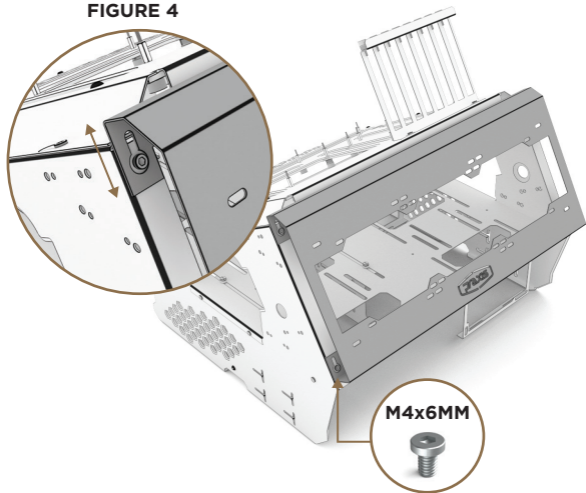

Spin your wetbench to the back and place **2 M4x6 lowhead screws (part 2) on each leg**. Keep these loose so your radiator mount can slide on (figure 4). Once everything is installed you can tighten down the radiator bracket or keep it as is for easy disconnect.



## STEP 12.1 | RADIATOR VARIATIONS



The radiator tray can hold up to a 360mm radiator internally or externally. We recommend utilizing the hardware that came with your radiator for install.

# WIRING VANDAL SWITCH

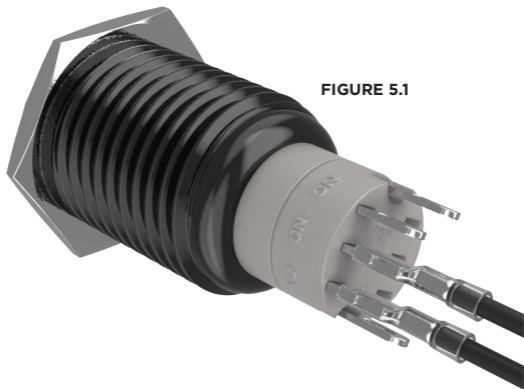
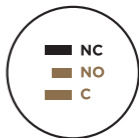

FIGURE 5.1

## Wiring vandal switch for power:

Take the power SW cord and attach the NO and C prong. Then connect the other end to the POWER on the motherboard. Repeat for the RESET button.



POWER & RESET  
FIGURE 5.1

# INSTALLING VANDAL SWITCH

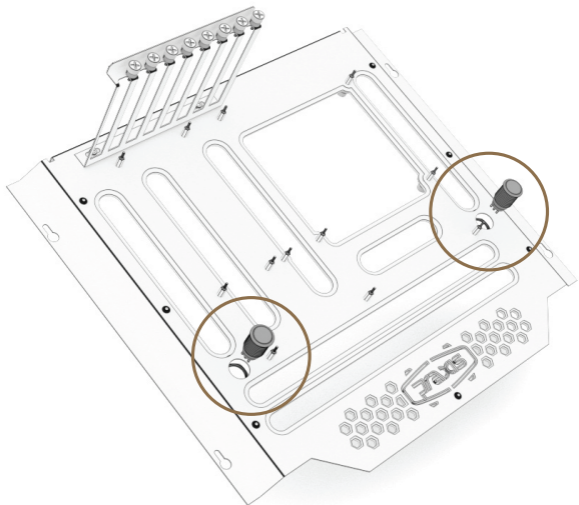

Your 22mm vandal switches can be installed on either the right or left side of the motherboard. Use the supplied hardware to properly secure your vandal switch. We also recommend wiring the switches and testing before installing them to your wetbench.

# WETBENCH

COMPATIBILITY

---

## MOTHERBOARD

MITX, mATX, ATX, eATX

---

## OPTICAL DRIVES

Up to two 5.25" drives, can support dual 5.25" bay reservoir

---

## STORAGE DRIVES

4 HDD or 4 SSD

3 HDD and 1 SSD

2 HDD and 2 SSD

1 HDD and 3 SSD

SSDs up to 2.5" and HDDs up to 3.5" are supported

---

## PSU

ATX PSUs up to 300mm supported

---

## SWITCHES

Up to 2x 22mm Vandal Switches

---

## RADIATORS

Internal | 120mm or 140mm through 360mm or 280mm

External | 120mm or 140mm through 480mm or 420mm

*Thick radiators mount outside. Some air restriction may occur when mounting larger radiators externally.*

---

## RESERVOIRS

PrimoChill CTR II SFF Reservoir

PrimoChill CTR II Low Profile Reservoir