



PrimoChill 240mm CTR Phase II High Flow D5 Enabled Reservoir System w/ Mountable Top Cap

SPECS

PART	DESCRIPTION	DIMENSIONS
1 Reservoir Ring	Quantity x3	2.9" (73.7mm) diameter
2 Reservoir Tube	Variable	Variable
3 Pump Head	Mountable D5	1.85" (47mm)
4 Pump	D5 compatible Pump not included	1.4" (35.8mm)

NOTES:

Screw holes are M4. Reservoir tube can be cut to sized through customization features at primochill.com.

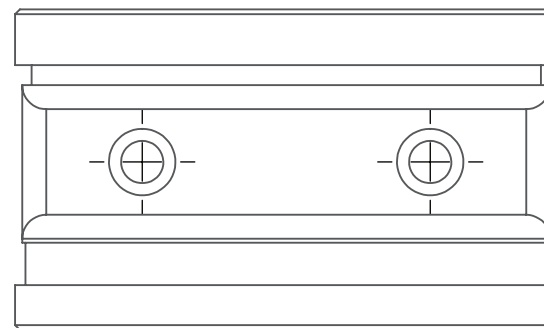

PRINTABLE TEMPLATE
TO SCALE (DONT PRINT TO PAGE)