

PoE Powered VoIP Endpoint Interfaces Analog Paging Systems with SIP and Multicast Paging Sources

The Viking model PA-IP SIP / Multicast Paging Adapter provides an interface between new VoIP phone systems (hardware or hosted/cloud based) and analog paging systems, eliminating the need for an ATA or FXS port. The PA-IP can be used for standard SIP endpoint paging or multicast paging and background music.

The unit easily connects with a single CAT5/6 cable from your PoE switch. An auxiliary trigger input allows an optional hard wired switch or phone system trigger output to enable loud ringing / night bell from after hour incoming calls. Line-level audio output connections are provided for connecting to an external amplifier.



A built-in 4 Watt class D amplifier with speaker output connections are also provided to drive up to 4 analog speakers. A programmable relay output is provided for triggering external amplifiers, etc.

⚠ Installation requires a Network Administrator / IT Technician

Features

- PoE powered (class 2, <6.5 watts)
- Paging prioritization
- Plays audio from multicast
- SIP endpoint or multicast group member
- Supports up to 10 multicast paging groups
- Red "Page/Status" LED indicator
- SIP compliant (see page 2 for list of compatible IP-PBX phone systems)
- Network downloadable firmware
- Autoprovisioning via Viking programming software
- Built-in high efficiency 4 watt class D amplifier
- Relay for activating door locks, strobe lights, external amplifiers, etc.
- SIP/Multicast: SIP page, SIP page and zoned multicast stream, zoned multicast receive
- Support for access code to prevent unwanted SIP calls
- Line-level audio output for connecting to an external amplifier
- Network remote volume control
- Can drive additional external analog speakers for greater coverage

Applications

- Amplified SIP endpoint or multicast IP paging for: schools, hospitals, retail stores, office spaces, etc.
- Provide background music and sound masking
- IP phone system integration with traditional analog amplifier (e.g. single zone voice paging)

Information: 715-386-8861
www.VikingElectronics.com

Specifications

Power: PoE class 2 (<6.5 watts)
Dimensions: 5" x 5.25" x 1.5" (127mm x 133mm x 38mm)
Shipping Weight: 1.0 lbs (0.45 kg)
Operating Temperature: -40°F to 140°F (-40° C to 60° C)
Humidity: 5% to 95% non-condensing
Audio Codecs: G711u, G722 and G711a (SIP only)
Network Compliance: IEEE 802.3 af PoE, SIP 2.0 RFC3261, 100BASE-TX with auto cross over
Sensitivity: 96dB / 1W / 1M S.P. Level
Frequency Response: 55 – 18,000 Hz (+/- 10 dB)
Connections: (1) RJ45 10/100 Base-T, (1) 8 position terminal block

Viking VoIP SIP System Compatibility List

NOTE: Exclusion from this list means only that compatibility has not been verified, it does not mean incompatibility.

For detailed configuration instructions for certain vendors below, see **Configuring Viking VoIP Phone and SIP Servers, DOD# 944**.

Vendor	Infrastructure Class				
	Softswitch	PBX	Proxy	SBC (session border controller)	Service Provider
3COM VCX		X			
3CX		X			
Aastra		X			
Asterisk		X			
Atcom		X			
Avaya Aura Communication Manager	X				
Avaya IP Office		X			
BlueBox		X			
Brekeke		X			
Callcentric					X
Cisco Unified Communications Manager (CUCM)	X	X			
Cisco Unified Communications Manager Express (CUCME)	X	X			
Elastix		X			
Epygi QX200		X			
Freeswitch		X			
Grandstream		X			
Interactive Intelligence	X	X			
iPECS (Ericsson-LG)		X			
iptel.org					X
Kamailio			X	X	
MetaSwitch				X	X
NEC		X			
OfficeSIP		X			
OpenSIPS		X			
Panasonic** (with SIP Extension Card)		X			
Samsung Communications Manager (SCM)	X	X			
ShoreTel*		X			
Siemens Communications Server (SCS)		X			
SIP Express Router (SER)			X	X	
sip.antisip.com					X
Snom PBX		X			
Sonus				X	
Switchvox		X			X
Teksip			X		
Toshiba		X			
VoIP.ms					X

* Note: Not compatible with ShoreTel Ring Group/Hunt Group (unit can be programmed to ring an extension 2 or 3 times then roll to the next number, for a total of 5 numbers).

** Note: Relay operation commands are Not compatible with Panasonic Phone Systems (Panasonic does not transmit DTMF between station ports).

Known Incompatible System or Service Provider: Ring Central (Requires Authorization ID and Proxy address).

Definitions

Client: A computer or device that makes use of a server. As an example, the client might request a particular file from the server.

DHCP: Dynamic Host Configuration Protocol. In this procedure the network server or router takes note of a client's MAC address and assigns an IP address to allow the client to communicate with other devices on the network.

DNS Server: A DNS (Domain Name System) server translates domain names (ie: www.vikingelectronics.com) into an IP address.

Ethernet: Ethernet is the most commonly used LAN technology. An Ethernet Local Area Network typically uses twisted pair wires to achieve transmission speeds up to 1Gbps.

Host: A computer or device connected to a network.

Host Name: A host name is a label assigned to a device connected to a computer network that is used to identify the device in various forms of network communication.

Hosts File: A file stored in a computer that lists host names and their corresponding IP addresses with the purpose of mapping addresses to hosts or vice versa.

Internet: A worldwide system of computer networks running on IP protocol which can be accessed by individual computers or networks.

IP: Internet Protocol is the set of communications conventions that govern the way computers communicate on networks and on the Internet.

IP Address: This is the address that uniquely identifies a host on a network.

LAN: Local Area Network. A LAN is a network connecting computers and other devices within an office or building.

Lease: The amount of time a DHCP server reserves an address it has assigned. If the address isn't used by the host for a period of time, the lease can expire and the address can be assigned to another host.

MAC Address: MAC stands for Media Access Control. A MAC address, also called a hardware address or physical address, is a unique address assigned to a device at the factory. It resides in the device's memory and is used by routers to send network traffic to the correct IP address. You can find the MAC address of your **PA-IP** phone printed on a white label on the bottom side of the chassis.

Router: A device that forwards data from one network to another. In order to send information to the right location, routers look at IP Address, MAC Address and Subnet Mask.

RTP: Real-Time Transport Protocol is an Internet protocol standard that specifies a way for programs to manage the real-time transmission of multimedia data over either unicast or multicast network services.

Server: A computer or device that fulfills requests from a client. This could involve the server sending a particular file requested by the client.

Session Initiation Protocol (SIP): Is a signaling communications protocol, widely used for controlling multimedia communication sessions such as voice and video calls over Internet Protocol (IP) networks. The protocol defines the messages that are sent between endpoints, which govern establishment, termination and other essential elements of a call.

Static IP Address: A static IP Address has been assigned manually and is permanent until it is manually removed. It is not subject to the Lease limitations of a Dynamic IP Address assigned by the DHCP Server. The default static IP Address is: **192.168.154.1**

Subnet: A portion of a network that shares a common address component. On TCP/IP networks, subnets are defined as all devices whose IP addresses have the same prefix. For example, all devices with IP addresses that start with 100.100.100. would be part of the same subnet. Dividing a network into subnets is useful for both security and performance reasons. IP networks are divided using a subnet mask.

TCP/IP: Transmission Control Protocol/Internet Protocol is the suite of communications protocols used to connect hosts on the Internet. TCP/IP uses several protocols, the two main ones being TCP and IP. TCP/IP is built into the UNIX operating system and is used by the Internet, making it the de facto standard for transmitting data over networks.

TISP: Telephone Internet Service Provider

WAN: Wide Area Network. A WAN is a network comprising a large geographical area like a state or country. The largest WAN is the Internet.

Wireless Access Point (AP): A device that allows wireless devices to connect to a wired network using Wi-Fi, or related standards. The AP usually connects to a router (via a wired network) as a standalone device, but it can also be an integral component of the router itself.

Wireless Repeater (Wireless Range Extender): takes an existing signal from a wireless router or access point and rebroadcasts it to create a second network. When two or more hosts have to be connected with one another over the IEEE 802.11 protocol and the distance is too long for a direct connection to be established, a wireless repeater is used to bridge the gap.

Features Overview

Front View

PoE LAN Port 10/100, PoE Class 2 (<6.5 Watts): Connect to your LAN via RJ45 plug and CAT5 or greater twisted pair wire.

Green Unit Status LED

Yellow Network Status LED: Lights steady to indicate power and data link. Blinks to indicate network activity.



Optional Viking Model PA-60 paging amplifier See DOD# 493

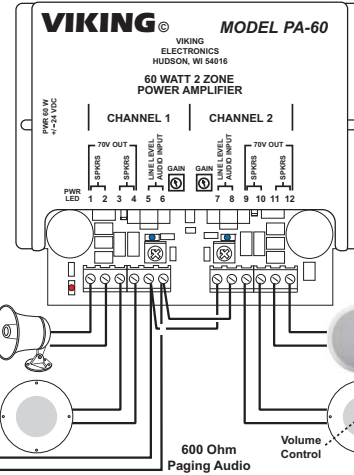

Relay Output Contact (2A@30VDC / 250VAC max)
Connect to trigger input of Amplifier, ect.

Switch Input

Speaker Out

Line Out

Optional Viking Model 40AE analog speakers See DOD# 498

Up to (15) 8 Ohm Speakers (25AE shown, not included)

Up to (15) 8 Ohm Speakers (30AE shown, not included)

Up to (15) 8 Ohm Speakers (40AE shown, not included)

Up to (15) 8 Ohm Speakers (35AE shown, not included)

600 Ohm Paging Audio

Volume Control

Bottom View

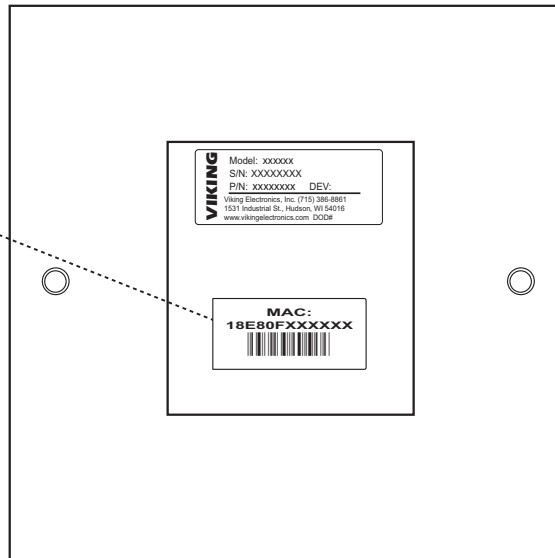

MAC Address Label: The MAC address is a unique 12 digit number used by routers to send network traffic to the correct IP address.

Typical Installation on SIP Based VoIP Phone System

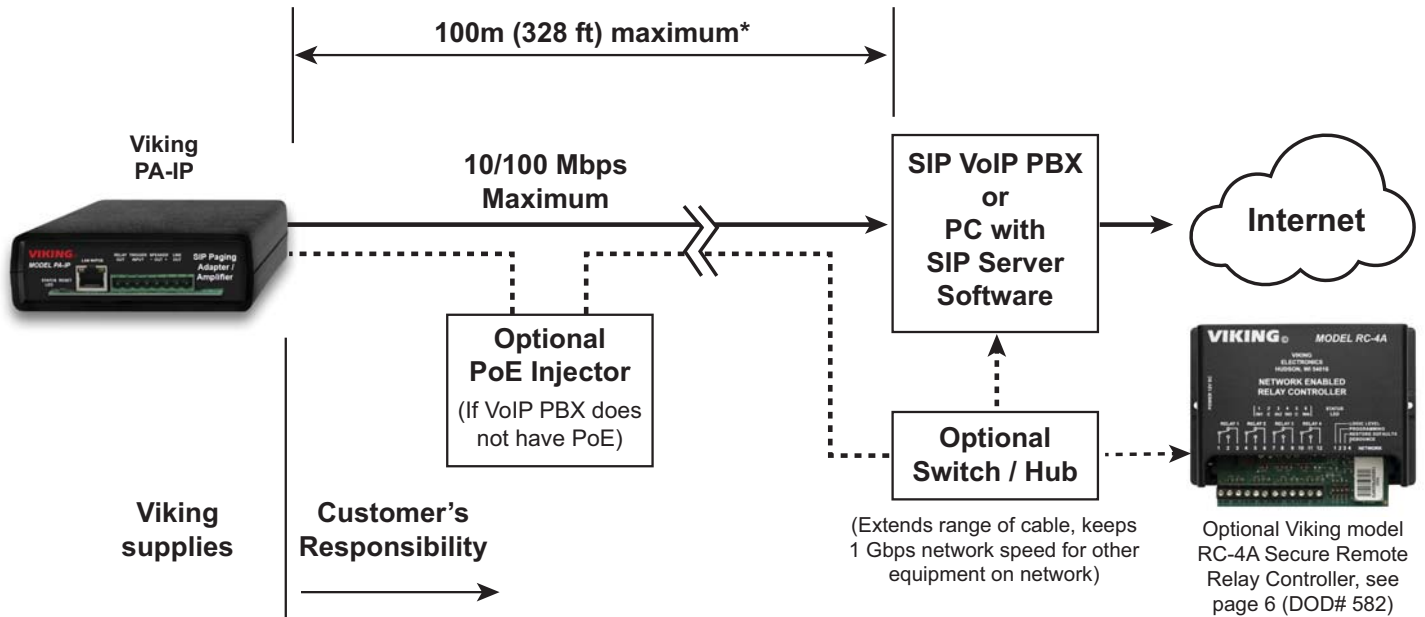

* **Note:** A PoE extender can be used for an additional 100 meters per extender. For longer runs (up to 2 km / 1.2 miles) a ethernet to fiber media converter can be used.

PC Requirements

- **IBM** compatible personal computer with:
 - Windows 2000 (service pack 4 or higher)
 - Windows XP (service pack 2 or higher)
 - Windows Vista (SP2 or newer), 32 or 64 bit versions
 - Windows 7
 - Windows 8
 - Windows 10
- Adobe Acrobat Reader 8 or higher
- **PA-IP** hardware
- Available LAN with PoE (class 2, <6.5 watts)
- Ethernet cable (CAT5 min.)
- 1 MB minimum free hard drive space for installation
- 16MB of free physical RAM

PC Programming

A DVD is included with each **PA-IP**. The DVD contains the application “**Viking IP Programming**” used to program the unit using a PC running Windows 2000, XP, Vista, Windows 7, Windows 8 or Windows 10 (see System Requirements above). The PC must be connected to the same LAN as the **PA-IP**. Install the application on your PC by placing the DVD into your PC’s drive. Click “I Accept” on the bottom of the first screen, then select “Viking IP Programming” and click the “Install” button. Follow the directions on the screen. To start the Viking IP Programming application, click on the Viking IP Programming icon on your desk top. The Main screen will appear, allowing the user to program any **PA-IP** connected to that LAN.

A. Connect/Disconnect

Open the “Viking IP Programming” software on the PC and the start screen shown below will appear. Any Viking IP products that are connected to the network will appear on the list. Simply select the PA-IP on the list and click on the “Connect” button at the bottom or double click the selected unit. If the security code of the selected unit is still set to default (845464), the PC software will not require entering a security code to connect to the phone. PA-IP’s have a default name of “uCMK64_PA-IP”, so if many phones are connected to the same network that all have the default name, MAC addresses must be used to identify each phone.

When finished programming, click on the “Disconnect” button at the bottom. Closing the program will also automatically disconnect the unit.

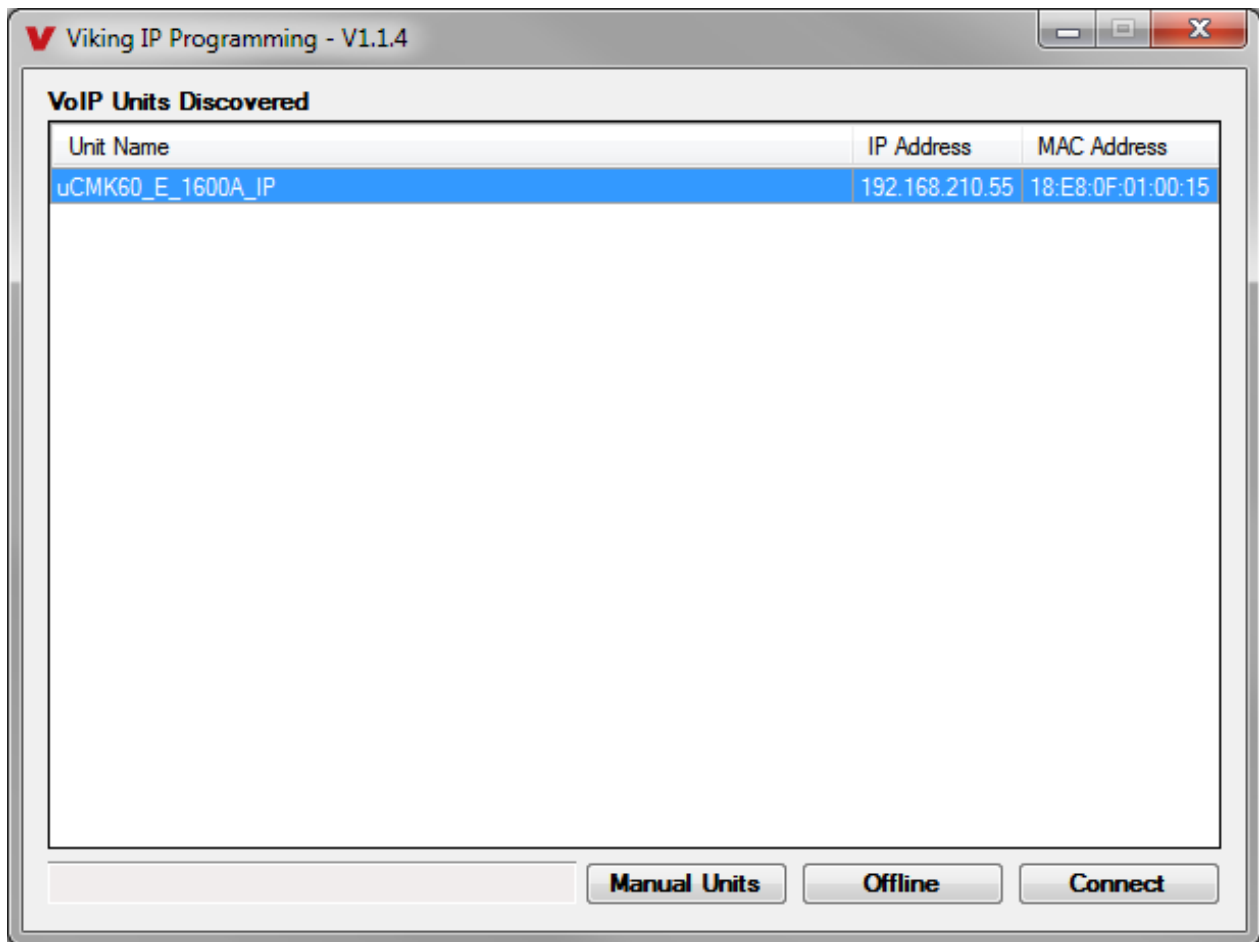

B. Manually Muting SIP/Network Failure Alarm Beeps (3 beeps repeated every 30 seconds)

With the unit connected and powered (Green LED on and Yellow LED off or blinking) it will turn the call LED on and off once per second to indicate a SIP registration failure, failure to receive an echo reply from pinged gateway or Ethernet connection failure. You can manually disable the beeps by pressing and holding the CALL button for 5 seconds or by clicking the “Mute Alarm Until Next Failure” button in the Viking VoIP programming software. The LED will continue to flash allowing you to trouble shoot the failure.

C. Configuring the PA-IP Network Settings

Step 1.	Open the “Viking IP Programming” software on a windows PC that is connected to the same LAN as the PA-IP to be programmed.
Step 2.	The window in the upper left corner of the menu will show you each PA-IP that is connected to that LAN. Select the unit with the same MAC address shown on the label located on the top of the Ethernet connector on the PA-IP .
Step 3.	Click the “Connect” button. If a pop up window appears, enter the unit’s security code (factory set to 845464) then click “OK”.
Step 4.	The program will then read and display the PA-IP ’s IP and programming settings.
Step 5.	Click on the “IP Settings” tab and fill in the three required fields of SIP Server, Username and Password. The SIP provider or the phone system programmer provide the information to put in these fields. The SIP Server field can contain an IP address or a fully qualified domain name. Some examples are shown below. Our phones use port “5060” for traffic by default but another port can be specified by adding a “:” (colon) and the desired port number at the end of the SIP server IP address (for example “192.168.210.61:5070” to specify port “5070”). You can also assign a name for the PA-IP in the Unit Name field. When finished, click on the “Apply” button to send the IP settings to the connected unit. See Examples 1 and 2 of the required fields below:

The screenshot shows the 'Viking IP Programming - V1.1.4' window. At the top, it displays the unit's details: Name: K-1200-IP, MAC: 18:E8:0F:50:03:30, IP: 192.168.210.109. Below this is a navigation bar with tabs: Phone Numbers/ Entry Codes/ Log, Phone Settings, IP Settings (selected), Alarm/ Firmware/ Import/ Export/ Default/ Diagnostics. The main area is divided into several sections:

- Set Unit IP Address via:** DHCP (selected in a dropdown).
- Unit Name:** K-1200-IP
- If DHCP fails:**
 - After 1 minute, use: Last Known IP (dropdown)
 - After 2 Minutes, perform: no action (dropdown)
- Static IP Settings:**
 - Static IP Address: 192.168.210.111
 - Subnet Mask: 255.255.255.0
 - Static Gateway: 192.168.210.18
 - DNS Server IP: 192.168.210.18
- Logging / Time Server Settings:**
 - Syslog Server: 192.168.210.63
 - NTP Server: 2.viking.pool.ntp.org
- SIP Server Settings - Registered:**
 - SIP Server: 192.168.210.63
 - Username: 8000
 - Password: 8000
 - Caller ID: K-12-IP
- Gateway Ping / Registration Time:**
 - Ping Timer (Sec): 60
 - Registration Timer (Min): 60
- Codec Selection and Negotiation Order:**
 - Codecs: G711u, G711a, G722 (dropdown)

A 'Disconnect' button is located at the bottom right of the window.

D. Manually Resetting the Security Code to Enter Programming

Step 1.	Power down the PA-IP by disconnecting the LAN Cable (RJ45 plug).
Step 2.	Press and hold the CALL button, then reconnect the LAN Cable (RJ45 plug).
Step 3.	Continue to hold # key until you hear 2 beeps, (approximately 6 seconds). Then release the button. The “Call” LED will remain off for the first 3 seconds, flash slowly for 3 seconds then fast flash (after 2 beeps), indicating when to release button.
Step 4.	The security code is now reset to 845464 (factory default).
Step 5.	You can now enter programming by following the steps in section A.

E. Manually Resetting All Network Parameters to Factory Default

Step 1.	Power down the PA-IP by disconnecting the LAN Cable (RJ45 plug).
Step 2.	Press and hold the CALL button, then reconnect the LAN Cable (RJ45 plug).
Step 3.	Continue to hold the CALL button until you hear 2 beeps, (approximately 6 seconds). Continue to hold CALL button until you hear 4 more beeps, approximately 6 seconds later, then release the button. The “Call” LED will remain off for the first 3 seconds, flash slowly for 3 seconds (2 beeps), fast flash for 6 seconds (4 beeps), then light steady indicating when to release button.
Step 4.	You can now enter programming by following the steps in section A.

Programming Features Index

DESCRIPTION	Section	Page
Connect/Disconnect	A	8
Security code (factory set to 845464)	1	9
Access Code (1-6 digits, blank = disabled, factory set to 123456)	2	9
Incoming SIP Call Priority over Paging Groups	3	9
Paging Sources	4	9
Internal / External Relay (factory set to Internal)	5	9
Relay Mode (Door Strike, Outbound Call, In/Outbound Call, Doorbell, Alarm Mode, factory set to Door Strike)	6	9
Relay Command (1 or 2 digits, factory set to ** and *2) (Relay Mode must be set to Door Strike)	7	10
Relay Time (0.5 - 99 sec, factory set to 5 sec)	8	10
Relay Latch Commands (Enabled or Disabled, factory set to Enabled)	9	10
Incoming SIP Call Length Time Out (disabled or 1 to 9 min, factory set to 3 min)	10	10
Page Length Time Out (factory set to disabled)	11	10
Inbound Call Mode (Disabled, Auto Answer, Auto Answer-Secure)	12	11
Ring Cadence	13	11
LED Mode	14	11
Unit Name	15	11
Mute Current / Next Alarm	16	11
IP Firmware	17	11
Unit Firmware	18	11
Import/Export	19	11
Default Settings	20	11
Diagnostics (used to check relays)	21	11
Paging Volume		
Ring Volume		

1. Security Code

The security code allows the user/installer to program the **PA-IP**. The factory set security code is 845464. It is recommended that the factory set security code be changed.

Note: The security code must be 6 digits and cannot include a * or a #.

2. Access Code

The Access Code is used for remotely operating the relay (Doorstrike, Mag-Lock, etc) by calling into the unit. This code provides basic security and only allows operation of the relays and not the ability to change any of the programming parameters. Once entered, any of the “Remote Access Operation Commands” can be used. The code can be 1 to 6 digits in length and cannot contain a “*” or “#”. Simply call the **PA-IP** (set to auto-answer/auto-answer secure), the unit will automatically answer the line and output one beep. You then enter the programmed 1 to 6 digit access code, 2 beeps should be heard. You can now enter any “Remote Access Operation Commands” (see page 19).

3. Incoming SIP Call Priority over Paging Groups

Incoming SIP call audio streams can be programmed to have priority over any of the 10 paging groups. Simply check the Incoming calls box then use the drop down menu to select which group/s you want SIP calls to have priority over.

4. Paging Sources

Up to 10 multicast paging groups can be programmed into each **PA-IP**. Each multicast group is defined by a multicast address and port number. Each multicast group is assigned a priority, allowing simultaneously arriving pages to be serviced based on importance. A timeout check box can be selected for each paging group. See Page Length Time Out under Speaker Settings to adjust the timeout from 1 to 255 seconds. Only one timeout time can be programmed for all groups.

Assigning Priority

The **PA-IP** will prioritize simultaneous audio streams according to their priority in the Paging Sources list. Group 0 will have the highest priority while group 9 will have the lowest priority. Group 9 is useful for a low priority stream such as background music. Group 0 is useful for high priority streams such as emergency messages.

The multicast paging groups can also be used for up to ten different paging zones for receiving audio streams. A paging zone can consist of one or many **PA-IP**'s. There is no limit to how many speakers can be in a given paging zone. Each multicast group is defined by a multicast address and port number. Each multicast group is assigned a priority, allowing simultaneously arriving pages to be serviced based on importance.

5. Relay Internal / External

With the relay set to “Internal” the **PA-IP** will activate its on board relay for amplifier signaling, door strike, gate control, etc. The Relay should be set to “External” when using a Viking remote model **RC-4A** relay controller to activate additional relays.

6. Relay Mode

Doorstrike Mode: When programmed for Doorstrike Mode the relay is intended for door strike, maglock or gate control.

Inbound Call Mode: When programmed for Inbound Call Mode the relay will activate continuously for the duration of any inbound or outbound call to or from the Speaker phone. This mode is useful for turning on IR flood lights, for VoIP phones with cameras, etc.

Alarm Mode: When programmed in Alarm Mode the relay will activate continuously while the unit is powered and registered to the SIP server. In the event the unit loses power and/or SIP registration the relay will turn off, which can be used to signal an alarm device.

7. Relay (Activation) Command

The one or two digit code stored in the Relay Activation Command is the touch tone command that the person calling the **PA-IP** must enter on their phone in order to momentarily activate the relay. The code can contain the characters 0 - 9, # or *. The code cannot match a relay latching or toggle command (11, 10, 1#). The code must be entered while the remote phone is communicating with the **PA-IP**. The factory setting is **.

8 Relay Activation Time

The value stored in the Relay Activation Time is the amount of time the relay will be energized after a correct momentary touch tone command is entered. This number can range from 0.5 to 99 seconds. The factory setting is 5 seconds.

9. Relay Latch Commands

When set to “Enabled” (factory default) the Remote Access Operation Commands (*0 to *1) to Un-Latch or Latch the relay are enabled.

When set to “Disabled” the Remote Access Operation Commands (*0 to *1) to Un-Latch or Latch the relay are disabled. Disabling the Latch commands can be useful in applications where you want to eliminate the possibility of inadvertently entering a latch command leaving a gate open/closed, etc.

10. Incoming SIP Call Length Time Out

This feature selects the maximum length of time that incoming SIP calls can be connected. Programmable in increments of 1 minute up to a maximum of 9 minutes or disabled. With the call length disabled, the **PA-IP** must rely on a call ended signal, busy signal, silence, Ring No Answer limit, or return to dial tone to hang-up.

Note: The factory default is 3 minutes.

11. Page Length Time Out

The Paging Length Time Out is factory set to disabled, allowing any length of page or continuous background music. A time out can also be programmed from 1 to 255 seconds in one second increments. A timeout check box can be selected for each paging group. Only one timeout time can be programmed for all multicast paging groups.

12. Inbound Call Mode

The Inbound Call Mode determines how the **PA-IP** handles incoming SIP calls. One option is to generate a loud ring sound. The **PA-IP** can also auto answer the call, to allow SIP paging or remote control of the relay. The “secure” options for auto answer require the callers to dial the access code in order to transmit a page, activate the relay or optional **RC-4A** relays.

Disabled – Inbound SIP calls are not allowed.

Auto Answer – Inbound SIP calls are auto answered on the first ring.

Auto Answer Secure – Inbound SIP calls are auto answered and the caller must dial the access code in order to listen or talk on the unit.

Ring: In the “Ring” mode the unit will not automatically answer an incoming SIP call but will output a loud ring signal in a 2 seconds on, 4 seconds off ring pattern.

13. Ring Cadence

The Ring cadence can be programmed to one of 4 different cadences:

Normal Ring (single ring, 2 sec on 4 sec off)

Double Ring (double ring, 1 sec on .5 sec off 1 sec on 3.5 sec off)

Short-Short-Long (triple ring, .5 sec on .5 sec off .5 sec on .5 sec off 1 sec on 3 sec off)

Short-Long-Short (triple ring, .5 sec on .5 sec off 1 sec on .5 sec off .5 sec on 3 sec off)

14. LED Mode

The “Call” LED on the **PA-IP** can be programmed to one of four different modes: OFF, ON, or paging.

OFF Mode: In this mode the LED will not light during normal operation. It will only light (blink) if it cannot register with the programmed SIP server or while manually resetting all network parameters to factory default.

On Mode: The LED will remain ON in the idle state, turn off while button is pressed, light steady when the call is answered, then turn OFF momentarily when the call is completed.

Paging Mode: The LED will remain OFF in the idle state, light steady when the call is connected, then turn OFF when the call is completed. The LED will also light steady during paging.

15. Unit Name

Up to a 31 character unit name can be assigned to the **PA-IP** being programmed.

16. Mute Current / Next Alarm

A network failure alarm will be indicated by providing 3 beeps every 30 seconds. A network failure indicates the unit is not registered to the SIP server or there is a communication failure with the gateway. The three beeps can be muted by clicking on “Mute Current / Next Alarm”.

17. IP Firmware

If new **PA-IP** firmware is available, after opening the programming software a pop window will come up asking you if you would like to update firmware. An alternative method of updating can be done by clicking the IP firmware “Update” button. You can then browse to the folder that contains the PIP file for updating the unit’s IP firmware. This method is typically only used when Viking Technical Support has sent you updated IP firmware

18. Unit Firmware

If new **PA-IP** firmware is available, after opening the programming software a pop up window will ask if you would like to update firmware. Another way to update is accomplished by clicking the phone firmware “Update” button. You can then browse to the folder that contains the HEX file for updating the unit’s firmware. This method is typically only used when Viking Technical Support has sent you updated firmware.

19. Import/Export

The Import/Export feature is useful for backing up all the **PA-IP**’s programming or for importing programming when installing multiple units with a majority of the same programming.

20. Default Settings

Clicking on the “Default Settings” button in programming will reset all of the Programming Features back to their factory default settings. **Note:** *This command will not change or reset your IP settings.*

20. Diagnostics

The Diagnostics section in the Viking IP Programming can be used to test the functionality of the relay.

Operation

Remote Access Operation Commands

The following commands can be entered after answering an inbound SIP call from the unit. After the unit auto answers the SIP call, two beeps will be heard. If the access code has been disabled, you can now enter the Remote Access Operation Commands below. If an Access code has been programmed, enter the Access code digits. With the correct code entered, two beeps will be heard and you can now enter the Remote Access Operation Commands below.

Feature	Tone Tone Command	Description
Activate Relay	** or ____	Momentarily activate relay (1 or 2 digits, factory set to **).
Un-Latch Relay	*0	Un-latch* (deactivate) the relay.
Latch Relay	*1	Latch* (continuously activate) the relay.
Disconnect	#	Disconnects or forces the emergency phone to hang up.

* **Note:** Latching commands must be enabled (*6) in programming.

Troubleshooting

If the unit cannot register with the programmed SIP server, the “Call” LED will blink on and off every two seconds, and three error beeps will be heard every 30 seconds until communication is restored. This alerts a potential user of a problem with the device that will prevent an emergency phone call from being made.

You may silence the error beeps, per instance, by pressing and holding the CALL button for 5 seconds or by clicking the “Mute Alarm Until Next Failure” button in the Viking VoIP Programming Software (see section on page ?). The error beeps automatically re-enable once the unit is registered, to alert of any new problems that arise.

Related Products

Viking IP Speakers

The Viking model **40TB-IP** Talk-Back Ceiling/Wall Speaker enables two-way conversations via SIP and also allows for standard paging and background music via multicast. The Talk-Back Speaker easily connects with a single CAT5/6 cable from your PoE switch. Its shallow depth allows the speaker to be conveniently mounted in a standard 2” x 4” stud wall or ceiling.

An auxiliary switch input allows a hard wired wall button to initiate a SIP call. Alternately, an optional wireless Bluetooth remote call button can be used (Viking model **BTR-3**, sold separately). A momentary button press will initiate a standard call, and holding the button for 3 or more seconds will initiate an emergency call. The remote can also be used to adjust the speaker volume. The LED on the **40TB-IP** can be programmed to blink when there is call activity.

The integrated microphone enables talk-back and also monitors room noise to automatically increase speaker volume when necessary. Line-level audio output connections are provided for connecting to an external amplifier. Speaker output connections are also provided to directly drive additional analog speakers.

A programmable relay output is provided for activating door locks, strobe lights, external amplifiers, etc. For more info, see **DOD# 502**.



40TB-IP



40-IP

The Viking model **40-IP** Ceiling/Wall Speaker enables SIP endpoint paging and also allows for standard paging and background music via multicast. The speaker easily connects with a single CAT5/6 cable from your PoE switch. Its shallow depth allows the speaker to be conveniently mounted in a standard 2” x 4” stud wall or ceiling.

Line-level audio output connections are provided for connecting to an external amplifier. Speaker output connections are also provided to directly drive additional analog speakers. The LED on the **40-IP** can be programmed to light during paging. For more info, see **DOD# 503**.

Viking Analog Speakers

The **25AE**, **30AE**, **35AE**, and **40AE** paging speakers provide additional economical paging coverage to existing Viking paging units (**40-IP**, **PA-2A**, **PA-15**, **PA-30**, **PA-60**, **HF-3W**, **M2W**) or to any system with an 8 ohm output.

In outdoor, factory or warehouse environments, **25AE** paging horns are the best method of producing understandable sound. In these environments the directional design allows the installer to focus the sound cone down aisles and toward work areas.

In office and restaurant environments, it is best to distribute sound more evenly. Ceiling mounted **30AE**, **35AE**, or **40AE** speakers in close proximity offer the best distribution and are cost effective. The **35AE** speakers include a volume control.



30AE

35AE

40AE

25AE

300AE

30AE/35AE Ceiling Speakers

- Metal white grill for flush mounting in office ceilings
- Mounting hardware included
- Excellent frequency response
- The **35AE** includes a volume control

40AE Ceiling Speakers

- Attractive with a modern look
- Flush mounts into a 9.5" to 10" diameter hole
- Integral mounting system
- Excellent sound quality

25AE Paging Horn

- Adjustable base for easy mounting and directional adjustment
- Compact design for discreet mounting

300AE Paging Horn

- 30 Watt 8 ohm / 70V Paging Horn

Control Relay Contacts Across a Local Area Network

The **RC-4A** Network Enabled Relay Controller provides networked control of four relays via an easy-to-use web interface. The same interface can be used to check the status of four contact closure inputs. Relays can be toggled on or off, or user-programmed timed closures can be activated.

The **RC-4A** can be configured to work as a remote relay for Viking VoIP series entry phones, controlling door strikes and gates when a remote relay is required for security reasons. It can also be programmed to send an email or text message in response to a change in one or more of the sensor inputs. Two **RC-4A**'s can be set up so that activity on a sensor input of one unit will automatically send a message across the network to activate one of the relays on the other unit. Two levels of user access permit selected users to have full operational and programming rights while others have operational control but not programming capability. For more info, see **DOD# 585**



Tile Bridge for Ceiling Speakers



The **SA-TBA** is a tile bridge designed to mount 8 inch loud speaker and bridges both 2 ft x 2 ft and 2 ft x 4 ft ceiling tiles. It is compatible with the Viking models **SA-1S**, **30AE**, **35AE**, and **40AE** speakers. The **SA-TBA** tile bridge is constructed of 24 gauge cold rolled steel with an electro galvanized rust-resistant finish.

Related Products

Add Paging, Loud Ringing and Background Music to Centrex, PABX, IP, or Key Systems

The **PA-15** interfaces with virtually any telephone system to provide 15 watts of paging power - enough to drive fifteen 8-ohm paging horns or speakers. This small and light weight chassis design is possible by utilizing new amplifier technology that is 300% less inefficient than old designs competitors use. High efficiency means much less heat disipation, smaller size, higher reliability, and lower cost.

The **PA-15** provides 36V talk battery for interfacing with an **FXO** or unused analog line input/trunk port. With the flip of a switch, the unit can connect to a **FXS** or PABX/Centrex station ring trip port or connect to a 600 ohm paging port. When interfacing with systems that do not provide a paging contact closure, the built-in voice activation (**VOX**) is in control.

After paging, the **PA-15** auto disconnects on CPC, busy signal, silence, or default disconnect timer (helps prevent accidental paging system lock-up if phone is hung-up incorrectly). The unit will generate adjustable loud ringing from an independent ringing analog **FXS**/PABX/Centrex station or from a dry contact closure. The **PA-15** can provide background music (muted during page) if connected to an external music source.



Add Paging and Loud Ringing with Background Music to Any Phone System

The **PA-30** can directly drive up to thirty (30) 8 ohm paging speakers or fifty (50) 70 volt or 25 volt paging speakers. This small and light weight chassis design is possible by utilizing new amplifier technology that is 300% less inefficient than old designs competitors use. High efficiency means much less heat disipation, smaller size, higher reliability, and lower cost.

The **PA-30** provides loud ringing and paging to electronic key systems, 1A2 Key systems, PABX's as well as No-KSU phones and multi-line phones.

Paging is accomplished by connecting the **PA-30** to a paging port or unused telephone line input (trunk port) of nearly any phone system.

The **PA-30** will also generate adjustable loud ringing from a ringing analog line or from a dry contact closure. Either a loud electronic warble, or one of three other soft chime sounds may be selected. An external "night transfer" switch can be added to turn loud ringing on or off in night bell applications.

The **PA-30** eliminates the installation of multiple bells, relays and paging cards. The unit comes complete with a power supply, and integrated 30 watt amplifier.



60 Watt Compact Two Zone Amplifier to Drive up to 60 Paging Speakers

The **PA-60** can directly drive up to sixty (60) 8 ohm paging speakers or one hundred (100) 70 volt or 25 volt paging speakers. Both channels can be fed the same input so the **PA-60** can be used as a single large amplifier, or each channel can be fed different inputs so the **PA-60** can be used as a two zone amplifier.

This small and lightweight chassis design is possible by utilizing new amplifier technology that is 300% less inefficient than old designs competitors use. High efficiency means much less heat disipation, smaller size, higher reliability, and lower cost.

Since each input has its own gain adjustment, one zone can be turned up louder for warehouse paging horn speakers, and the other zone can be turned down for office ceiling speakers. Two zones can also be helpful for installations in which one group of speakers is connected to a source that provides background music using the Viking **PI-1A** Paging Interface unit, and the other zone provides only paging.

The Viking models **CTG-1** or **CTG-2** can be used to add clock controlled tones with paging to both zones, or one zone can have just paging and be free of the time scheduled alert tones. The same can be done with the Viking model **MTG-10** in which one zone can have just paging, and the other zone can have paging plus the 10 different siren, warble, and chime tones that the **MTG-10** can provide.

One or two **PA-60**'s can be added to the Viking model **ZPI-4** four zone paging interface to provide either 60 watts or 120 watts of total paging power in four zones. The **PA-60** can also be used to add additional paging power to other Viking paging products such as the **PA-2A**, **PA-15**, and **PA-30**.

The **PA-60**'s inputs are transformer coupled so they are floating and isolated. Because of this they can be connected to any line level audio signal, or by turning down the input gain control to unity gain, can be connected directly to the output of another amplifier. This allows the **PA-60** to be connected directly to an existing paging system speaker wire run to extend the run, with up to 60 more speakers.



Warranty

IF YOU HAVE A PROBLEM WITH A VIKING PRODUCT, CONTACT: VIKING TECHNICAL SUPPORT AT (715) 386-8666

Our Technical Support Department is available for assistance Monday through Friday 8:00am to 5:00pm central time. So that we can give you better service, before you call please:

1. Know the model number, the serial number and what software version you have (see serial label).
2. Have your Product Manual in front of you.
3. It is best if you are on site.

RETURNING PRODUCT FOR REPAIR

The following procedure is for equipment that needs repair:

1. Customer must contact Viking's Technical Support Department at 715-386-8666 to obtain a Return Authorization (RA) number. The customer MUST have a complete description of the problem, with all pertinent information regarding the defect, such as options set, conditions, symptoms, methods to duplicate problem, frequency of failure, etc.
2. Packing: Return equipment in original box or in proper packing so that damage will not occur while in transit. Static sensitive equipment such as a circuit board should be in an anti-static bag, sandwiched between foam and individually boxed. All equipment should be wrapped to avoid packing material lodging in or sticking to the equipment. Include ALL parts of the equipment. C.O.D. or freight collect shipments cannot be accepted. Ship cartons prepaid to: **Viking Electronics, 1531 Industrial Street, Hudson, WI 54016**
3. Return shipping address: Be sure to include your return shipping address inside the box. We cannot ship to a PO Box.
4. RA number on carton: In large printing, write the R.A. number on the outside of each carton being returned.

RETURNING PRODUCT FOR EXCHANGE

The following procedure is for equipment that has failed out-of-box (within 10 days of purchase):

1. Customer must contact Viking's Technical Support at 715-386-8666 to determine possible causes for the problem. The customer MUST be able to step through recommended tests for diagnosis.
2. If the Technical Support Product Specialist determines that the equipment is defective based on the customer's input and troubleshooting, a Return Authorization (R.A.) number will be issued. This number is valid for fourteen (14) calendar days from the date of issue.
3. After obtaining the R.A. number, return the approved equipment to your distributor, referencing the R.A. number. Your distributor will then replace the Viking product using the same R.A. number.
4. **The distributor will NOT exchange this product without first obtaining the R.A. number from you. If you haven't followed the steps listed in 1, 2 and 3, be aware that you will have to pay a restocking charge.**

TWO YEAR LIMITED WARRANTY

Viking warrants its products to be free from defects in the workmanship or materials, under normal use and service, for a period of two years from the date of purchase from any authorized Viking distributor. If at any time during the warranty period, the product is deemed defective or malfunctions, return the product to Viking Electronics, Inc., 1531 Industrial Street, Hudson, WI., 54016. Customer must contact Viking's Technical Support Department at 715-386-8666 to obtain a Return Authorization (R.A.) number.

This warranty does not cover any damage to the product due to lightning, over voltage, under voltage, accident, misuse, abuse, negligence or any damage caused by use of the product by the purchaser or others. This warranty does not cover non-EWP products that have been exposed to wet or corrosive environments. This warranty does not cover stainless steel surfaces that have not been properly maintained.

NO OTHER WARRANTIES. VIKING MAKES NO WARRANTIES RELATING TO ITS PRODUCTS OTHER THAN AS DESCRIBED ABOVE AND DISCLAIMS ANY EXPRESS OR IMPLIED WARRANTIES OR MERCHANTABILITY OR FITNESS FOR ANY PARTICULAR PURPOSE.

EXCLUSION OF CONSEQUENTIAL DAMAGES. VIKING SHALL NOT, UNDER ANY CIRCUMSTANCES, BE LIABLE TO PURCHASER, OR ANY OTHER PARTY, FOR CONSEQUENTIAL, INCIDENTAL, SPECIAL OR EXEMPLARY DAMAGES ARISING OUT OF OR RELATED TO THE SALE OR USE OF THE PRODUCT SOLD HEREUNDER.

EXCLUSIVE REMEDY AND LIMITATION OF LIABILITY. WHETHER IN AN ACTION BASED ON CONTRACT, TORT (INCLUDING NEGLIGENCE OR STRICT LIABILITY) OR ANY OTHER LEGAL THEORY, ANY LIABILITY OF VIKING SHALL BE LIMITED TO REPAIR OR REPLACEMENT OF THE PRODUCT, OR AT VIKING'S OPTION, REFUND OF THE PURCHASE PRICE AS THE EXCLUSIVE REMEDY AND ANY LIABILITY OF VIKING SHALL BE SO LIMITED.

IT IS EXPRESSLY UNDERSTOOD AND AGREED THAT EACH AND EVERY PROVISION OF THIS AGREEMENT WHICH PROVIDES FOR DISCLAIMER OF WARRANTIES, EXCLUSION OF CONSEQUENTIAL DAMAGES, AND EXCLUSIVE REMEDY AND LIMITATION OF LIABILITY, ARE SEVERABLE FROM ANY OTHER PROVISION AND EACH PROVISION IS A SEPARABLE AND INDEPENDENT ELEMENT OF RISK ALLOCATION AND IS INTENDED TO BE ENFORCED AS SUCH.

If trouble is experienced with the **PA-IP** phone, for repair or warranty information, please contact:

Viking Electronics, Inc., 1531 Industrial Street, Hudson, WI 54016 (715) 386-8666

WHEN PROGRAMMING EMERGENCY NUMBERS AND (OR) MAKING TEST CALLS TO EMERGENCY NUMBERS:

Remain on the line and briefly explain to the dispatcher the reason for the call. Perform such tests in off-peak hours, such as early morning or late evenings.

PART 15 LIMITATIONS

This equipment has been tested and found to comply with the limits for a Class A digital device, pursuant to Part 15 of the FCC Rules. These limits are designed to provide reasonable protection against harmful interference when the equipment is operated in a commercial environment. This equipment generates, uses, and can radiate radio frequency energy and, if not installed and used in accordance with the instruction manual, may cause harmful interference to radio communications. Operation of this equipment in a residential area is likely to cause harmful interference in which case the user will be required to correct the interference at his own expense.

Product Support: (715) 386-8666

Due to the dynamic nature of the product design, the information contained in this document is subject to change without notice. Viking Electronics, and its affiliates and/or subsidiaries assume no responsibility for errors and omissions contained in this information. Revisions of this document or new editions of it may be issued to incorporate such changes.