



INSTALLATION GUIDE

ENDORSED BY



AWLA
Annual National Lock and Hardware Show

**Congratulations on
purchasing Oscillot[®],
the revolutionary cat
containment system.
This guide contains
everything you need
to know for easy
DIY installation
to your fence.**

BEFORE COMMENCING INSTALLATION	4
SAFETY INSTRUCTIONS	8
PRODUCT SAFETY	8
HAND TOOL SAFETY	9
THINGS YOU'LL NEED	10
TOOLS	10
PARTS	11
PRELIMINARY STEPS IF INSTALLING WITH BRACKETS	12
INSTALLATION	14
CUTTING PADDLES DOWN TO SIZE	28
ADDITIONAL CAT-PROOFING FOR A TIMBER FENCE	37
ELIMINATING PLATFORMS & LADDERS	38
INTRODUCING YOUR CAT TO OSCILLOT®	42

BEFORE COMMENCING INSTALLATION

Oscillot® is designed to prevent cats from scaling fences with a minimum height of 1.80 metres when installed correctly according to installation instructions on a suitable fence type and yard set up.

The recommendation of 1.80 metres is made as it is the height at which the system has been extensively tested and has proven to be safely and reliably effective. Installing Oscillot® on lower fence heights may reduce the effectiveness of the system.

To ensure the effectiveness of Oscillot®, check that your existing fence secures the full perimeter of your yard:

- ✓ Block-off any gaps.
- ✓ Make sure that your cat cannot dig or crawl under the fence.
- ✓ Keep the fence clear of any objects that your cat may use to scale the fence, e.g. garbage bins, building materials and barbeques.
- ✓ Remove any shrubs and bushes located close to the fence.
- ✓ Install tree guards around the trunk of any trees located close to the fence.
- ✓ Remove any tree branches overhanging the fence.

The most important point to remember when installing Oscillot® is that your cat needs to be jumping from the ground to the top of the fence in a single motion with no help on the way up in the form of ladders or platforms. Ladders and platforms include objects next to the fence such as garden beds trees, trellis, sheds and etc. It can also include horizontal beams on your fence (if your cat is particularly agile).

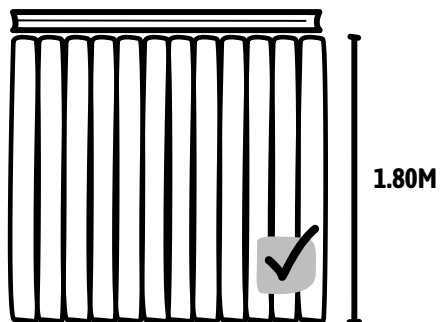
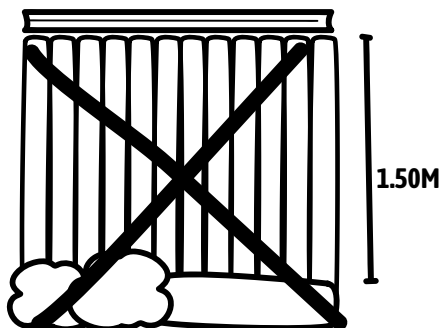

BEFORE COMMENCING INSTALLATION (CONT.)

For more than 90% of installations, installing Oscillot® alone is adequate and will result in effective cat-proofing of the fence to keep your cat safe at home. For some fence setups, in particular timber fences with the posts and rails on the inside of the fence, an extra cat-proofing measure in addition to installing Oscillot® may in some instances be required. This is due to the 'climbability' of some timber fences.

You can read more about additional cat-proofing for timber fences on page 37.

Most installations only take a matter of hours and require only a few tools. If you don't have the tools or time to install, check our website for a list of Handyman Services. If you have a local Handyman, they will likely be able to do the installation for you. Get them to check our Installation Guide and call us if they have any questions.

We're happy to offer more specific advice about your fence and yard setup if required. See the back page of this guide for ways to get in touch with us.



CHECK FENCE TOPS

Fence tops made from non-solid materials may need a fixed metal capping or other reinforcing before Oscillot® can be installed. All mounting surfaces must be in good repair and able to support the Oscillot® components.



CHECK GATES

Gates may require re-hinging to allow the gate to open in the other direction where Oscillot® paddles will be on the leading edge of tops of gates.



CREATE AN UNBROKEN BARRIER

Ensure the system is installed in a way that creates an unbroken barrier around the perimeter of the area. Only correct installation of Oscillot® combined with other necessary escape proofing measures can result in effective containment.











CATS ONLY

Oscillot® must only be used to contain cats. It is not suitable to contain other animals, such as dogs, because excess weight may bend the paddles out of shape. It is the responsibility of every pet owner to comply with the rules and regulations that govern pet ownership. Check with your local council for desexing, microchipping, registration and confinement by-laws governing your area.

Commonly, Council approval is not required when adding attachments to a fence as long as the overall height of the fence remains below 200 centimetres. However, before installing Oscillot® it is recommended that you check with your Local Government Authority to determine if a permit or approval is required. Also check if approval is required from neighbours with whom you share the fence and/or the property owner or strata manager. It is recommended that permission is obtained in writing where possible.

SAFETY INSTRUCTIONS

PRODUCT SAFETY

-  Oscillot® contains small components that may be a choking hazard. Keep out of reach of children.
-  Do not allow persons to hang from or place excess weight on Oscillot® once installed.
-  Do not allow children under the age of 16 to install Oscillot®. The tools required for installation can cause serious injury or death.
-  Installation of Oscillot® requires the use of power tools. Please read the user manual associated with the relevant tools and wear appropriate personal protection, such as safety glasses and ear protection.
-  Keep cutting tools sharp and clean. Properly maintained cutting tools with sharp cutting edges are less likely to bind and easier to control.
-  Use clamps or another practical way to secure and support the paddles to a stable platform when cutting. Holding the work by your hand or against the body leaves it unstable and may lead to loss of control.
-  Ensure the mini screw is installed to secure the cap to the post, to avoid the system coming apart when a cat places weight on the paddles.
-  Always use ladders, and not chairs or stools, and be sure to use the ladder in its intended way.
-  The paddle ends can be sharp, be cautious when handling.

HAND TOOL SAFETY

SCREWDRIVER

Never use a screwdriver as a chisel, as it might shatter and become a hazard.

Always make sure the handle and shaft do not have any cracks and are in good condition before using a screwdriver.

Never use a screwdriver as some sort of pry bar.

Always take the time to find the right size and type of screwdriver for the job, as this will make your work go by much quicker and also ensure the job gets done the safest way possible.

HAMMER

Never use a hammer which has a loose or cracked handle, as the head may fly off and become a hazard.

Ensure that the hammer is both the proper type and size for the job you are performing, as this will make your work go by much quicker and also ensure the job gets done the safest way possible.

Never use a hammer with a chipped, cracked, or broken claw.

When using a hammer, keep your motions short and compact, and try to avoid longer swings of the hammer. This will not only cause you to be more accurate with what you strike with the hammer, this will decrease the chance of you hitting something or somebody by accident at the top of the hammer stroke.

SAW

Ensure that the saw's teeth are sufficiently sharp, as a dull tool is much more dangerous than a sharp tool.

Always be careful to cut in a direction that puts yourself and others out of harm whenever possible.

Always use a vice or other means to secure your work, as this will make it both easier and safer to make a cut with a saw.

Select the proper saw for your particular job, as this will make your work go by much quicker and also ensure the job gets done the safest way possible.

Never use a saw with chipped teeth or cracked blades or cracked handles.

THINGS YOU'LL NEED

TOOLS

You will need the following tools to install the Oscillot® system:

- Drill
- 150mm Phillips driving bit
- 2.5mm drill bit
- Tape measure
- Marking pen
- Mitre box
- Electric drop-down mitre saw with an aluminium cutting blade, or a fine tooth aluminium saw
- Hammer

PARTS



PART #1
Post

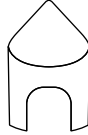

PART #2
Cap

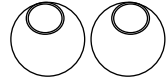

PART #3
Ball

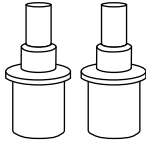

PART #4
Axle Pin

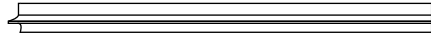

PART #5
Paddle

Timber Screws
8GA x 1"

Metal Screws

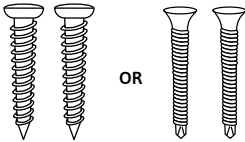

PART #6
Fixing Screw



PART #7
Mini Screw (6GA x 1/4")

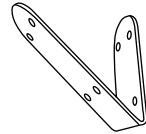

PART #8
Bracket



PART #9
Bracket Screw

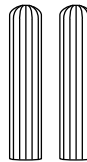

PART #10
Masonry Plug* (32mm)

*only included if 'masonry installation' selected on website purchase.

PRELIMINARY STEPS IF INSTALLING WITH BRACKETS

If you have a timber paling fence or a horizontal rail within 400mm of the top of your fence, follow the steps in this section. Otherwise, continue with Installation on page 14.

DETERMINE ANGLE

The bracket can be attached to the fence at different angles but should be attached within 5cm of the top of the fence. Determine the most effective angle for your type of fence.

Brackets can be used to angle and extend the paddles further from the fence. We generally recommend using brackets on timber paling fences and on any fences with a horizontal rail within 400mm of the top of your fence.

CALCULATING BRACKETS NEEDED

You will need an equal number of brackets and posts. The number of dual knuckle post kits required will determine the number of brackets required.

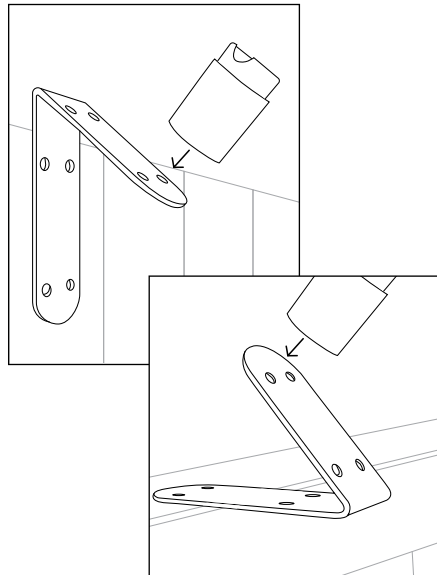

STEP 1

Determine the most effective angle for your type of fence. Place the post (1) onto the bracket (8).

The bracketed numbers in the steps refer to the part number listed in Parts on page 11.

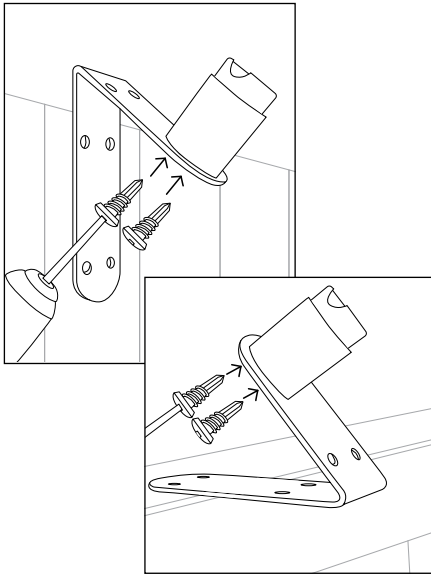

STEP 2

With a 150mm Phillips driver bit attached to your drill, screw 2 bracket screws (9) from the underside of the bracket into the base of the post.

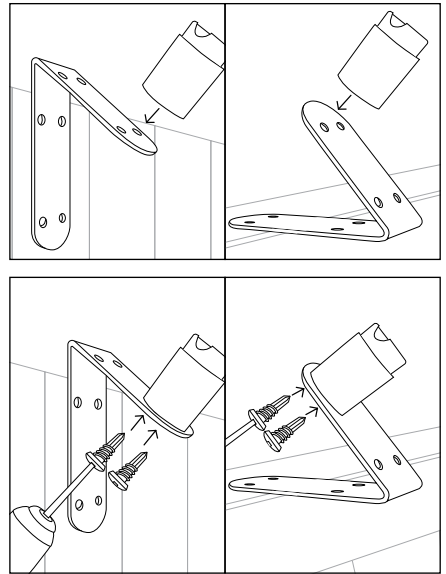

STEP 3

Repeat steps 1 to 3 until all posts have been attached to the brackets.

Once you're done,
continue from Installation
on page 14.

INSTALLATION

IMPORTANT!
There must be no gap
between the start of the
fence and the first post.

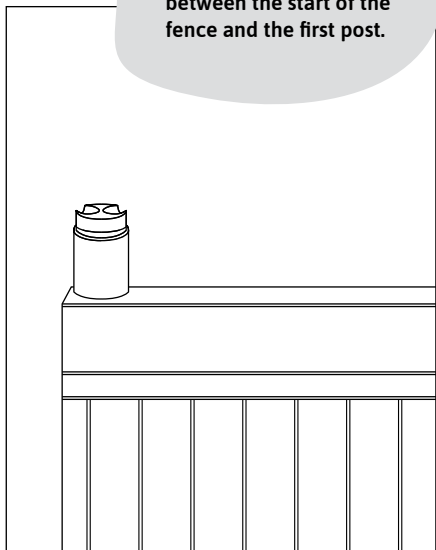

STEP 1

Place the first post at the start of the fence run, ensuring that the screw holes are parallel with the fence.

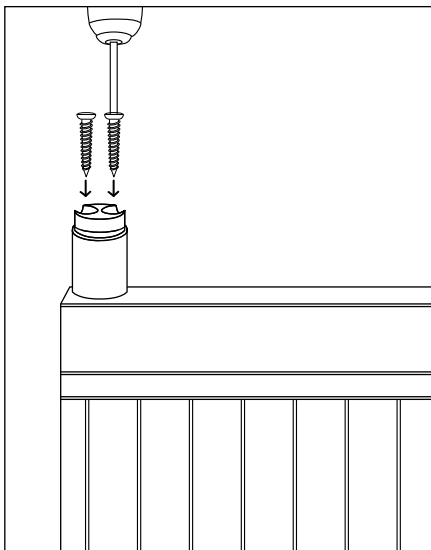

STEP 2

Using your drill with the 150mm Phillips driving bit attached, screw the 2x fixing screws (6) through the post (1) and into the fence.

The bracketed numbers in the steps refer to the part number listed in Parts on page 11.

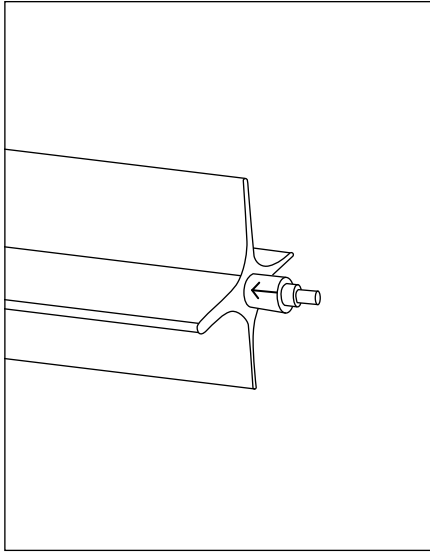

STEP 3

Push an axle pin (4) into one end of the paddle (5).

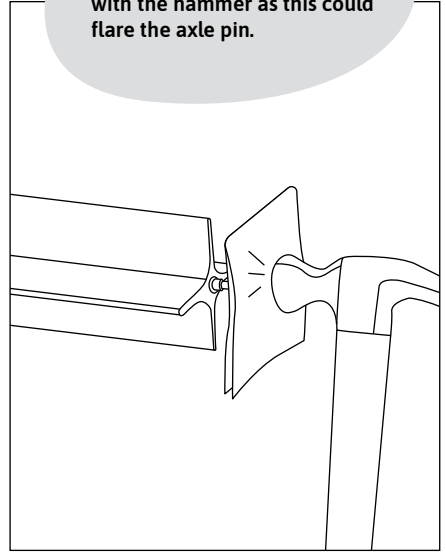

IMPORTANT!

Do not hit the axle pin directly with the hammer as this could flare the axle pin.

STEP 4

Place a cloth onto the axle pin and gently tap the axle pin through the cloth with a hammer until the axle pin is fully inserted into the end of the paddle.

INSTALLATION (CONT.)

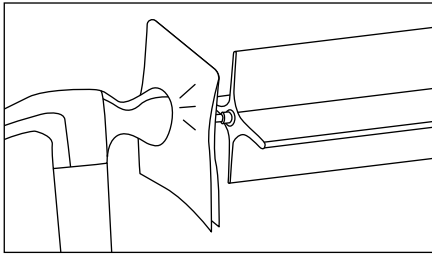
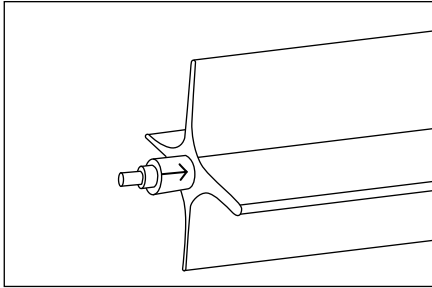

STEP 5

Repeat steps 3 and 4 for the other end of the paddle.

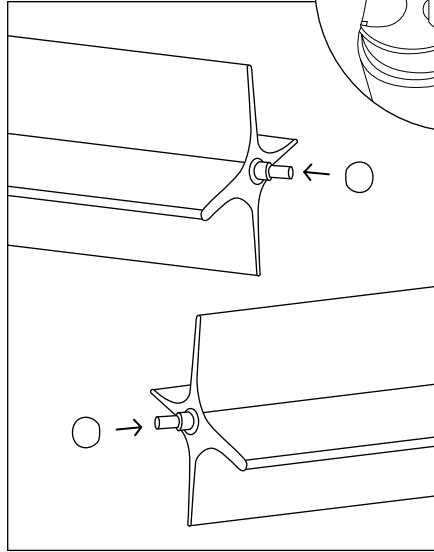

STEP 6

Place a ball* on each axle pin, leaving a 1mm gap between the ball and the axle pin, to allow the paddle to spin freely.

* The hole in the centre of the ball is less narrow at one end to help prevent the ball from slipping off the pin, so test the ball by placing a pin in one side and then in the other side, one side will spin a lot more freely than the other, leave the pin in the side of the ball that spins more freely.

The bracketed numbers in the steps refer to the part number listed in Parts on page 11.

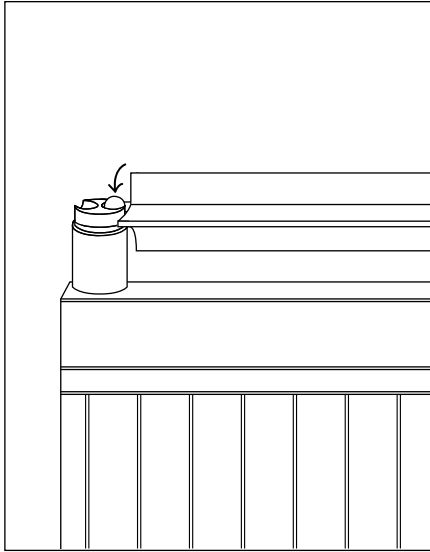

STEP 7

Place one end of the paddle in the knuckle indent on the secured post.

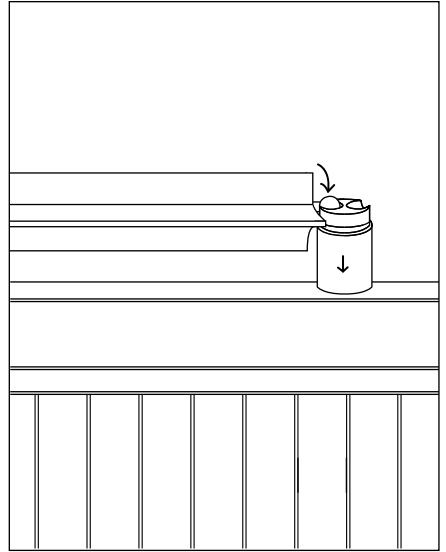

STEP 8

Place another post on the fence at the other end of the paddle and rest the paddle in the knuckle indent.

INSTALLATION (CONT.)

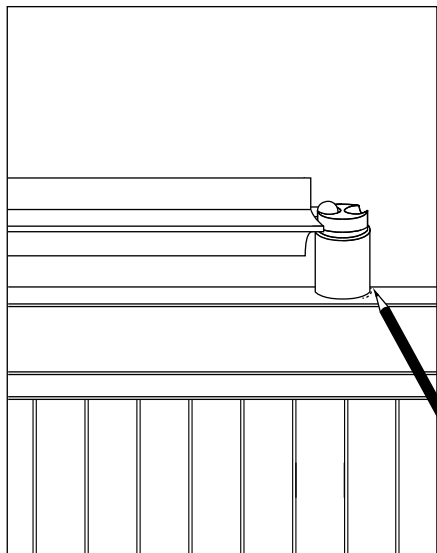

STEP 9

Using your marking pen, mark the position for the newly positioned post on the fence.

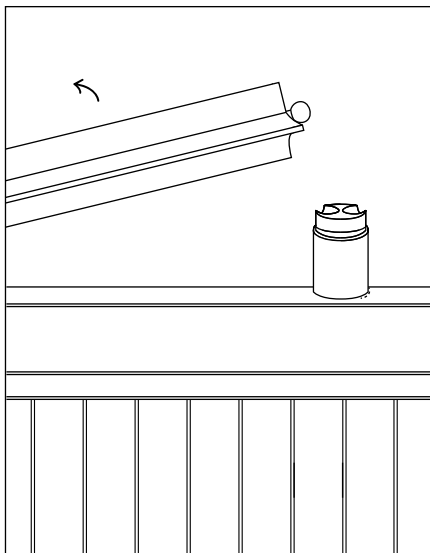

STEP 10

Remove the paddle.

The bracketed numbers in the steps refer to the part number listed in Parts on page 11.

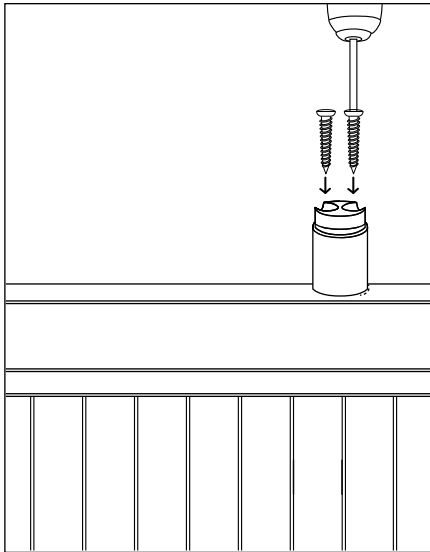

STEP 11

Ensuring that the post is in-line with the mark, use your drill to screw the 2x fixing screws through the post into the fence.

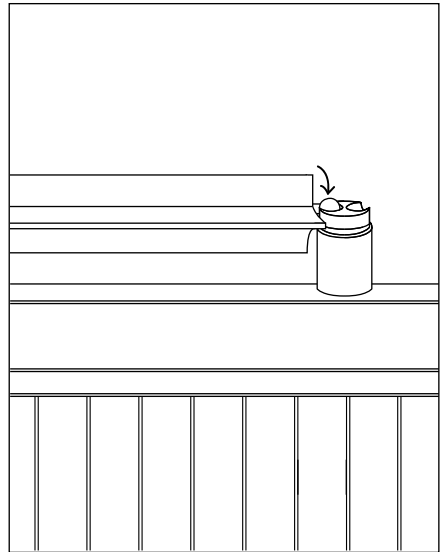

STEP 12

Place the paddle back into position.

INSTALLATION (CONT.)

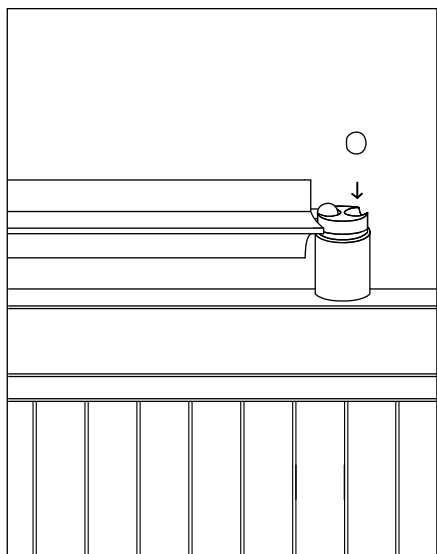

STEP 13

Place a ball in the second knuckle indent of the last post that you installed.

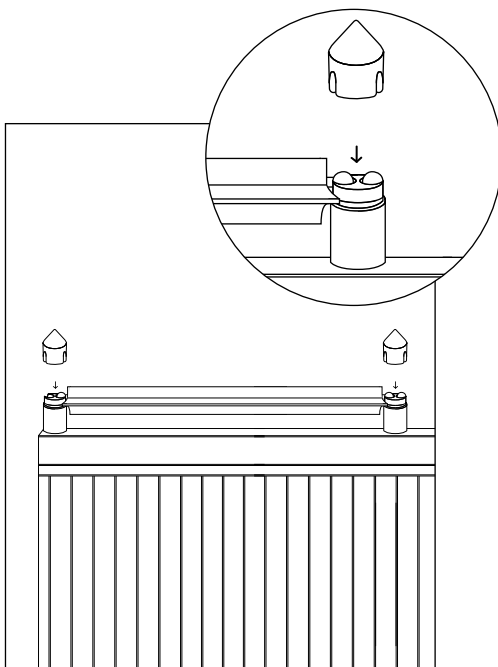

STEP 14

Place a cap (2) on each post.

The bracketed numbers in the steps refer to the part number listed in Parts on page 11.

IMPORTANT!

Leave a 1mm gap between the ball and the axle pin to ensure that the paddle spins freely.

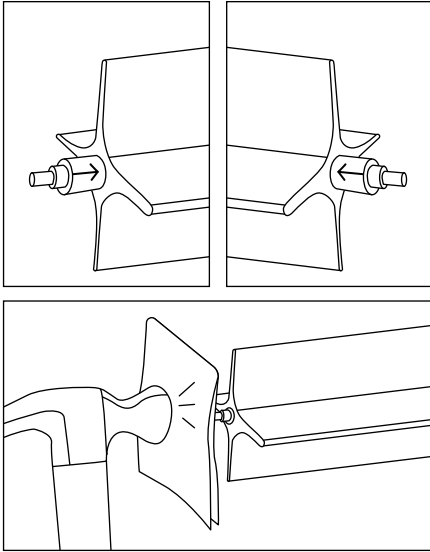

STEP 15

Prepare the next paddle by inserting axle pins (4) into both ends of the paddle (5).

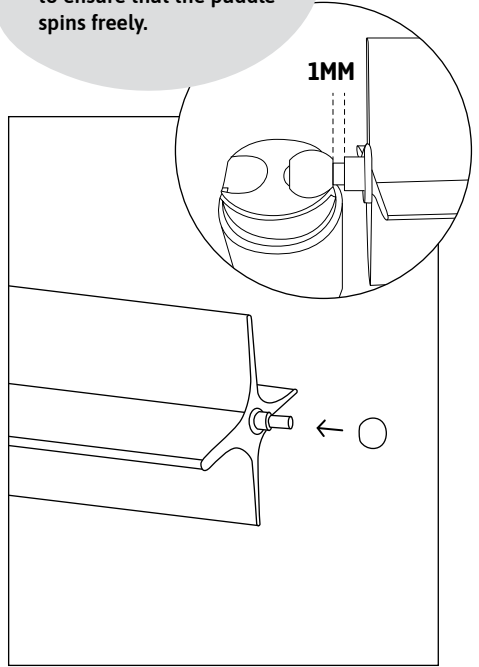

STEP 16

Place a ball on one end of the paddle.

INSTALLATION (CONT.)

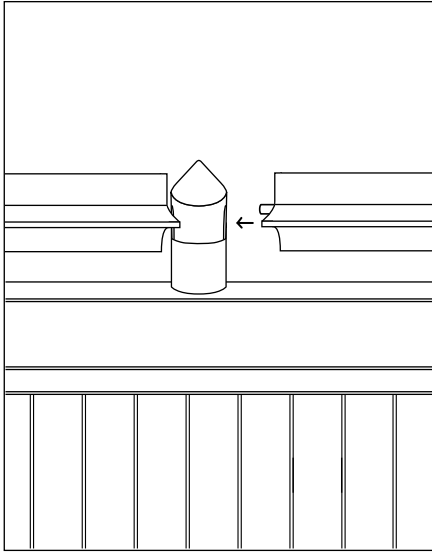

STEP 17

Slip the axle pin of the other end of the paddle into the ball within the knuckle indent of the last post that you installed.

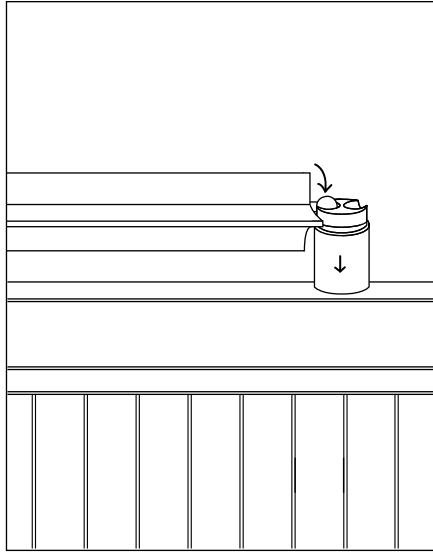

STEP 18

Place another post on the fence at the other end of the paddle and rest the paddle in the knuckle indent.

The bracketed numbers in the steps refer to the part number listed in Parts on page 11.

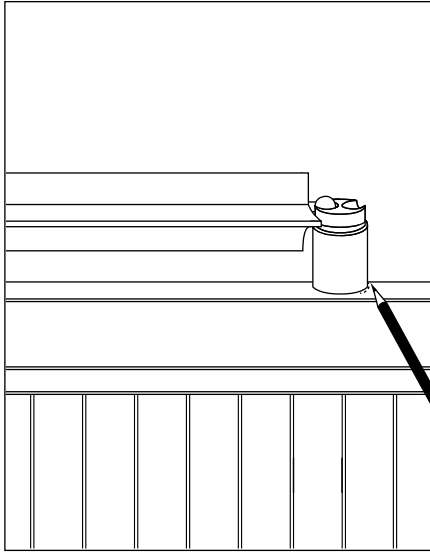

STEP 19

Using your marking pen, mark the position of the post on the fence.

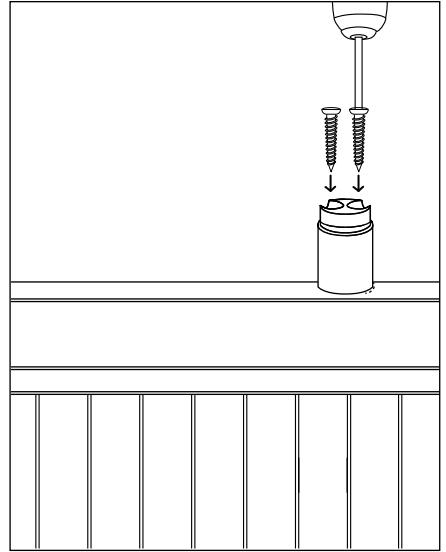

STEP 20

Ensuring that the post is in-line with the mark, use your drill to screw the 2x fixing screws through the post into the fence.

INSTALLATION (CONT.)

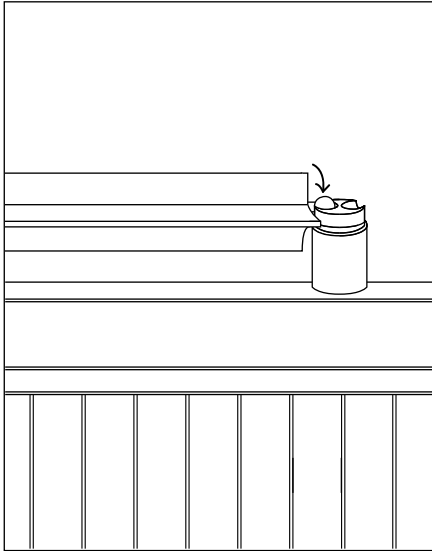

STEP 21

Place the paddle back into position on the post you've just fixed. Place a cap on the post (the opposite end should already be inserted into the other post).

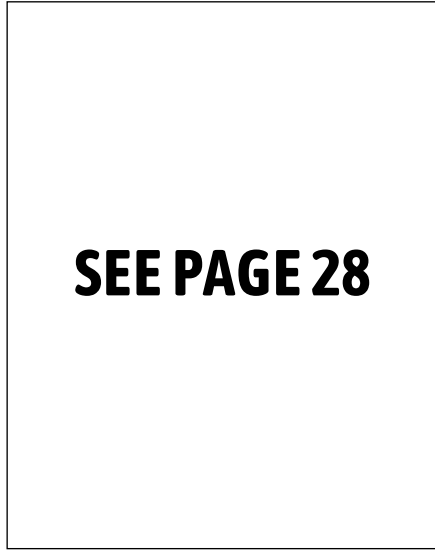

STEP 22

If the final paddle in a fence run needs to be cut to a smaller size, see 'Cutting paddles down to size' on page 28.

The bracketed numbers in the steps refer to the part number listed in Parts on page 11.

IMPORTANT!

The first post for each fence run must abutt each other to ensure that there is no gap between the spinning paddles.

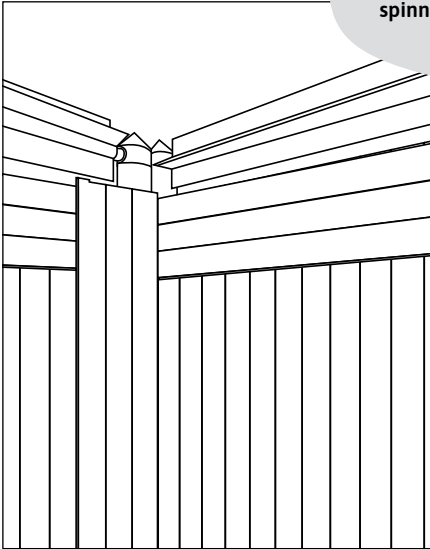

STEP 1–21

STEP 23

Ensure paddles overlap sufficiently in corners to form an unbroken barrier as best as possible.

STEP 24

Complete the remaining fence runs by following Steps 1 to 21.

INSTALLATION (CONT.)

Once the entire installation is complete, you'll need to secure all of the caps onto the posts one-by-one. This will prevent the caps from becoming dislodged when weight or force is applied to the paddles.

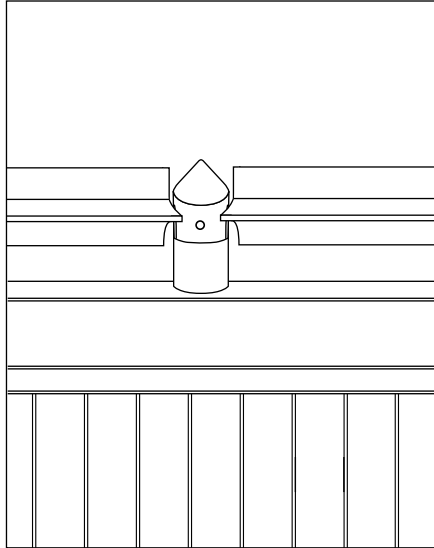

STEP 25

With the 2.5mm bit attached to your drill, drill a 7-10mm pilot hole into the side of each cap.

The bracketed numbers in the steps refer to the part number listed in Parts on page 11.

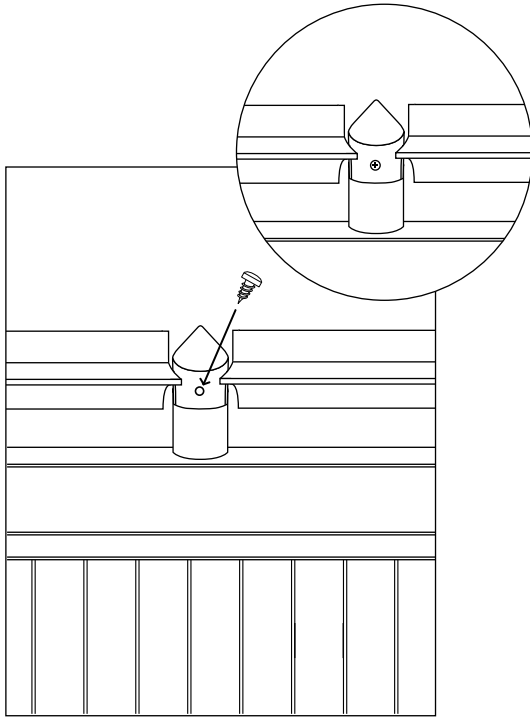

STEP 26

With the 150mm Phillips driver bit attached to your drill, drill a mini screw (7) into each cap.

CUTTING PADDLES DOWN TO SIZE

The last paddle in each fence run will most likely need to be cut down to size. Any offcuts can be used on smaller sections, such as between a house and gate.

IMPORTANT!

There must be no gap between the final post and the end of the fence.

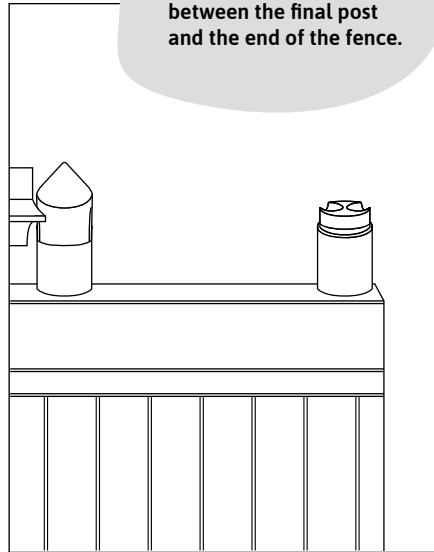

STEP 1

Place the final post at the end of the fence run, ensuring that the screw holes are parallel with the fence.

The bracketed numbers in the steps refer to the part number listed in Parts on page 11.

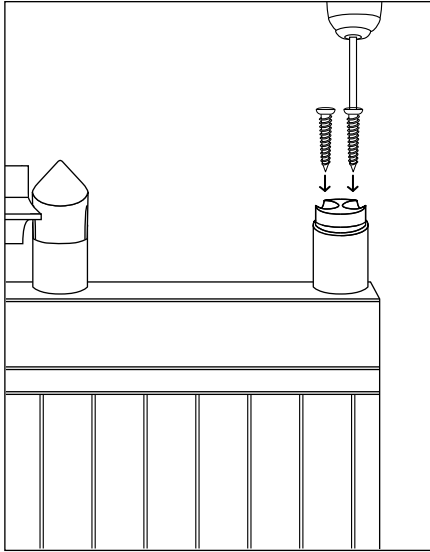

STEP 2

Screw the 2x fixing screws (6) through the post and into the fence.

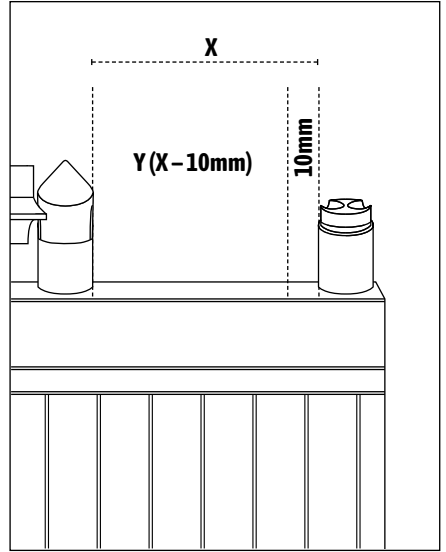

STEP 3

Measure the final gap between the last two posts and subtract 10mm.

CUTTING PADDLES DOWN TO SIZE (CONT.)

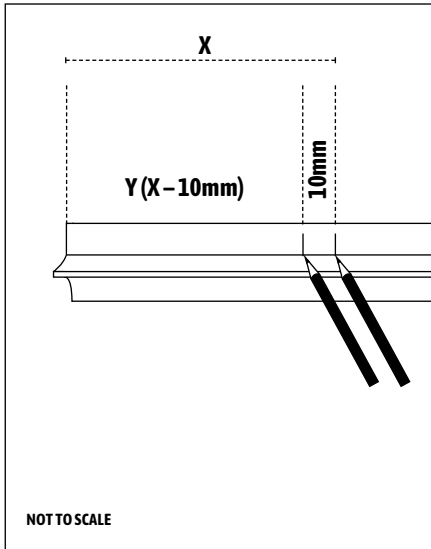

STEP 4

Using your marking pen, mark the cut position on the paddle (5) at the correct length.

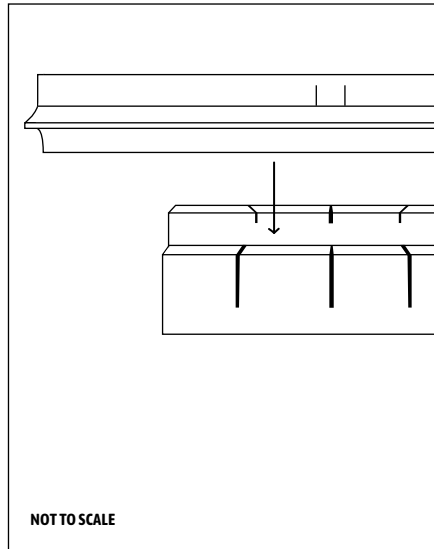

STEP 5

Place the paddle in a mitre box to ensure a straight cut.

The bracketed numbers in the steps refer to the part number listed in Parts on page 11.

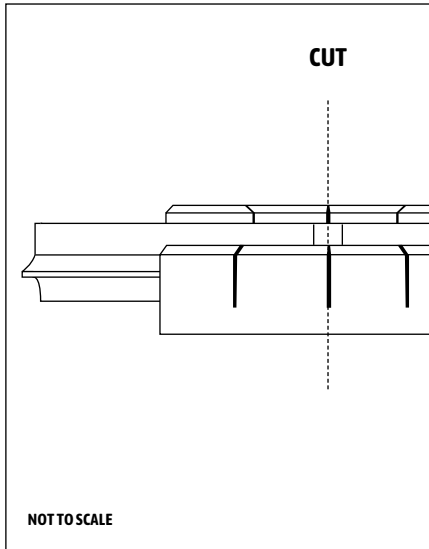

STEP 6

Cut the paddle using either:

- a. an electric drop-down mitre saw with an aluminium cutting blade or;
- b. a sharp fine-toothed aluminium saw.

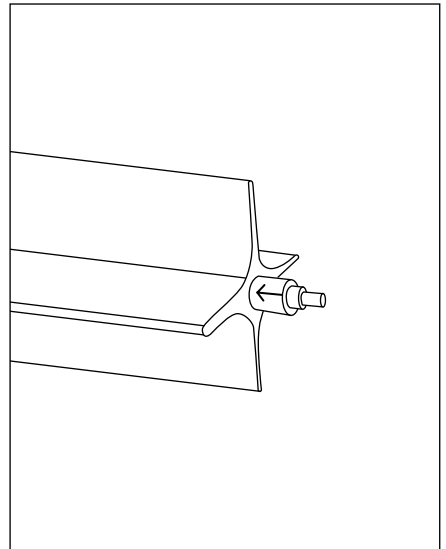

STEP 7

Push an axle pin (4) into one end of the paddle (5).

CUTTING PADDLES DOWN TO SIZE (CONT.)

IMPORTANT!

Do not hit the axle pin with the hammer. This could flare the axle pin, which would result in the ball becoming jammed on the pin. If this does occur, carefully file back the pin until it rotates freely within the ball.

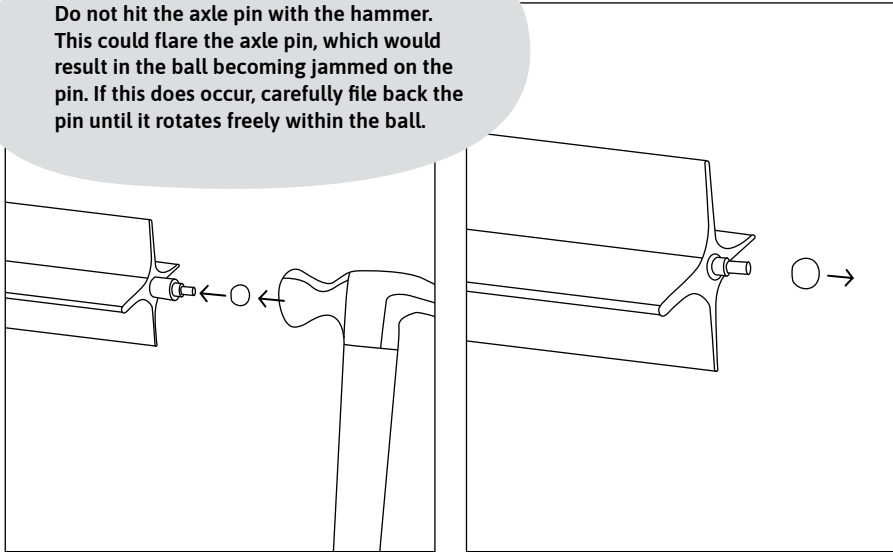

STEP 8

Place a ball onto the axle pin and gently tap the ball with a hammer until the axle pin is fully inserted into the end of the paddle.

STEP 9

Remove the ball.

* The hole in the centre of the ball is less narrow at one end to help prevent the ball from slipping off the pin, so test the ball by placing a pin in one side and then in the other side, one side will spin a lot more freely than the other, leave the pin in the side of the ball that spins more freely.

The bracketed numbers in the steps refer to the part number listed in Parts on page 11.

IMPORTANT!

Leave a 1mm gap between the ball and the axle pin to ensure that the paddle spins freely.

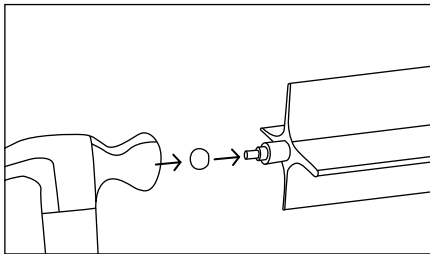
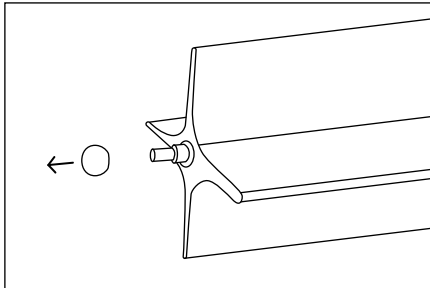

STEP 10

Repeat steps 7 to 9 for the other end of the paddle.

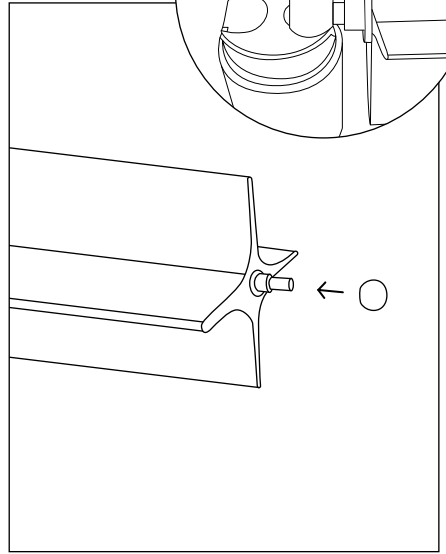

STEP 11

Place a ball* on one end of the paddle.

CUTTING PADDLES DOWN TO SIZE (CONT.)

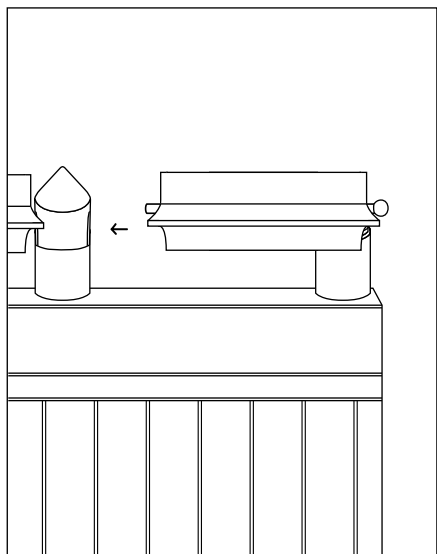

STEP 12

Slip the axle pin of the other end of the paddle into the ball within the knuckle indent of the second-last post.

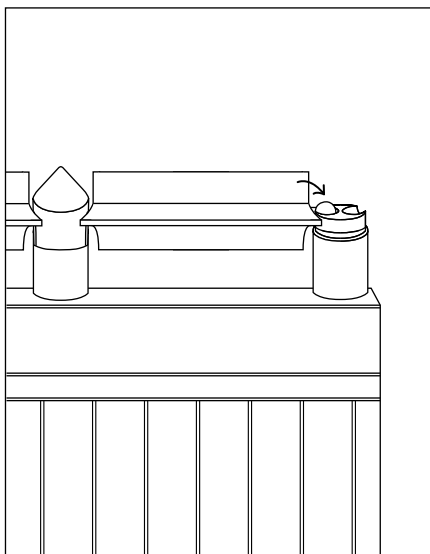

STEP 13

Place the paddle in the knuckle indent of the last post.

The bracketed numbers in the steps refer to the part number listed in Parts on page 11.

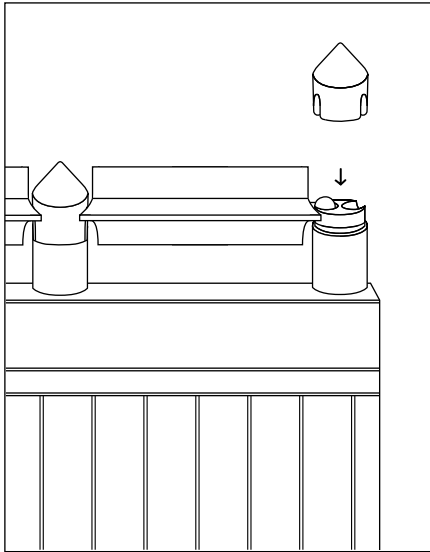

STEP 14

Place a cap on the last post.

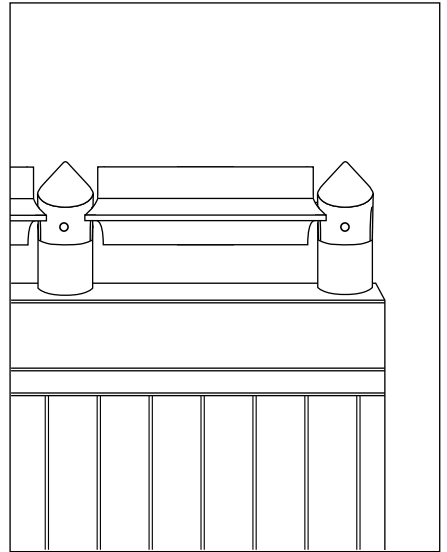

STEP 15

With the 2.5mm bit attached to your drill, drill a 7-10mm pilot hole into the side of each cap.

CUTTING PADDLES DOWN TO SIZE (CONT.)

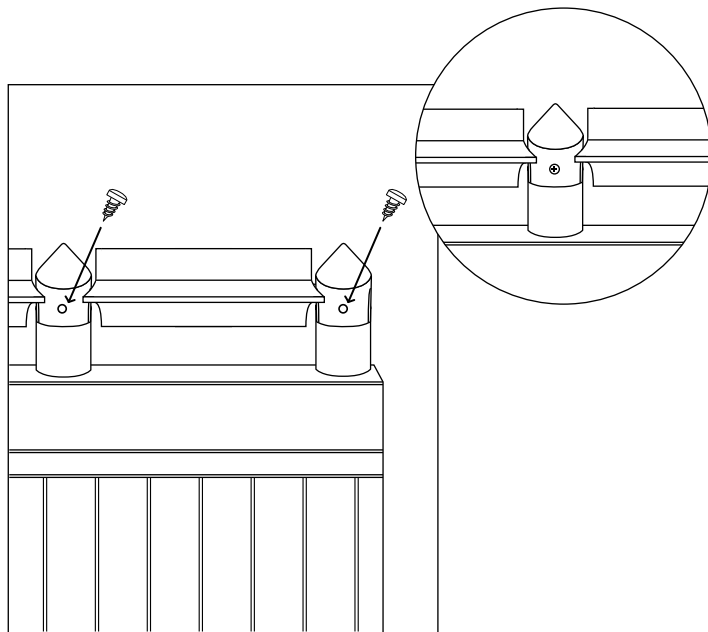

STEP 16

With the 150mm Phillips driver bit attached to your drill, drill a mini screw (7) into each cap.

The bracketed numbers in the steps refer to the part number listed in Parts on page 11.

ADDITIONAL CAT-PROOFING FOR A TIMBER FENCE

In some instances, additional cat-proofing of the fence itself can be required when installing on some fence types, especially timber fences with the posts and rails on the inside of the fence. This is due to the ‘climbability’ aspect, where cats can sink their claws into the timber whilst scaling the fence – giving them the leverage required to scale with enough speed and composure to get over the installed Oscillot®.

Not all of these fences will require additional cat-proofing, but it is something to keep in mind if your cat is particularly agile, determined to escape and can use the horizontal rails as a ladder with ease.

Even if you have a timber fence with posts and rails, Oscillot® can certainly still be the solution to keeping your cat safely at home! If you find that your cat is managing to scramble up your timber fence and over, even after installing Oscillot®, you can install a sheet of polycarbonate below the paddles to cover the horizontal rail and top of the vertical post. This will prevent the cat from being able to get any traction near the top of the fence, preventing the scrambling over and, in conjunction with Oscillot®, making your fence cat-proof.



ELIMINATING PLATFORMS & LADDERS

Oscillot® installed around the perimeter of your fence line is most effective at containing your cats if you have identified and corrected all other routes (other than the fence) that your cat may use to escape your yard.

Your cat may also be using windowsills, outbuildings, trees or roofing to exit your yard.

Block off any spaces between fences and buildings where your cat may squeeze through as well as clothesline structures, planter boxes and raised garden beds etc.

Remove items such as garbage bins, building materials, barbecues etc. near the fence line that may assist your cat to scale fences.

Also remove shrubbery, bushes and trees and tree branches near fences that your cat may use to escape or use tree guards to prevent your cat from climbing trees near the fenceline.



Oscillot® installation with tree guards preventing climbing up the trees in the corner.



Oscillot® installation with rigid polycarbonate blocking off ledge on raised retaining wall eliminating it as a potential platform.

Even with Oscillot® installed, hot water units, gas units and air-conditioning units next to the fence line can make a perfect platform for a cat to jump onto and then leap from in an escape attempt.

It is recommended that these types of platforms are cat-proofed so the cat cannot jump on top of them. This is generally as simple as installing a sheet of rigid, clear polycarbonate sheeting on an angle from the outside edge of the unit up to the wall or fence. This prevents the cat from getting on top of the unit, or if they get on top of the unit, it prevents them jumping.



A rigid sheet of clear polycarbonate installed on an angle up to the wall preventing the cat from using the gas unit as a platform.

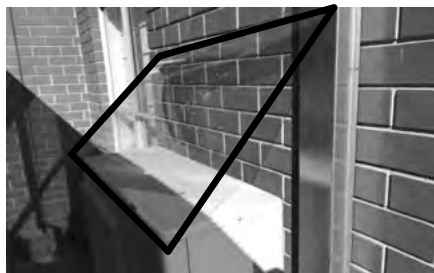

A rigid sheet of clear polycarbonate installed on an angle up to the wall preventing the cat from using the a/c unit as a platform.

ELIMINATING PLATFORMS & LADDERS (CONT.)

It is recommended that sheds are cat-proofed where possible if they are within two metres of the fence line.

Installing Oscillot® on the shed roof perimeter will prevent the cat from jumping on top of the shed and using it to aid in an escape attempt. The same application applies for most shed types, as long as the roof is at least 1.80 metres high and there is a flat surface on top of the shed on which to install the system.



Oscillot® installed around shed roof perimeter to prevent cat from jumping on top of shed.



Oscillot® will spin when cat tries to grab shed roof and cat will not be able to get the required traction and leverage to get on the roof.

If you find that your cat is managing to scramble up your post and rail fence and over, even after installing Oscillot® ...

You can install a sheet of polycarbonate below the paddles to cover the horizontal rail and top of the vertical post. This will prevent the cat from being able to get any traction near the top of the fence, preventing the scrambling over and, in conjunction with Oscillot®, making your fence cat-proof.



Clear polycarbonate sheeting installed just below Oscillot® eliminating the horizontal rail as a potential 'ladder'.



A gate with clear polycarbonate sheeting installed just below Oscillot® eliminating the horizontal rail so the cat cannot use it to get leverage.

INTRODUCING YOUR CAT TO OSCILLOT[®]

Introducing your cat to Oscillot[®] is an important step in training your cat.

SHOW THEM HOW IT WORKS

While securely holding your cat, lift your cat up, place one of its front paws on the paddle and allow it to spin the paddle.

RELEASE ANY OTHER PETS OR WILDLIFE

After installation, we recommend confining your cat indoors for several days to enable you to release, via your gates, any other pets or wildlife that become contained in your yard. These animals will likely not return after being contained the first time. When you do release your cat into the yard, let them out only under supervision for at least one week to ensure that they do not find ways to escape the yard, such as a tree, shed roof or digging under the fence.

SUPERVISE FIRST



If you have recently moved to the property where you have installed Oscillot[®], we recommend confining your cat indoors for four weeks while your cat becomes familiar with its new home environment.

If your cat manages to escape during this period, it might struggle to find its way home. After this initial period, allow your cat supervised access to the yard for short periods and once you are confident that the cat recognises its new home, you can provide full, unsupervised access to the yard.

**Your cats can now play
outdoors safely, a real
investment in peace of mind.**

Oscillot® HQ
7/490 Scottsdale Drive
Varsity Lakes
QLD 4227 Australia

1300 897 340
info@oscillot.com.au

 OscillotCat
 Oscillot_HQ

OSCILLOT.COM.AU