

WISE

SWINGBACK ASSEMBLY INSTRUCTIONS

WD437SS

62 QT Offshore Cooler Seat

PACKAGE CONTENTS

Back cushion, seat cushion, base and hardware

**Questions? Missing Parts?
Please contact store from
which item was purchased**

*Items below are not manufactured
for commercial use.*

Attach Swing Arm Assembly to Base

Attach uprights using 1/4 - 20 x 1-1/2" screw, tighten securely. Repeat on other side.

Attach Swing Arm Assembly to Back

Using 2" screws, mount back cushion to both uprights, tighten assembly.

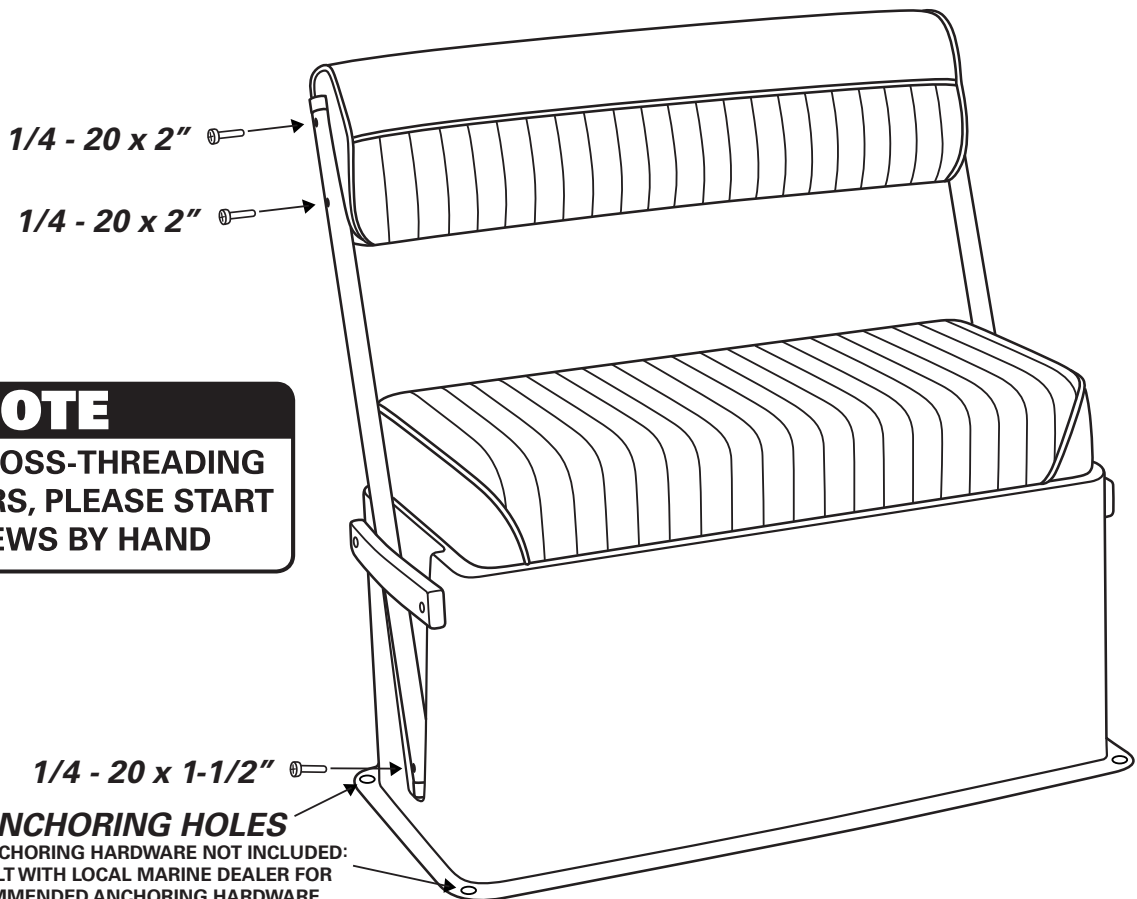

NOTE

**TO AVOID CROSS-THREADING
OF FASTENERS, PLEASE START
ALL SCREWS BY HAND**

THE WISE COMPANY, INC

MANUFACTURERS OF QUALITY MARINE SEATING SINCE 1960

472 WEST 9TH ST. RECTOR, AR 72461 • 1-800-251-2622 • www.wiseseats.com

WL1001