

PARTS LIST

Before starting the actual install, confirm you have all parts listed below:

- (1) Front Rail Hinge Bracket
- (1) Mounting Plate
- (1) Rear Rail Retainer Bracket
- (12) No. 12 x 3/4" Sheet Metal Screws
- (4) No. 14 x 3/4" Sheet Metal Screws (Hex-head)
- (4) 1/4" x 20 x 1/2" Machine Screws
- (4) 1/4" Locking Nuts

TOOLS REQUIRED

To install the 8WD73 on a metal boat seat, we recommend the following tools:

- Electric Drill
- 5/32" Drill Bit for Metal
- Phillips Head Screw Driver
- 3/8" Hex Driver or Bit
- Pliers or Crescent Wrench
- Felt-tip Pen or Soft Lead Pencil

BEFORE INSTALLING, WE RECOMMEND MOUNTING A 8WD10 SWIVEL TO YOUR SEAT

HOW TO INSTALL THE HINGE BRACKET:

1. Position the front rail hinge bracket in the desired place along the front edge of the metal boat seat surface. Use a pen or pencil to mark the location of the screw holes along the top of the bracket (4 hole) and the front of the bracket (6 holes). Remove the hinge bracket and drill pilot holes at each mark using the 5/32" metal bit.

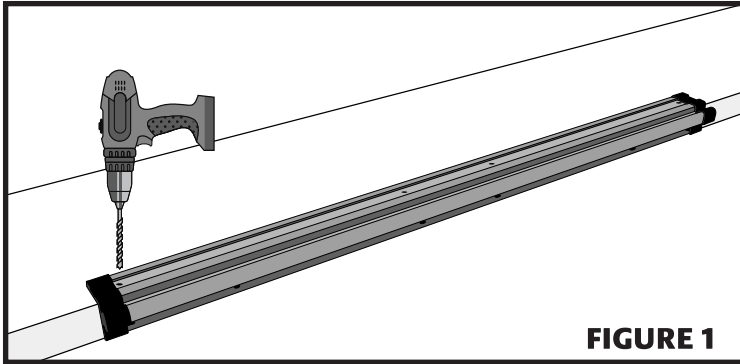

FIGURE 1

2. Replace the hinge bracket and use a 3/8" Hex driver to install the (4) No. 14 x 3/4" screws along the top of the bracket. Use a Phillips head screw driver to install (6) No. 12 x 3/4" screws along the front of the bracket.

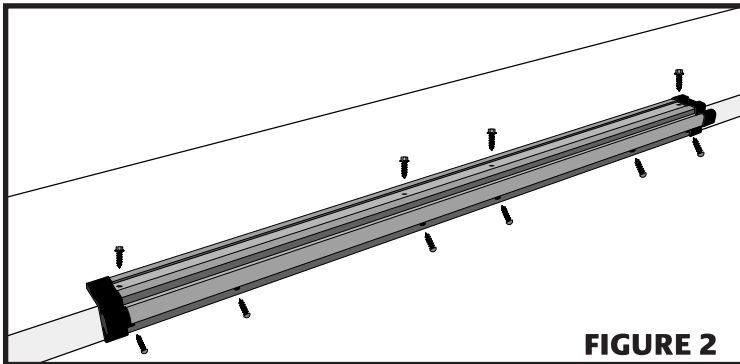

FIGURE 2

HOW TO INSTALL THE MOUNT PLATE:

3. Rotate seat swivel so that mounting holes for the open swivel plate are clear of the swivel plate already installed to the boat seat. Align the slots on the Sure Mount mounting plate to the slots of the seat's swivel plate. Make sure that the "C-hook" on the mounting plate is facing the front edge of your boat seat's bottom cushion and that the open part of the "C-hook" is pointing toward the bottom of the boat seat.

4. Hold a 1/4" lock nut under an open slot on the seat swivel and insert a 1/4" x 20 x 1/2" screw through the open slot of the mounting plate to attach. Hand tighten and repeat until all 4 screws/nuts are connected. Grip each locking nut with pliers or a crescent wrench and drive use the Phillips head screwdriver to complete the fastening of the screw. Repeat until all screws and nuts are fully tightened.

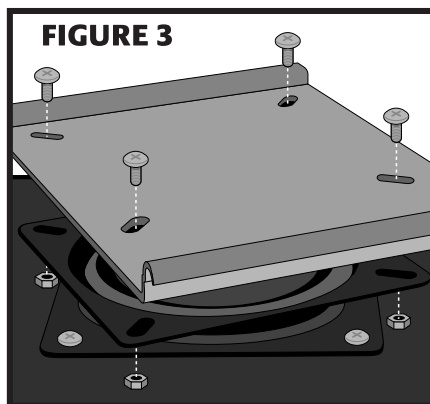

FIGURE 3

HOW TO CONNECT MOUNTING PLATE TO FRONT RAIL HINGE BRACKET:

5. Take notice that the both the mounting plate and the hinge bracket have a "C-hook" design. To connect the bracket to the hinge, first make sure that the front of the bracket is forward facing by rotating the seat swivel. Hold the boat seat in a vertical position so that the "C-hook" of the mounting plate can be received by the "C-hook" of the hinge bracket. Once in place, lower the back side of the seat so it can rotate into its locked position.

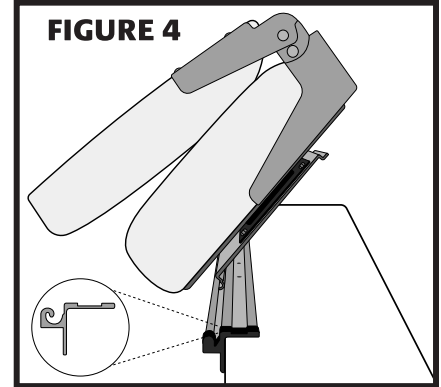

FIGURE 4

To remove the boat seat for storage, simply lift the back of the boat seat and pull forward until the "C-hook" rotates into its open release position.

HOW TO INSTALL THE RETAINER BRACKET:

6. The purpose of the rear rail retainer bracket is to prevent the boat seat from pivoting forward unexpectedly. We recommend that you install the retainer bracket and keep it in place whenever the boat is in motion.

7. To install the retainer bracket, slide the mounted boat seat to the center position of the front rail. Place the retainer bracket (with raised edge facing upward and toward the front rail bracket) over the back edge of the mounting plate so that it sits flush on the metal boat seat surface. Line up the rear rail so that the outer edges line up with the front rail bracket from left to right.

8. Using a pen or pencil, mark the locations of 4 visible screw holes. (6 holes total) **NOTE:** To access the 2 innermost screw holes, you have to slide the seat to the end of one side to mark that location and then to the other side to mark the other location.

9. Remove the retainer bracket and drill pilot holes at each mark using the 5/32" metal bit.

10. Replace the retainer bracket and use a Phillips head screw driver to install (6) No. 12 x 3/4" screws.

11. Now that the retainer bracket is mounted, the installation of the Wise Sure Mount Seat Bracket System is complete and is ready for use.

NOTE: To ensure a smooth back and forth motion of the mounting bracket, you should periodically apply a PTFE based lubricant to the hinge bracket channel.

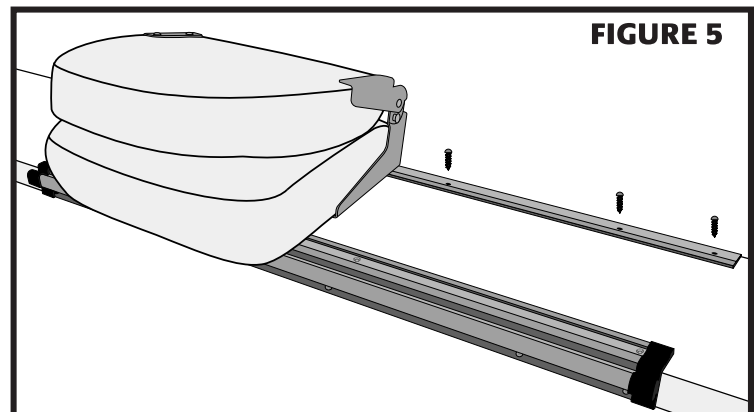

FIGURE 5