

WISE

SWINGBACK COOLER ASSEMBLY INSTRUCTIONS

WD156

70 QUART SWINGBACK COOLER SEAT

WD159

50 QUART SWINGBACK COOLER SEAT

PACKAGE CONTENTS

Back cushion, seat cushion, base and hardware

Attach Swing Arm Assembly to Base

- Attach uprights and washer using 1-1/2" screw, tighten securely.

Attach Swing Arm Assembly to Back

- Using 1-1/2" screws, mount back to uprights, tighten assembly.

NOTE

**TO AVOID CROSS-THREADING
OF FASTENERS PLEASE START
ALL SCREWS BY HAND**

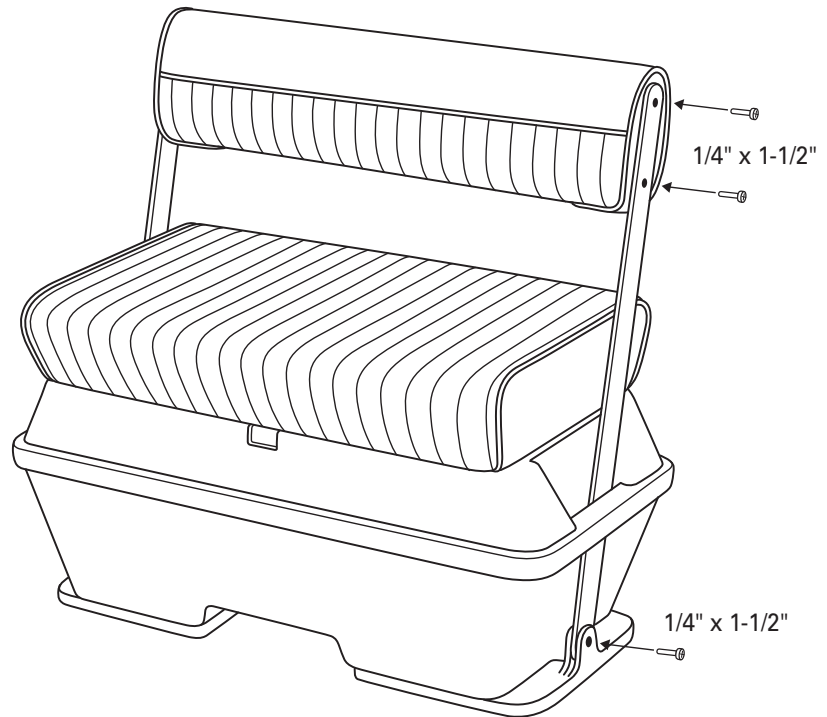

Questions? Missing Parts?
**Please contact store from
which it was purchased**

Above items are not manufactured
for commercial use.

WF1147