



FEATURES

- Economical, lightweight, and handheld general purpose crane scale
- Features an easy to read, backlit LED or LCD display
- Measured values in either pounds (lb) or kilograms (kg)
- Powered using a rechargeable battery pack (up to 80hrs)
- The standard remote controller allows users to change units, clear measurements, zero and tare out weight
- The remote controller can capture peak weight at a distance of up to 100 feet (30m)
- Wireless remote control with Hold function
- 5 years warranty

LED DISPLAY

MODELS	CAPACITY
SL-924A-500	500 lb x .1 lb
SL-924A-1K	1000 lb x .2 lb
SL-924A-1.5K	1500 lb x .5 lb
SL-924A-2K	2000 lb x .5 lb
SL-924A-3K	3000 lb x .5 lb

LCD DISPLAY

MODELS	CAPACITY
SL-924B-500	500 lb x .1 lb
SL-924B-1K	1000 lb x .2 lb
SL-924B-1.5K	1500 lb x .5 lb
SL-924B-2K	2000 lb x .5 lb
SL-924B-3K	3000 lb x .5 lb

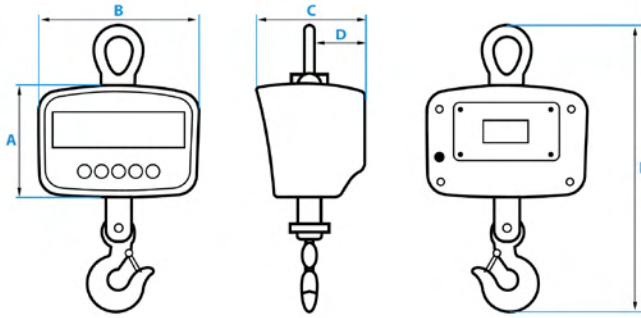

EXTERIOR DIMENSIONS				
A	B	C	D	E
5.88"	8.50"	5.75"	2.91"	15.16"-17.13"

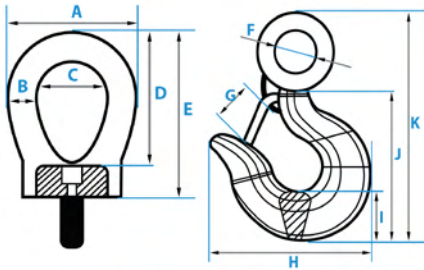

HOOK DIMENSIONS										
A	B	C	D	E	F	G	H	I	J	K
UP TO 2,000 LBS.										
2.55"	0.60"	1.35"	2.65"	3.25"	0.90"	0.90"	2.92"	0.96"	3.15"	4.92"
OVER 2,000 LBS.										
2.55"	0.60"	1.35"	2.65"	3.25"	1.22"	1.15"	3.57"	1.25"	3.90"	6.50"



FEATURES

- Durable cast aluminum housing, ideal for harsh environments and all your overhead weighing needs
- Features an easy to read, backlit LED or LCD display
- Measured values in either pounds (lb) or kilograms (kg)
- Powered using a rechargeable battery pack (up to 80hrs)
- The wireless remote control allows users to change units, clear measurements, zero and tare out weight
- The remote control can capture peak weight at a distance of up to 100 feet (30m)
- Octagonal shape for capacities 3k - 20k
- Rectangular shape for capacity 40k
- 5-years warranty

LED DISPLAY

MODELS	CAPACITY
SL-925A-3K	3000 lb x .5 lb
SL-925A-6K	6000 lb x .5 lb
SL-925A-10K	10000 lb x .5 lb
SL-925A-20K	20000 lb x .5 lb
SL-925A-40K	40000 lb x .5 lb

LCD DISPLAY

MODELS	CAPACITY
SL-925B-3K	3000 lb x .5 lb
SL-925B-6K	6000 lb x .5 lb
SL-925B-10K	10000 lb x .5 lb
SL-925B-20K	20000 lb x .5 lb
SL-925B-40K	40000 lb x .5 lb

6K, 10K, 20K ▼

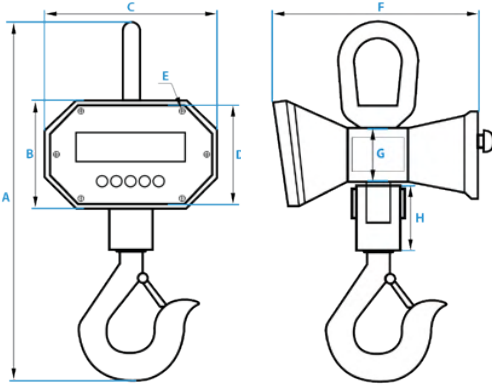

EXTERIOR DIMS. 6K, 10K, 20K			
A	B	C	D
18"; 26"; 29"	6.14"	9.83"	5.65"
E	F	G	H
0.28"	11.2"	2.97"	3.5";6.5";8.5"

Up to 10K lbs ▼

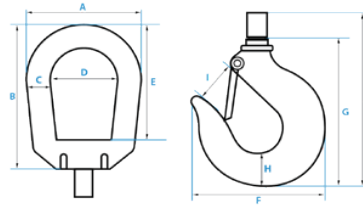

20K lbs ▼

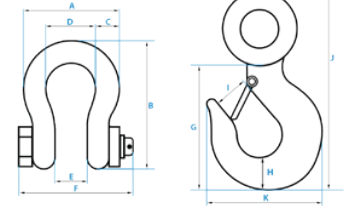

HOOK DIMENSIONS						
CAPACITY	A	B	C	D	E	F
6,000 lbs	4.52"	5.91"	0.95"	3.58"	4.72"	4.54"
10,000 lbs	5.40"	7"	1.25"	2.95"	1.92"	6.50"
20,000 lbs	6"	8"	1.40"	3.21"	2.21"	7.25"
CAPACITY	G	H	I	J	K	
6,000 lbs	5.36"	1.45"	1.45"	6.06"	•	
10,000 lbs	6.40"	1.91"	1.65"	9.50"	6"	
20,000 lbs	8.00"	2.40"	2.00"	12.20"	7.00"	

40,000 lbs ▼

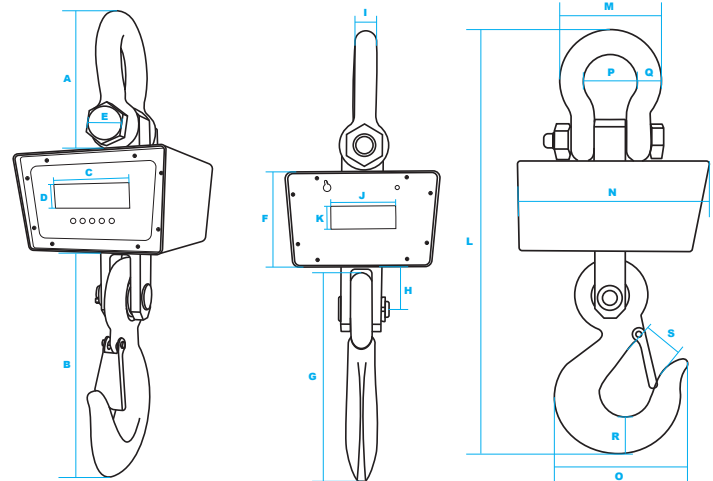

40K LB CAPACITY DIMENSIONS										
A	B	C	D	E	F	G	H	I	J	
5.5"	20"	6"	1.2"	2.9"	7.5"	17"	4.5"	1.95"	5"	
K	L	M	N	O	P	Q	R	S		
1.6"	40"	9.25"	15.75"	13.25"	5"	2.25"	4"	3.4"	•	

60K-100K lbs ▼

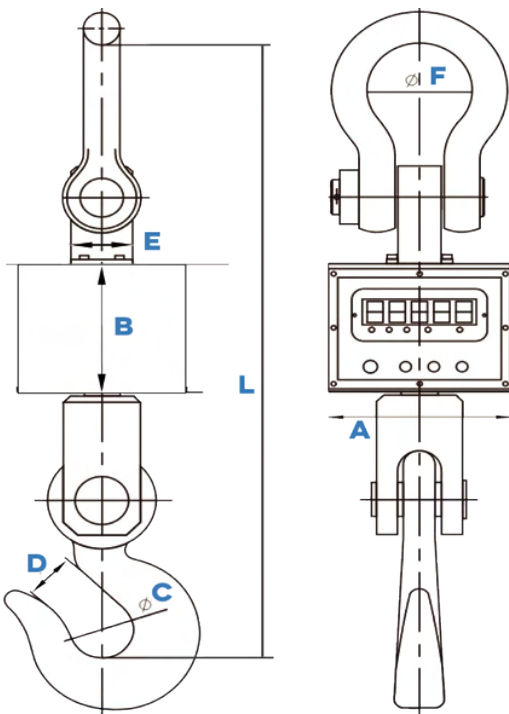

60K-100K lbs ▼

60K-100K LB CAPACITY DIMENSIONS							
CAPACITY	A	B	C	D	E	F	L
60,000 lbs	9.29"	6.25"	5.11"	4.72"	8.34"	5.90"	39.05"
80,000 lbs	11.81"	8.46"	5.90"	5.11"	11.81"	8.42"	47.75"
100,000 lbs	11.81"	8.46"	5.90"	5.11"	11.81"	8.42"	47.75"



MODELS	CAPACITY
SL-926-100	100 lb x 0.01 lb
SL-926-250	250 lb x 0.02 lb
SL-926-500	500 lb x 0.05 lb
SL-926-1K	1,000 lb x 0.1 lb
SL-926-2K	2,000 lb x 0.2 lb
SL-926-3K	3,000 lb x 0.5 lb
SL-926-5K	5,000 lb x 0.5 lb
SL-926-10K	10,000 lb x 1 lb
SL-926-20K	20,000 lb x 2 lb

FEATURES

- General weighing for many applications
- Selectable weighing units: lb, kg
- Includes SL-7516 LED or LCD indicator with rechargeable battery
- Standard indicator functions include Tare, Print, and Peak Hold
- 19' load cell cable (longer cables available)
- Eyebolts included
- Indicator upgrade to NEMA 4 stainless steel for washdown applications
- RS232 port for printer or computer

OPTIONAL ACCESSORIES

- Indicator Upgrade
- Waterproof hard case
- Scoreboard
- Indicator stand
- Software

DIMENSIONS

100 lbs to 20,000 lbs

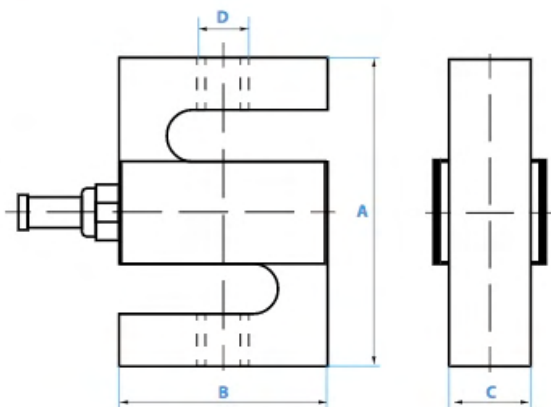

RATED CAPACITY	DIMENSIONS			
	A	B	C	D
LB/INCHES				
100 - 200 lbs	2.50	2.00	0.50	1/4-28UNF-2B
250 - 300 lbs	2.50	2.00	0.50	3/8-24UNF-2B
500 - 1,000 lbs	2.50	2.00	0.75	1/2-20UNF-2B
2K - 3K lbs	3.00	2.00	1.00	1/2-20UNF-2B
5K - 10K lbs	4.25	3.00	1.00	3/4-16UNF-2B
15K lbs	5.50	4.00	1.25	1-12UNF-2B
20K lbs	7.00	5.00	2.00	1 1/4-12UNF-2B
KG/MM				
25 kgs	63.50	50.80	12.70	M6
50 - 70 kgs	63.50	50.80	12.70	M6
100 - 700 kgs	63.50	50.80	19.05	M12
1,000 - 1,500 kgs	76.20	50.80	25.40	M12
2,000 - 5,000 kgs	107.95	76.20	25.40	M20x1.5
7,000 kgs	139.70	101.60	31.75	M20x1.5
10,000 kgs	177.80	127.00	50.80	M30x2



FEATURES

- Designed to measure high capacity load for cranes, hoists, and winches
- Used with shackles to measure force
- Available in capacities ranging from 10,000 lbs to 250,000 lbs
- The display shows both kg and lb measurements
- Cost-effective solution for processing, monitoring, and controlling overhead loads
- Lightweight and compact design with high capacity
- Used with shackles to measure force
- Selectable weighing units: lb and kg
- Power: 110V-220V AC adapter, built-in rechargeable battery (up to 100 hrs)
- 26' load cell cable (longer options available)
- 5-year limited warranty

MODELS	CAPACITY
SL-927-10K	10,000 lb x 1 lb
SL-927-25K	25,000 lb x 10 lb
SL-927-50K	50,000 lb x 20 lb
SL-927-100K	100,000 lb x 50 lb
SL-927-200K	200,000 lb x 100 lb
SL-927-250K	250,000 lb x 100 lb

OPTIONAL ACCESSORIES

- Thermal printers
- Scoreboard (Large display)
- Data collection software
- Explosion proof upgrade
- Water-resistant upgrades
- Output systems (4-20ma or 0-5VRelay)
- Wireless (cordless connection)

RATED CAPACITY	DIMENSIONS					
	A	B	C	D	E	F
lb/inches						
10k lb	11.125	3.55	1.875	7.25	2.015	1.5
25k lb	11.125	3.55	1.875	7.25	2.015	1.5
50k lb	12.2	4.33	2.01	8.27	2.13	1.69
100k lb	16.5	5.0625	2.375	11.875	2.84	1.97
200k lb	23.625	7.09	3.875	15.75	4.6	3.15
250k lb	23.625	7.09	3.875	15.75	4.6	3.15
kg/mm						
4535.92 kg	282.575	90.17	47.625	184.15	51.181	38.1
11339.8 kg	282.575	90.17	47.625	184.15	51.181	38.1
22679.6 kg	309.88	109.982	51.054	210.058	54.102	42.926
45359.2 kg	419.1	128.5875	60.325	301.625	72.136	50.038
90718.4 kg	600.075	180.086	98.425	400.05	116.84	80.01
113398 kg	600.075	180.086	98.425	400.05	116.84	80.01

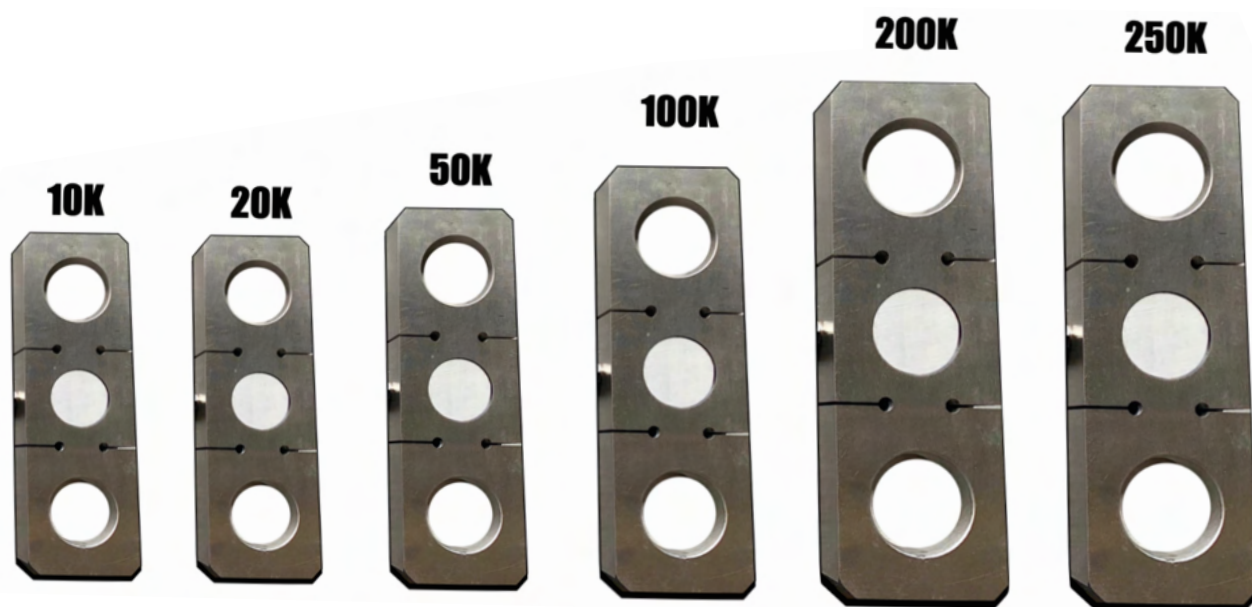
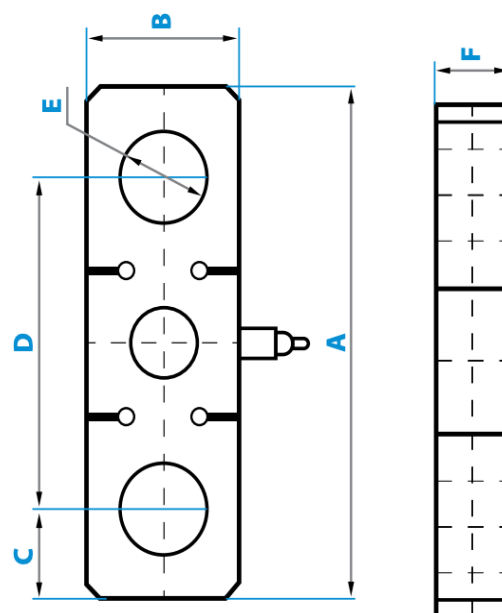



FEATURES

- Designed to measure high capacity load for cranes, hoists, and winches
- Cost-effective solution for processing, monitoring, and controlling overhead loads
- Alloy Steel constructed load cell
- Used with shackles to measure force
- 300 feet wireless range
- 26' load cell cable (longer options available)
- 5-Year Warranty

OPTIONAL ACCESSORIES

- Thermal printers
- Scoreboard (Large display)
- Data collection software
- Explosion proof upgrade
- Water-resistant upgrades
- Output systems (4-20ma or 0-5VRelay)

MODELS	CAPACITY
SL-927-W-10K	10,000 lb x 1 lb
SL-927-W-25K	25,000 lb x 10 lb
SL-927-W-50K	50,000 lb x 20 lb
SL-927-W-100K	100,000 lb x 50 lb
SL-927-W-200K	200,000 lb x 100 lb
SL-927-W-250K	250,000 lb x 100lb

RATED CAPACITY	DIMENSIONS					
	A	B	C	D	E	F
lb/inches						
10k lb	11.125	3.55	1.875	7.25	2.015	1.5
25k lb	11.125	3.55	1.875	7.25	2.015	1.5
50k lb	12.2	4.33	2.01	8.27	2.13	1.69
100k lb	16.5	5.0625	2.375	11.875	2.84	1.97
200k lb	23.625	7.09	3.875	15.75	4.6	3.15
250k lb	23.625	7.09	3.875	15.75	4.6	3.15
kg/mm						
4535.92 kg	282.575	90.17	47.625	184.15	51.181	38.1
11339.8 kg	282.575	90.17	47.625	184.15	51.181	38.1
22679.6 kg	309.88	109.982	51.054	210.058	54.102	42.926
45359.2 kg	419.1	128.5875	60.325	301.625	72.136	50.038
90718.4 kg	600.075	180.086	98.425	400.05	116.84	80.01
113398 kg	600.075	180.086	98.425	400.05	116.84	80.01

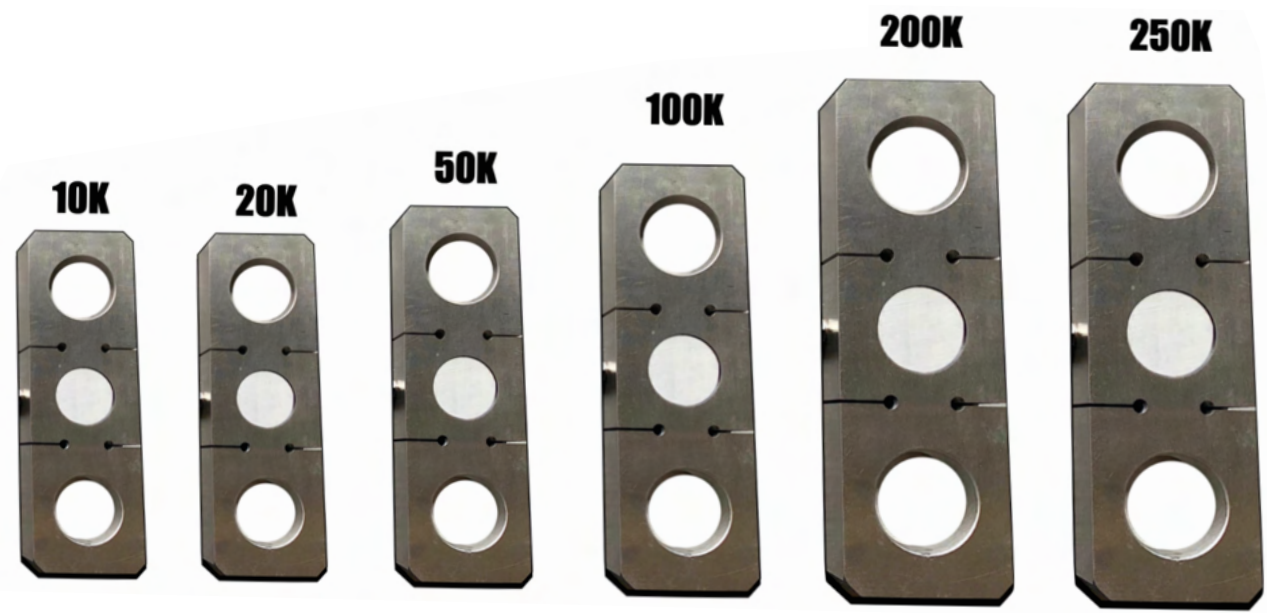
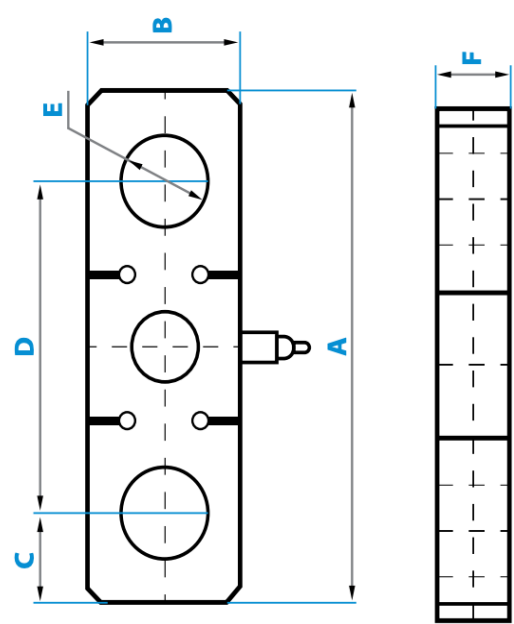



FEATURES

- Completely wireless – operate and display remotely
- Transmission distance: 300ft
- Units of measure: kg/lb
- Easy-grip handheld controller/indicator
- Heavy-duty scale load cell and support
- Package configured and calibrated with 6000 divisions
- Scale power: rechargeable battery
- Additional battery for uninterrupted operation
- 5-year limited warranty

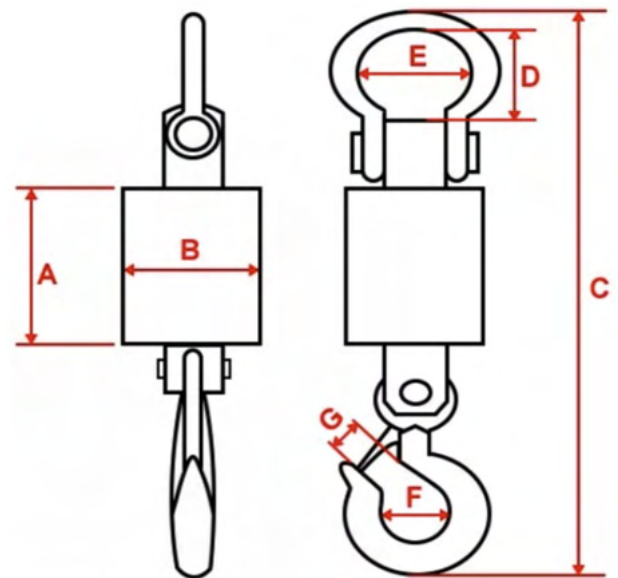

MODELS	CAPACITY	SIZE IN INCH						
		A	B	C	D	E	F	G
SL-W-CR-6K	6,000 lb x 1 lb	4.7	4.3	21.625	4.4	2.5	1.875	1.5
SL-W-CR-10K	10,000 lb x 2 lb	4.7	4.3	24.875	5.25	3	2.5	2.1
SL-W-CR-20K	20,000 lb x 5 lb	4.7	4.3	29.375	5.85	3.8	2.75	2.35