

SL-915 BENCH SCALES



STANDARD



ROLLER TOP



BALL TRANSFER

FEATURES

- Mild steel base, 304 stainless steel pan for easy cleaning
- Adjustable tilt display for convenient viewing
- Aluminum environmentally sealed single point load cell
- Adjustable feet provide exceptional traction
- Standard removable column and wall mounting option
- SL-7510 NTEP indicator with 6 digit, 0.9" display (LED standard)
- Check-weighing feature for quick portioning
- Units: lbs, kgs, (g, oz, lb:oz available on LCD indicator)
- Rechargeable battery (up to 72 hours continuous use) and AC operation
- Tare, Zero, Hold, Counting & Accumulation features
- Built-in RS-232 communication port
- Bubble level

SPECIFICATIONS

- **POWER:** 6V 4Ah rechargeable lead acid battery with 110V power supply
- **FREQUENCY:** 50 or 60 Hz
- **SERIAL COMMUNICATIONS:** Full duplex RS-232, 9600, 4800, 2400, 1200 bps; 8 data bits, 1 stop bits, no parity, no handshaking
- **OPERATING TEMPERATURE:** 5°F to 104°F (-4°C to 40°C)
- **IP RATING:** IP65
- **WARRANTY:** 1 year limited warranty
- **APPROVALS:** NTEP CC 11-016, Class III 5,000 d; Measurement Canada AM-5817, Class III 5,000 d

PART#	DESCRIPTION	CAPACITY	PLATFORM SIZE	SHIP WT.
STANDARD (INC. INDICATOR AND COLUMN)				
SL-915-1212-100	MS ¹ Platform/SS ² Cover	100 lb x 0.02 lb	12" x 12" x 4" H	23 lbs
SL-915-1214-150	MS Platform/SS Cover	150 lb x 0.02 lb	12" x 14" x 4" H	23 lbs
SL-915-1616-300	MS Platform/SS Cover	300 lb x 0.05 lb	16" x 16" x 4.25" H	32 lbs
SL-915-1620-400	MS Platform/SS Cover	400 lb x 0.05 lb	16" x 20" x 4.25" H	38 lbs
SL-915-1818-400	MS Platform/SS Cover	400 lb x 0.05 lb	18" x 18" x 4.25" H	38 lbs
SL-915-2020-500	MS Platform/SS Cover	500 lb x 0.1 lb	20" x 20" x 4.25" H	62 lbs
SL-915-1824-500	MS Platform/SS Cover	500 lb x 0.1 lb	18" x 24" x 5.5" H	64 lbs
SL-915-2424-500	MS Platform/SS Cover	500 lb x 0.1 lb	24" x 24" x 5.5" H	70 lbs
SL-915-2424-1K	MS Platform/SS Cover	1,000 lb x 0.2 lb	24" x 24" x 5.5" H	70 lbs
SL-915-3030-1K	MS Platform/SS Cover	1,000 lb x 0.2 lb	30" x 30" x 5.5" H	70 lbs
WITH STAINLESS BALL TRANSFER TOP (INC. INDICATOR AND COLUMN) ALSO AVAILABLE IN STAINLESS STEEL				
SL-915BT-1616-300	Ball Transfer Cover	300 lb x 0.05 lb	16" x 16" x 4.25" H	32 lbs
SL-915BT-2020-500	Ball Transfer Cover	500 lb x 0.1 lb	20" x 20" x 4.25" H	62 lbs
SL-915BT-2424-500	Ball Transfer Cover	500 lb x 0.1 lb	24" x 24" x 5.5" H	70 lbs
SL-915BT-2424-1K	Ball Transfer Cover	1,000 lb x 0.2 lb	24" x 24" x 5.5" H	70 lbs
WITH STAINLESS ROLLER CONVEYOR TOP (INC. INDICATOR AND COLUMN) ALSO AVAILABLE IN STAINLESS STEEL				
SL-915RT-1818-400	Roller Top Cover	400 lb x 0.05 lb	18" x 18" x 4.25" H	38 lbs
SL-915RT-2424-500	Roller Top Cover	500 lb x 0.1 lb	24" x 24" x 5.5" H	70 lbs
SL-915RT-2424-1K	Roller Top Cover	1,000 lb x 0.2 lb	24" x 24" x 5.5" H	70 lbs

SL-915SS STAINLESS STEEL BENCH SCALES



HIGH PRECISION



STANDARD

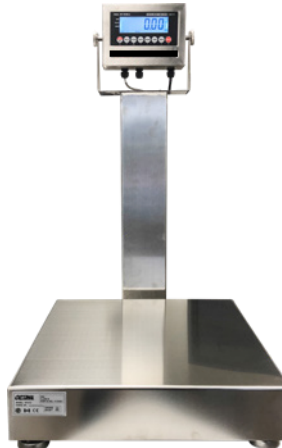

FEATURES

- Stainless steel base, stainless steel platform
- Large 0.9" backlit LCD indicator with a rechargeable battery and watersealed AC Adapter
- Stainless steel load cell with hardwired cable to indicator for maximum water protection
- Detachable column and tilt stand for table, wall or under counter mounting
- Overload stops on scale base
- Measurement units: lb, kg (g, lb:oz, oz - Not Legal for Trade)
- Lower/upper limit alarm
- Counting feature (Not Legal for Trade)
- Accumulation feature
- Check-weighing feature for quick portioning
- Level bubble

SPECIFICATIONS

- **POWER:** 6V 4Ah rechargeable lead acid battery with 110V power supply
- **FREQUENCY:** 50 or 60 Hz
- **SERIAL COMMUNICATIONS:** Full duplex RS-232, 9600, 4800, 2400, 1200 bps; 8 data bits, 1 stop bits, no parity, no handshaking
- **OPERATING TEMPERATURE:** 5°F to 104°F (-4°C to 40°C)
- **IP RATING:** IP67
- **WARRANTY:** 1 year limited warranty
- **APPROVALS:** NTEP CC 11-016, Class III 5,000 d; Measurement Canada AM-5817, Class III 5,000 d

PART#	DESCRIPTION	CAPACITY	PLATFORM SIZE	WEIGHT
HIGH PRECISION¹ (INC. INDICATOR AND COLUMN)				
SL-915SS-HP-6	All Stainless Steel High Precision	6lb x 0.0002lb / 3kg x 0.1g	10" x 10" x 4" H	21 lbs
SL-915SS-HP-15		15lb x 0.0005lb / 7.5kg x 0.2g	10" x 10" x 4" H	21 lbs
SL-915SS-HP-30		30lb x 0.001lb / 15kg x 0.5g	10" x 10" x 4" H	21 lbs
SL-915SS-HP-60		60lb x 0.002lb / 30kg x 1 g	10" x 10" x 4" H	21 lbs
STANDARD (INC. INDICATOR AND COLUMN)				
SL-915SS-1212-100	All Stainless Steel	100 lb x 0.02 lb	12" x 12" x 4" H	29 lbs
SL-915SS-1214-150	All Stainless Steel	150 lb x 0.02 lb	12" x 14" x 4" H	31 lbs
SL-915SS-1616-300	All Stainless Steel	300 lb x 0.05 lb	16" x 16" x 4.25" H	40 lbs
SL-915SS-1620-400	All Stainless Steel	400 lb x 0.05 lb	16" x 20" x 4.25" H	47 lbs
SL-915SS-1818-400	All Stainless Steel	400 lb x 0.05 lb	18" x 18" x 4.25" H	47 lbs
SL-915SS-2020-500	All Stainless Steel	500 lb x 0.1 lb	20" x 20" x 4.25" H	66 lbs
SL-915SS-1824-500	All Stainless Steel	500 lb x 0.1 lb	18" x 24" x 5.5" H	66 lbs
SL-915SS-2424-500	All Stainless Steel	500 lb x 0.1 lb	24" x 24" x 5.5" H	86 lbs
SL-915SS-2424-1K	All Stainless Steel	1,000 lb x 0.2 lb	24" x 24" x 5.5" H	87 lbs

SL-915BW PORTABLE BENCH SCALES



ALL STAINLESS
STEEL



STANDARD
DIAMOND PLATE



STANDARD
WITH SS COVER

FEATURES

- Convenient portable weighing platform with wheels
- Easily moves in any work area
- 27.5" backrail for pushing or pulling
- Swivel wheel casters come with brakes in the back
- High accuracy stainless steel load cells
- Rechargeable batter (up to 100 hrs)
- Hinged indicator bracket
- IP Rating: Standard- IP65, Stainless Steel- IP67
- Legal for Trade: NTEP approved CC# 11-016
- Measurement Canada CC# AM-5817

PART #	DESCRIPTION	CAPACITY	PLATFORM SIZE	SHIP WT.
STANDARD (INC. INDICATOR AND COLUMN)				
SL-915BW-1824-500	Mild Steel Platform / Stainless Steel Cover	500 lb x 0.1 lb	18" x 24" x 10" H	92 lbs
SL-915BWDP-1824-500	Mild Steel Platform / Diamond Plate Cover	500 lb x 0.1 lb	18" x 24" x 10" H	94 lbs
SL-915BW-2424-1000	Mild Steel Platform / Stainless Steel Cover	500 lb x 0.1 lb	24" x 24" x 10" H	106 lbs
SL-915BWDP-2432-1000	Mild Steel Platform / Diamond Plate Cover	1,000 lb x 0.2 lb	24" x 32" x 10" H	149 lbs
STAINLESS STEEL WASHDOWN (INC. INDICATOR AND COLUMN)				
SL-915SSBW-1824-500	All Stainless Steel	500 lb x 0.1 lb	18" x 24" x 10" H	78 lbs
SL-915SSBW-2424-500	All Stainless Steel	500 lb x 0.1 lb	24" x 24" x 10" H	95 lbs

SL-915-BC BENCH SCALE CART

FEATURES

- For use with SL-915-SS bench scales
- Stainless steel welded construction
- Ideal for use in the food or chemical industry
- Wheeled design for effortless smooth movement, easy portability and fast set up
- Locking rear casters allows for stability
- Adjustable cart legs can be raised or lowered to fit into assembly lines
- Rear handle for easy transporting
- Removable indicator stand
- Tilt-able indicator for eliminating glare
- 1,000 lb capacity

PART#	SIZE	SHIP WT.
SL-915-CT18	For 18" x 18" platforms	50 lbs
SL-915-CT24	For 24" x 24" platforms	70 lbs

* SHOWN WITH BENCH SCALE (SOLD SEPARATELY)

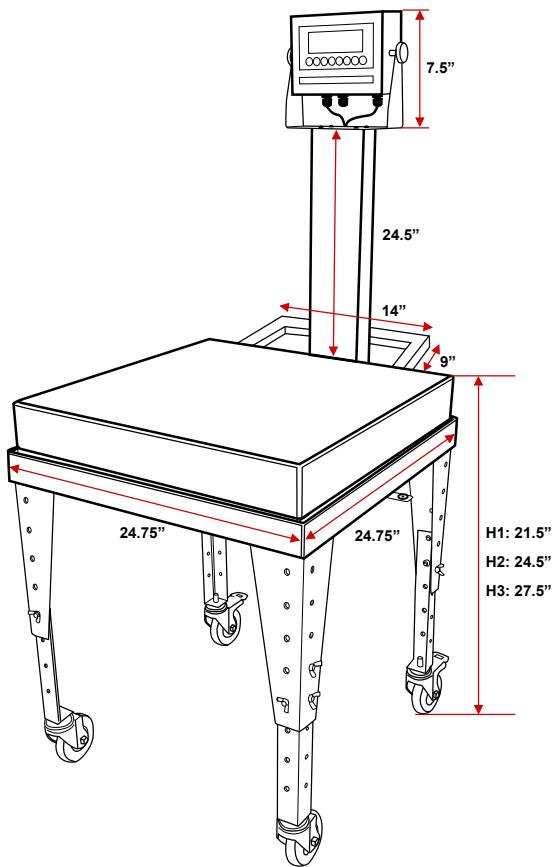

* SHOWN WITH 4 CASTERS (OPTIONAL)