

# Instructions for the EKKO PLATFORM BED - TWIN

SKU# 8313-EK-T









Manufactured by



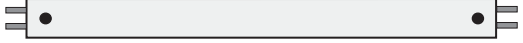

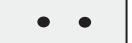

**kd frames**

394 Dairy Pak Rd. • Athens, GA 30607  
kdframes.com • customerservice@kdframes.com

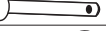
## PARTS LIST

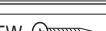
(2) E-10 CENTER LEG - 10"		(4) E-39 BED SLAT - 39"
		(12) E-35 MIDDLE SLAT - 35"
		(3) E-27 LEG CONNECTOR - 27"
(4) E-9 END LEG - 9"		(4) E-33 SLAT CAP - 33"
		(2) E-8 RAIL CONNECTOR
		(4) E-38 BED RAIL - 38"

## HARDWARE

H-8	2-1/4" CLEVIS PIN		8
H-12	3-1/4" CLEVIS PIN		4
H-5	HAIR PIN		12
H-11	WOOD DOWEL		16
H-19	1 - 3/4" WOOD SCREW		8
H-21	2-1/2" BOLT		6
H-3	CROSS DOWELL		6
H-10	HEX WRENCH		1

Tulip Poplar is a beautiful hardwood species that has some slight color in parts of the tree. We make every attempt to use creamy colored wood on parts that show and the wood with color in parts that are hidden such as bed slats. Any green tint in the wood will change brown after several weeks or after exposure to direct sunlight for about 30 minutes. For more information on our products please visit us at [kdframes.com](http://kdframes.com).

### STEP 1

Push 4 Wood Dowels (H-11) into edge holes on all 4 Bed Rails (E-38) as shown.



### STEP 2

Assemble the Slat Decks by pressing (6) Middle Slats (E-35) into (2) Slat Caps (E-33). Then press (2) Bed Slats (E-39) onto the Slat Caps. Repeat for the other Slat Deck.

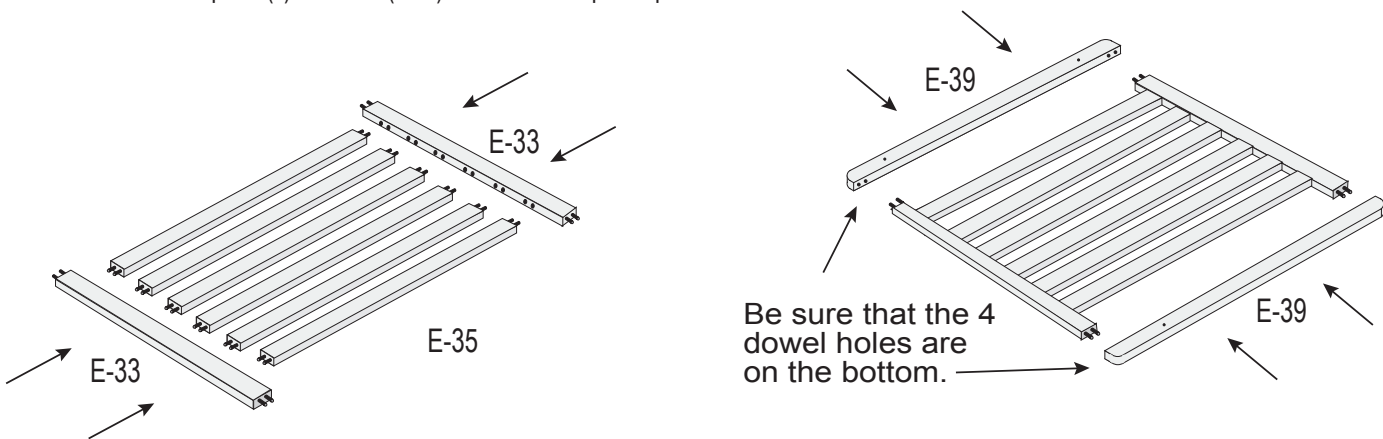

### STEP 3

Press an End Leg (E-9) onto the wood dowels on each end of a Leg Connector (E-27). Attach the End Legs with 2-1/2" bolts (H-21) and cross dowels (H-3). Repeat for the other end leg assembly.

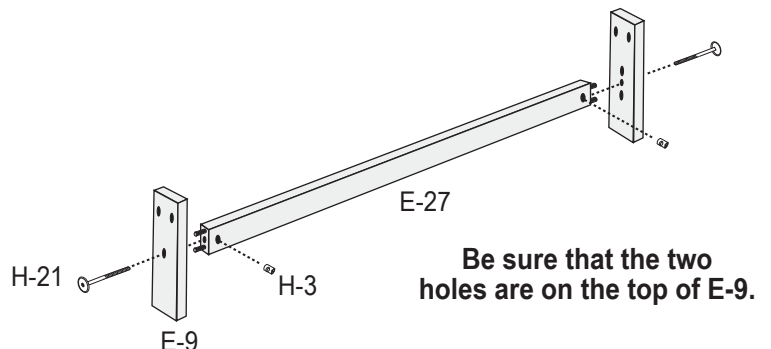

#### STEP 4

Press a Center Leg (E-10) onto the wood dowels on each end of a leg connector (E-27). Attach the center legs with 2-1/2" bolts (H-21) and cross dowels (H-3).

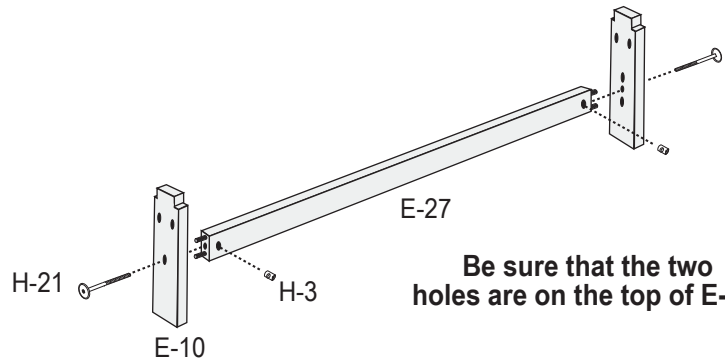

Be sure that the two holes are on the top of E-10.

#### STEP 5

Use (8) 2-1/4" Clevis Pins (H-8) and (4) 3-1/4" Clevis Pins (H-12) to Attach (2) Bed Rails (E-38) to the Leg Assemblies from Step 3 and Step 4.

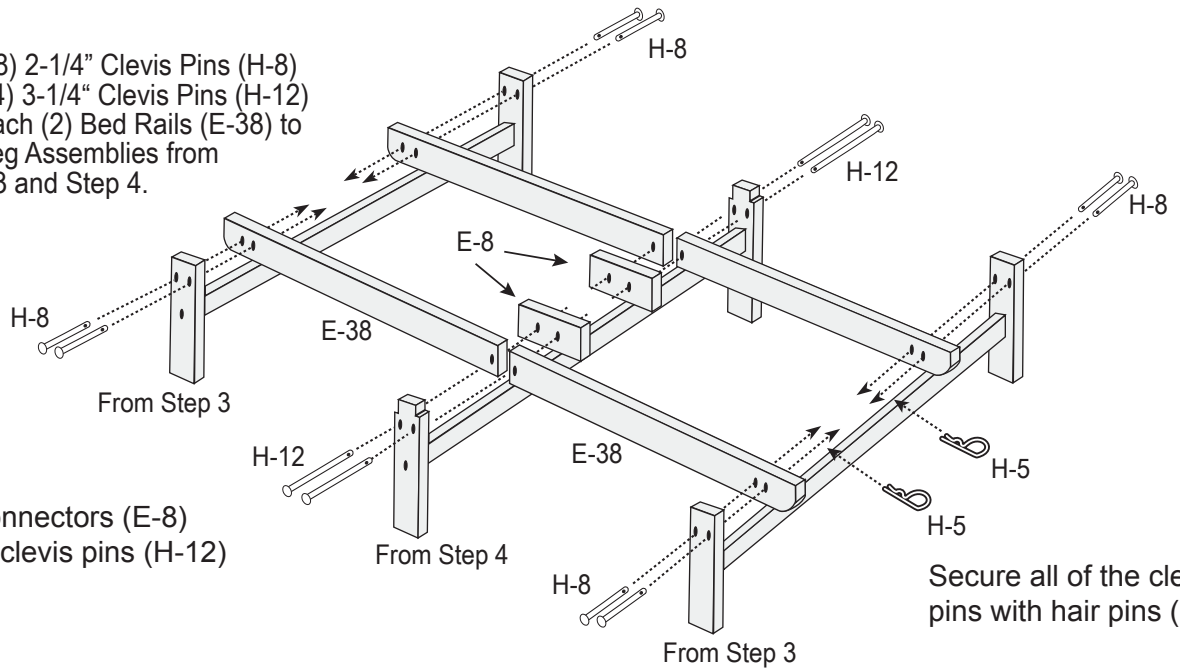

Slide the rail connectors (E-8) onto the 3-1/4" clevis pins (H-12)

Secure all of the clevis pins with hair pins (H-5)

#### STEP 6

Push the Slat Decks down onto the wood dowels and attach with Wood Screws (H-19).

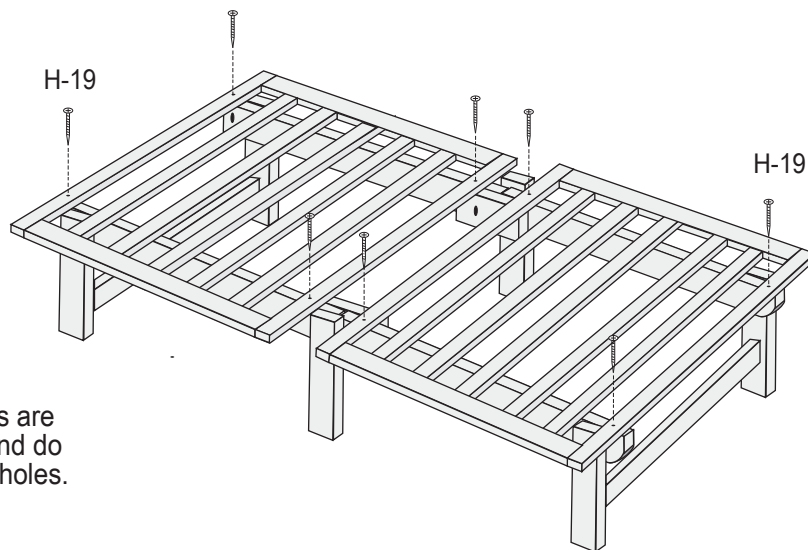

Note:  
Wood Screws are self tapping and do not need pilot holes.

Tulip Poplar can be left unfinished, clear finished, stained, or painted. I prefer the lighter stains over the darker ones because the wood is fairly porous. My favorite is a clear finish with no stain. Satin polyurethane (oil or water based) works well.

**Painting:** It is best to start with an interior primer and lightly sand before painting.

**Staining:** Lightly sand before staining. Wipe stain on with a rag until you get the desired color. If you are going to use a top coat (such as polyurethane), do not sand again until after the first coat, and then be careful not to sand away the stain.

**Finishing:** All finishes work well with Tulip Poplar. A simple wax finish over stain (Minwax for example) is easy. An oil finish such as Danish oil can be used. Or a clear top coat such as polyurethane works well to seal the wood. With polyurethanes, the first coat acts as a sanding sealer. So you should lightly sand (180 - 220 grit sandpaper) after the first coat, wipe the wood clean, and then build up coats for the desired effect.