

Instructions for the  
**TWIN TRUNDLE BED**

SKU# 7903-TR-T



Manufactured by

**kd frames**

394 Dairy Pak Rd. • Athens, GA 30607  
kdframes.com • customerservice@kdframes.com

PARTS LIST

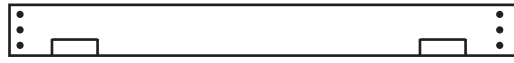

(2) N-37 END CONNECTORS (37.5")



(2) N-71 BED RAILS (71")

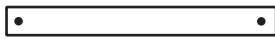

(2) N-36C CONNECTOR SLATS (36")

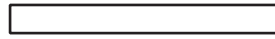

(12) N-36 REGULAR SLATS (36")

HARDWARE LIST

H-21	2 - 1/2" BOLT		8
H-3	CROSS DOWEL		8
H-10	HEX WRENCH		1
H-W	WHEELS		4
H-34	3/4" WOOD SCREWS		8
H-11	WOOD DOWEL		8
#2 PHILLIPS HEAD SCREW DRIVER REQUIRED			

STEP 1

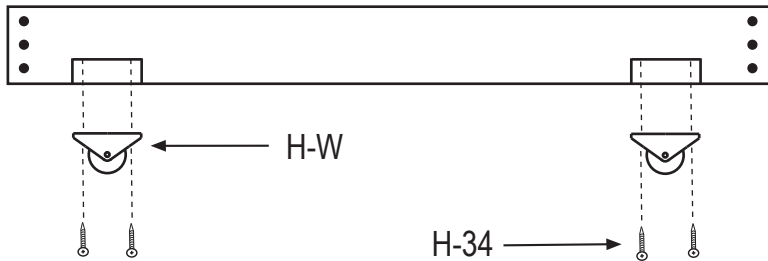

Attach two Wheels (H-W) to one of the the End Connectors (N-37) using four of the the 3/4" Wood Screws (H-34). Repeat for the other End Connector.

STEP 2

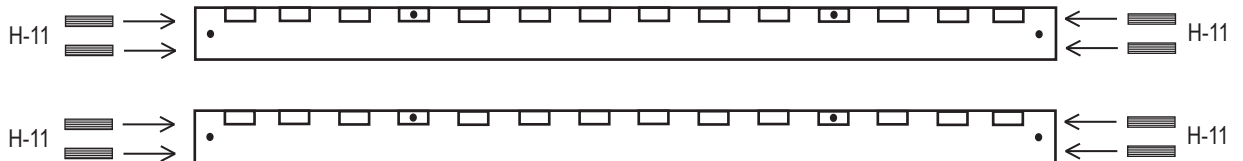

Insert the (8) H-11 wood dowels into the corresponding holes in the ends of the (2) N-71 bed rails.

STEP 3

First, make sure that the Wheels are on the bottom of the End Connector and then attach to N-71 Bed Rails. Make sure pockets on rails face toward inside. Use 2-1/2" Bolts (H-21) and Cross Dowels (H-3) to attach as shown. Tighten with H-10 hex wrench.

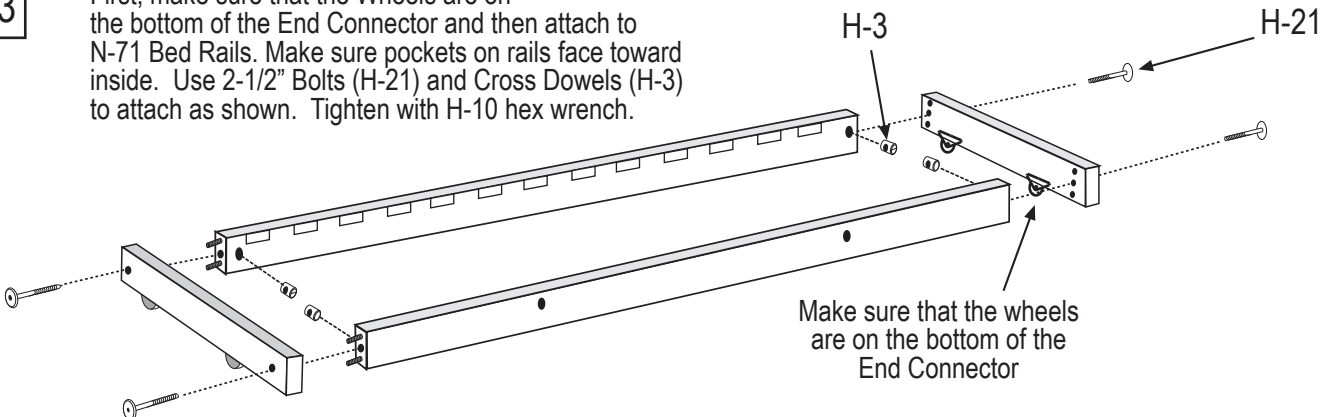

## STEP 4

Insert all slats into corresponding rail pockets. Be sure connector slats are placed in rail pockets with the holes.

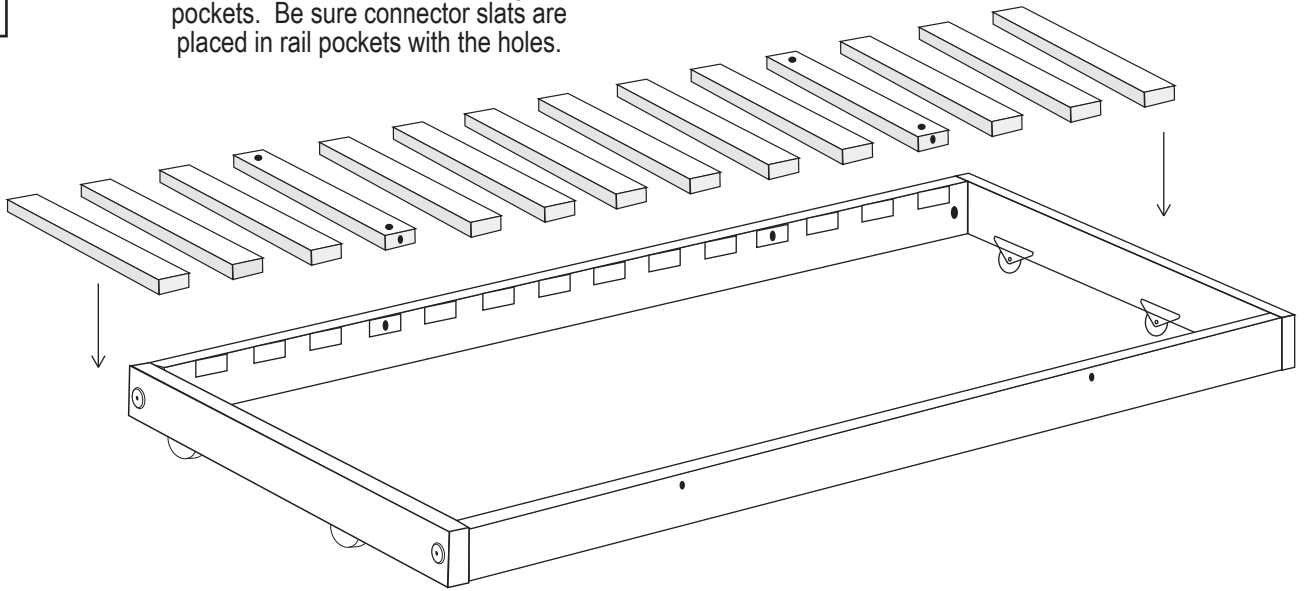

## STEP 5

Secure connector slats using 2 1/2" Bolts (H-21) and Cross Dowels (H-3) as pictured. Tighten all bolts with H-10 hex wrench.

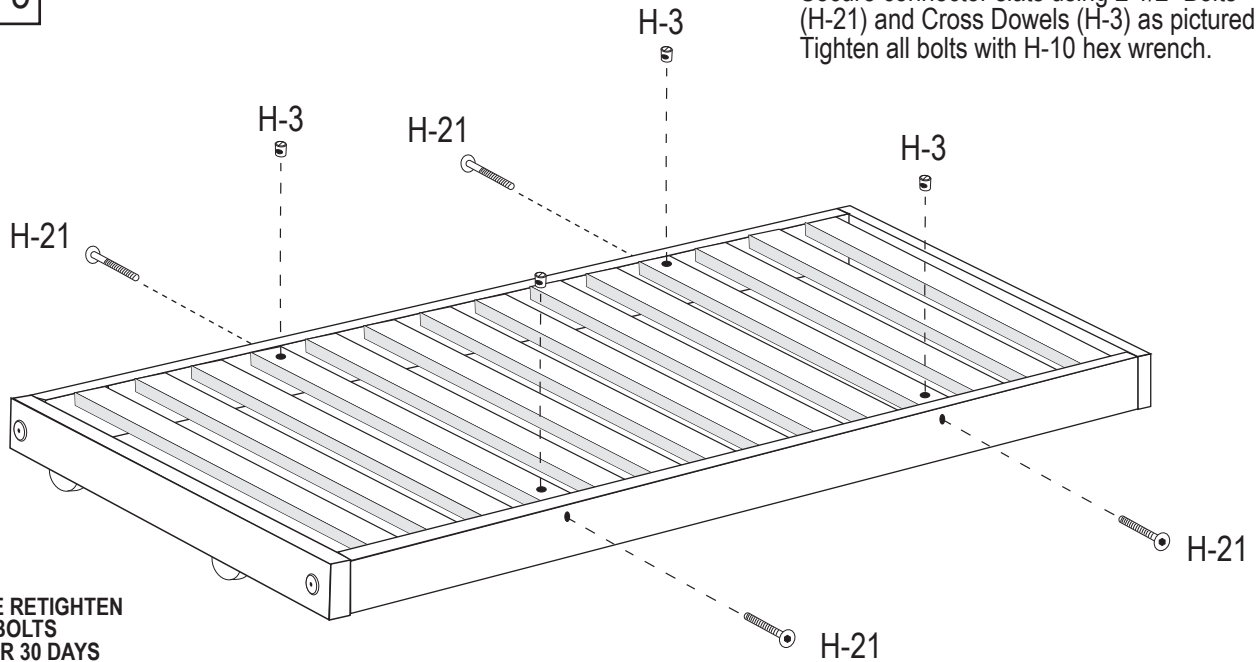

PLEASE RETIGHTEN  
BOLTS  
AFTER 30 DAYS

This futon frame is made with Tulip Poplar. Any green tint in the wood will change to light brown in a few weeks. This will happen in 20 to 30 minutes if placed in direct sunlight. Tulip Poplar can be left unfinished, clear finished, stained, or painted. I prefer the lighter stains over the darker ones because the wood is fairly porous. My favorite is a clear finish with no stain. Satin polyurethane (oil or water based) works well.

**Painting:** It is best to start with an interior primer and lightly sand before painting.

**Staining:** Lightly sand before staining. Wipe stain on with a rag until you get the desired color. If you are going to use a top coat (such as polyurethane), do not sand again until after the first coat, and then be careful not to sand away the stain.

**Finishing:** All finishes work well with Tulip Poplar. A simple wax finish over stain (Minwax for example) is easy. An oil finish such as Danish oil can be used. Or a clear top coat such as polyurethane works well to seal the wood. With polyurethanes, the first coat acts as a sanding sealer. So you should lightly sand (180 - 220 grit sandpaper) after the first coat, wipe the wood clean, and then build up coats for the desired effect.