

Instructions for the  
**NOMAD PLATFORM BED**  
**CALIFORNIA KING**

SKU# 2876-NP-CK



Manufactured by

**kd frames**

394 Dairy Pak Rd. • Athens, GA 30607  
 kdframes.com • customerservice@kdframes.com

Parts:

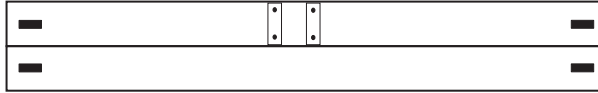

(2) A-66F BED ENDS - 66"



(4) A-84-P BED RAIL - 84"



(30) A-33 REGULAR SLAT - 33"



(4) A-33-C CONNECTOR SLAT - 33"



(2) A-15L  
LEFT LEGS -15"



(2) A-15R  
RIGHT LEGS -15"



(2) A-14  
CENTER LEGS -14"

**H A R D W A R E L I S T**

H-21	2 - 1/2" BOLT		24
H-3	CROSS DOWEL		24
H-10	HEX WRENCH		1
H-20	1 - 1/2" WOOD SCREW		16

#2 PHILLIPS HEAD SCREW DRIVER REQUIRED

FOR ASSEMBLY VIDEO PLEASE VISIT

[kdframes.com](http://kdframes.com)

1

Align a Left Leg (A-15L) and Right Leg (A-15R) so that the rail pockets are on the front. Turn the Bed End (A-66F) so that the pocket holes are facing the front. Then push the dowels into the holes on the legs. Repeat for the other Bed End.

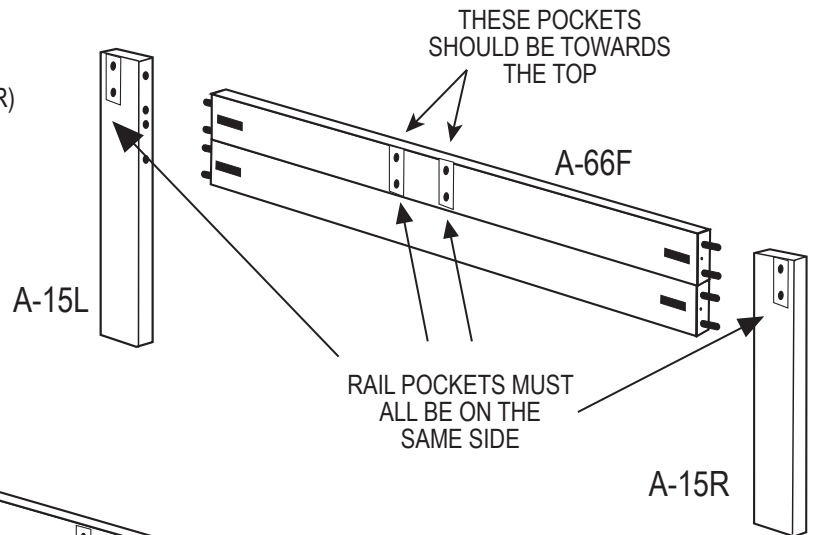

Use a phillips screw driver to attach the Legs to the Leg Connector using (4) 1 - 1/2" Wood Screws (H-20). Repeat for the other Bed End.

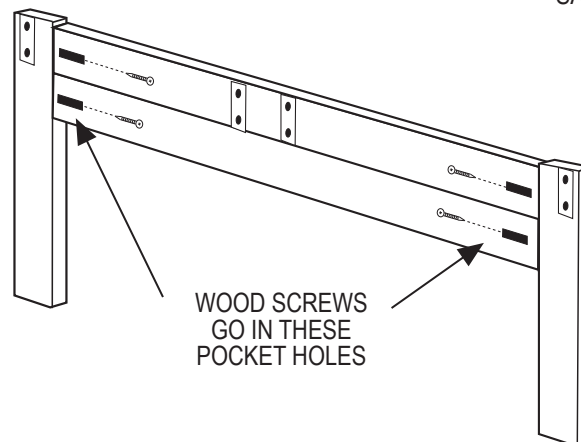

2

Use 2 - 1/2" Bolts (H-21) and Cross Dowels (H-3) to attach Bed Rails (A-84-P) to the Bed Ends. The pockets in the Bed Rails should be facing in and open to the top.

Leave all bolts loose until everything is attached. Then tighten all bolts.

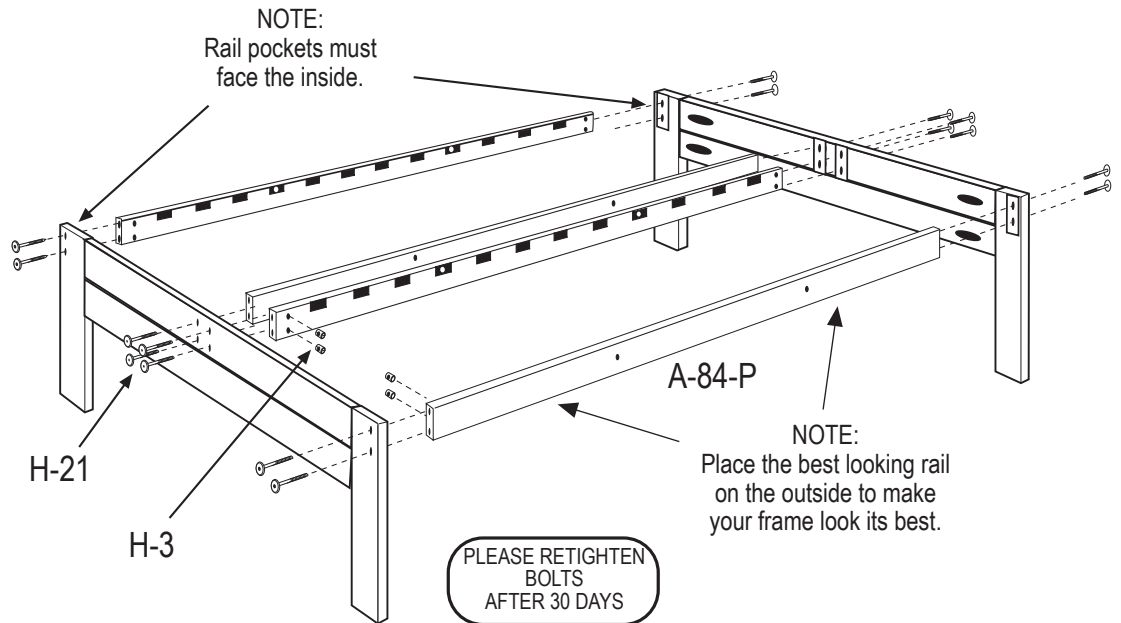

3

Use (8) 1-1/2" Wood Screws (H-20) to attach one Center Leg (A-14) to the center of each of the two middle Bed Rails.

Note: The Wood Screws are self-tapping so they do not need pilot holes.

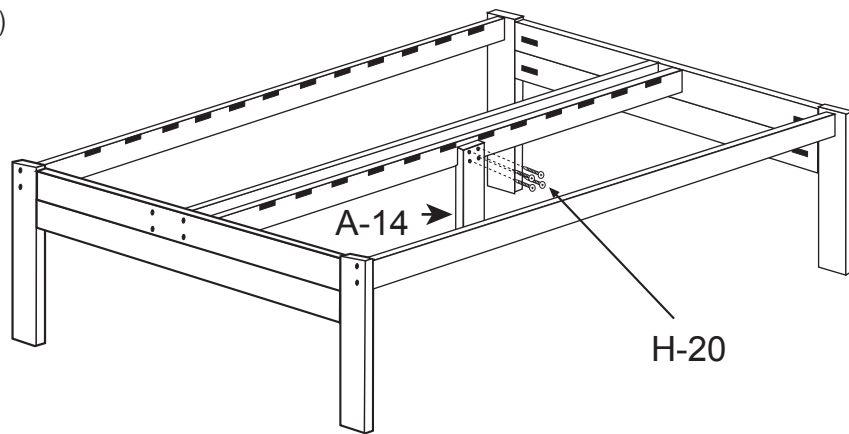

4

Insert (4) Connector Slats (A-33-C) into the pockets that have holes. Secure using 2-1/2" Bolts (H-21) and Cross Dowels (H-3). Leave these loose at this time.

Next insert all Regular Slats (A-33), then tighten the 2 - 1/2" Bolts (H-21).

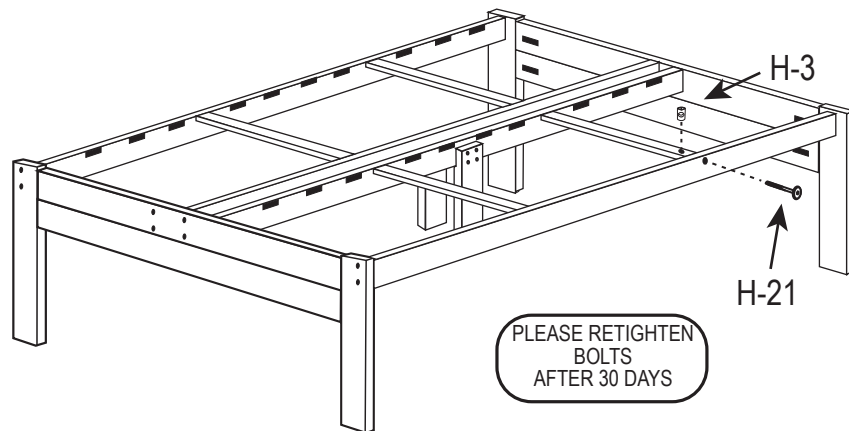

This bed frame is made with Tulip Poplar. Any green tint in the wood will turn to light brown in a few weeks. This will shapen in 30 minutes if exposed to direct sunlight. Tulip Poplar can be left unfinished, clear finished, stained, or painted. Lighter stains work better over dark as the wood is fairly porous. It is best to start with an interior primer and lightly sand if painting. For staining, lightly sand and wipe the stain on with a rag until you achieve the desired color. All finishes work well with Tulip Poplar. A simple wax finish over the stain (Minwax for example) is easy. An oil finish such as Danish oil can be used. Or a clear top coat such as polyurethane works well to seal the wood. With polyurethane, the first coat acts as a sanding sealer, so you should lightly sand (180-220 grit sandpaper) after the first coat, wipe the wood clean, and then build up coats for the desired effect. Knockdown Frameworks, Inc. warrants all of its products for five years against any defects that are due to faulty materials or workmanship. We will promptly correct such defects by repair or replacement, at our option, without charge. This warranty covers product defects only and will expire five years after date of purchase by the original consumer purchaser, with proof of purchase required. This warranty does not apply to damage caused by and resulting from misuse, neglect, accident, or improper operation, maintenance, storage, transportation, or handling of the product. This warranty is for the original consumer purchaser for residential use only and does not apply if the product is used in any commercial application (such as rental property). This warranty does not cover any incidental or consequential damages. If you feel that you have a claim under this warranty, please contact the store from which it was purchased. If this is not possible, call 706-543-9397 for advice on handling your claim.