

A guide for riders

Welcome to Cowboy. Your new bike has arrived, and with it a new way to move freely and mindfully through your city. As you map your own path, we'll be there to power you forward, open to the road ahead.



Watch the video

Visit us.cowboy.com to find additional information about cycling safety and maintenance. You can also take a look at our assembly tutorial video to get you started at cowboy.com/pages/tutorials

Cowboy, Inc.
45 Pleasant St
Unit 1
Newburyport, MA 01950
U.S.A.
us.cowboy.com





Contents

This guide will get your new bike ready to ride and provide you with important assembly, riding, safety, and maintenance information.

Get ready

- What's in the box
- The set-up
- Know your bike

Connect

- Pair the app

Ride

- Accessories
- Before every ride
- Before your first ride
- Bike maintenance

Wherever *'Warning'* appears throughout these pages, imminent potential risks to your safety or health are discussed. Please comply with all instructions and take appropriate preventive measures.

00

What's in the box

While tightening a screw with Allen keys 3, 5, and 6, insert the short end for greater leverage. Do not use power tools.

You may want to install accessory lights and reflectors to be more visible to others on the road. Install them in accordance with state and local safety rules. An installation guide is available at cowboy.com/pages/tutorial

Battery keys x2

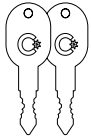

Battery charger

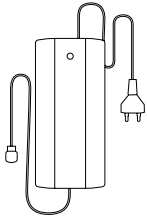

Pedals x2

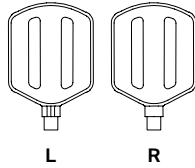

Pin wrench

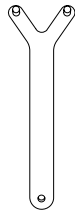

Allen key 3



Butterfly Allen key 4



Allen key 5

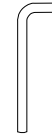

Allen key 6

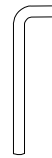

The set-up

All the Cowboy essentials are in your hands. Follow the instructions, and in just a few steps you'll have your bike put together.

To assemble

Handlebar
Brakes
Pedals
Saddle
Wireless charging

The essentials

01 Taillight
02 Removable battery
03 Fenders
04 Rear hub motor
05 Puncture-resistant tires
06 Carbon belt drive
07 Pedals
08 Hydraulic disc brakes
09 Headlight
10 Cockpit with wireless phone charger
11 Frame
12 Adjustable saddle

C4 Suitable size: 5'5" to 6'2"

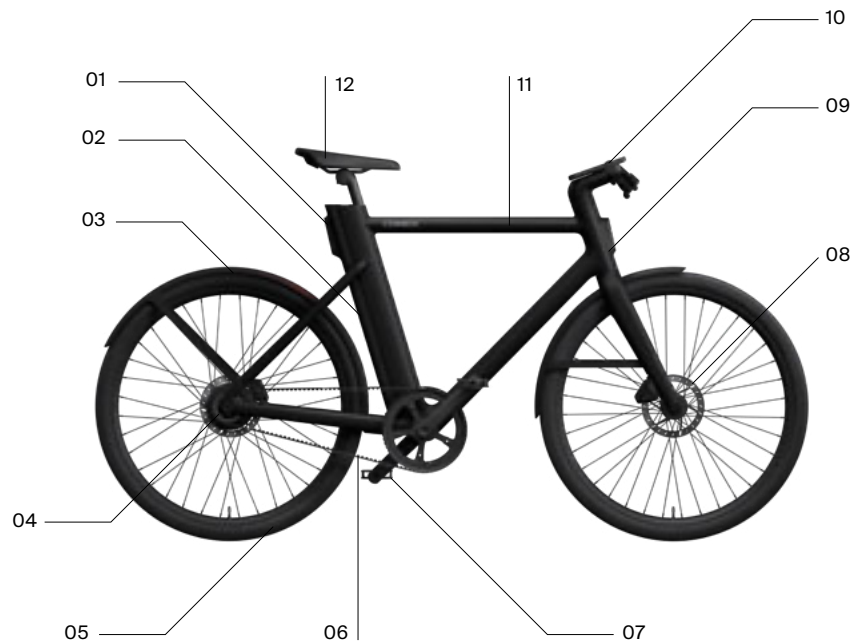

C4 ST Suitable size: 5'4" to 6'2"

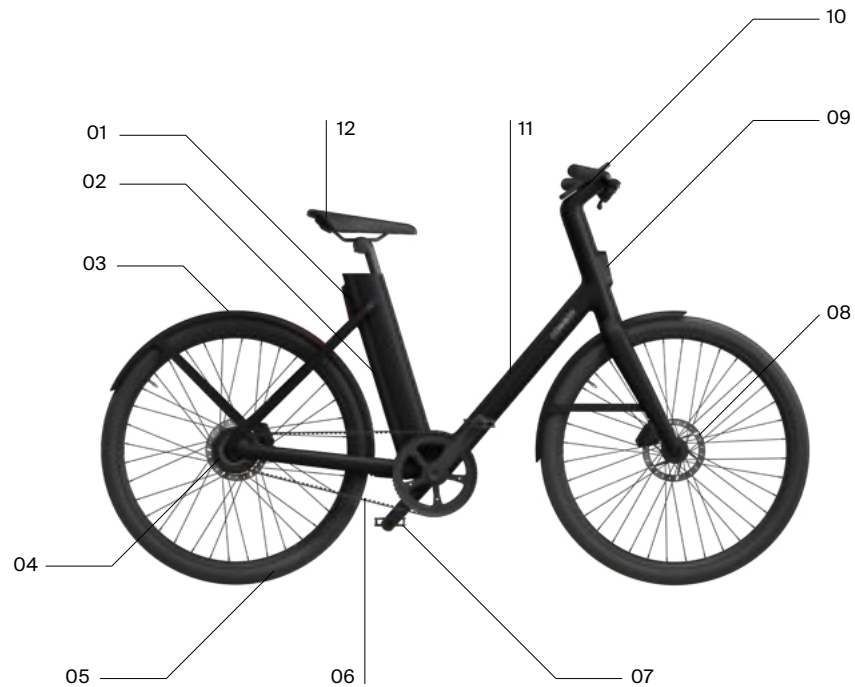

01

Handlebar

01 Check

Your bike comes with the handlebar parallel to the wheels and frame.

02 Rotate

Turn the handlebar **90 degrees clockwise** until it's at a right angle to the rest of the bike.

Warning: the front brake disc marked in the diagram must end up on the **left side** of the wheel. If you see the disc brake is sitting incorrectly on the right-hand side, turn the fork in the counter-clockwise direction to rectify.

03 Secure

Use Allen key 3 to tighten the two screws securely as shown. This will keep your handlebar in place. Be sure to insert the short end of the Allen key for the greatest purchase when tightening, then test it to make sure it's fully secure by blocking the front wheel between your legs and trying to move the handlebar from left to right.

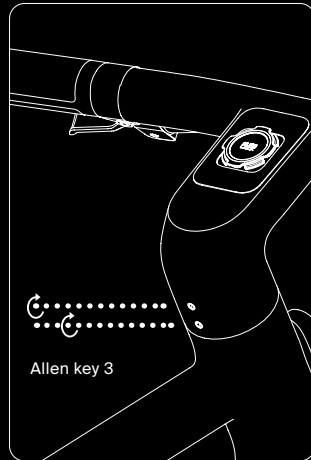
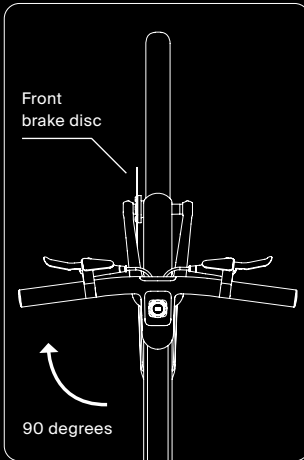
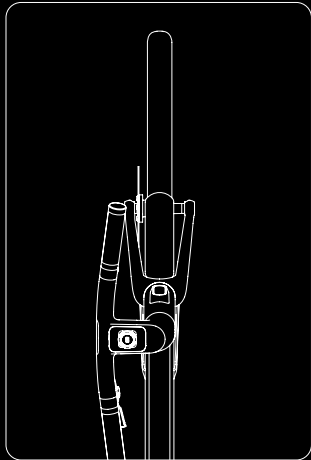

02

Brakes

01 Loosen

When you ride, the brake levers should be fixed on the handlebar at a 45 degree angle from the ground. Check the position of your brake levers. If they are already at a 45 degree angle, they do not need adjusting. If the brake levers are pointed down towards the ground as in the illustration below, then first loosen the screw under each brake using Allen key 5 as shown.

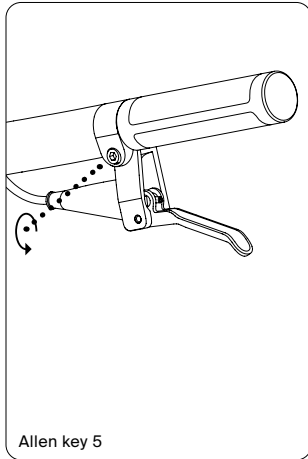

02 Turn up

Turn the brake handles and grips up until the brake handles are at a 45 degree angle. Hold them in place.

For C4 ST, just as you can set your brake handle position, you can also rotate the ergonomic grip to fit your hands perfectly.

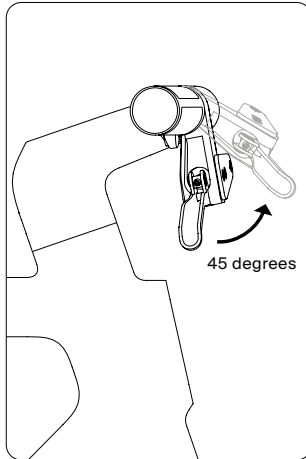

03 Tighten

Tighten the screw as shown using Allen key 5. Make sure it's nice and tight so that the brake levers don't rotate, taking care to not overtighten.

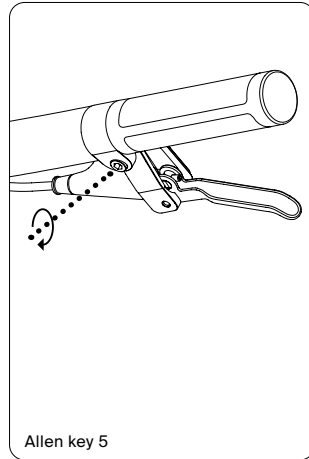

03

Pedals

01 Know right from left

The right and left pedals are different. You can tell them apart by their position in the box and the three small grooves on the left pedal axle only. You will also find the stamped 'R' and 'L' on the end of the axle.

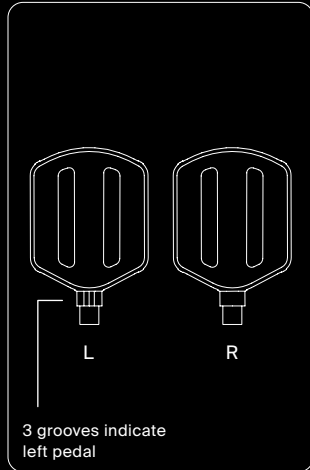

02 Screw in

Take the right pedal and screw it in **clockwise** as far as you can by hand. It should screw in easily. If it doesn't, stop right away as you may be damaging the screw. Make sure the pedal is properly aligned before trying again.

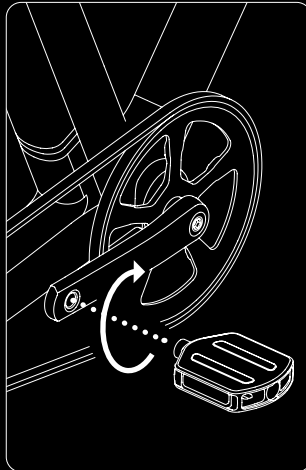

03 Tighten up

Insert the shorter end of Allen key 6 into the screw head on the side of the pedal closest to the frame. Tighten as firmly as possible.

Repeat these steps for the left pedal, screwing **counter-clockwise** this time.

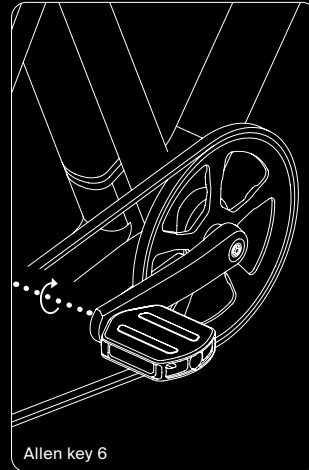

04

Saddle

01 Find the right position

Let's work out your perfect saddle height. Sit on the bike and move the pedal around with your foot until it's closest to the ground in the 6 o'clock position. You'll know the seat is the right height when your leg is just slightly bent, as shown in the diagram.

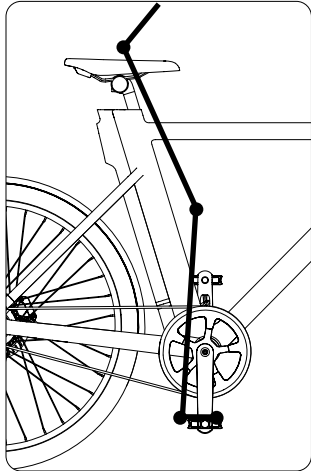

02 Take out the battery

To change the saddle height, you'll first need to take out the battery using one of the battery keys provided.

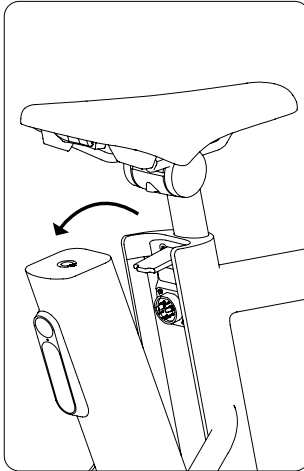

03 Adjust the height

Loosen the saddle by turning the Butterfly Allen key 4 in the two holes as shown, then raise or lower the saddle to your desired height.

Warning: do not raise the saddle higher than the depth warning mark indicated on the seat post as the seat-post and saddle could break. Use the Butterfly Allen key again to secure it in place.

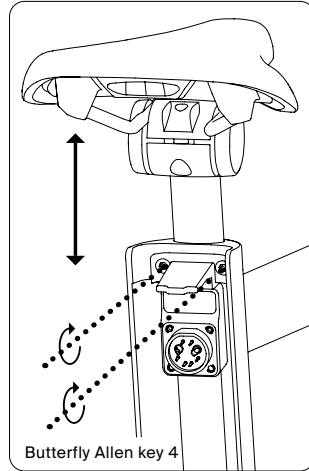

05

Wireless phone charging

01 Dock your phone

With the Cowboy app about to be front and center, put the Quad Lock case on your phone. Position your phone at 45 degrees and slot the phone over the mount, making sure the two are aligned. Rotate the phone so it's upright at 0 degrees as shown. It should click right into place. Always check your phone is secured before you ride.

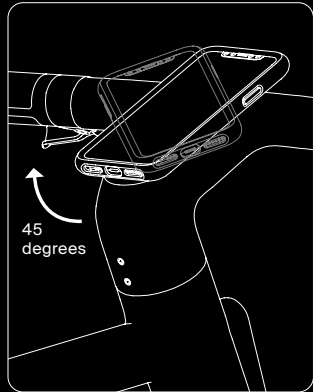

02 Charge up

If your phone supports wireless charging, it will charge automatically when docked with the bike turned on. For the best result, enable fast charging in your phone's settings.

Warning: Do not keep metal objects (such as coins and credit cards) between the phone and the charger as you risk being burned. There is risk of potential medical device interference. If you have an electrical device such as a pacemaker, consult a physician before using wireless charging. Do not attempt to mount anything heavier than a smartphone as the attachment could break and result in the damage of your device.

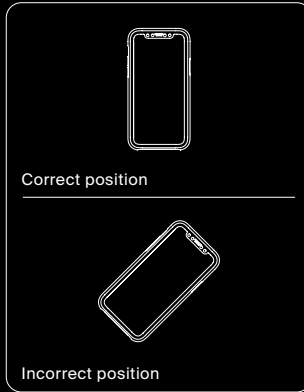

03 Undock your phone

To undock your phone, simply turn it back through 45 degrees and remove it from the mount. Be careful not to leave your phone unattended on the bike as anyone can detach it.

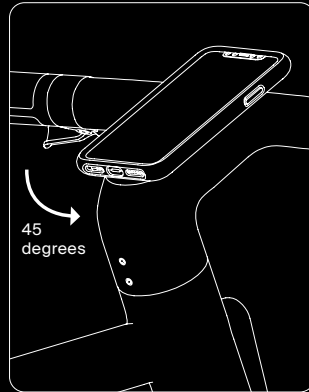



06

Know your bike

Safety lights

The integrated taillight flashes when you brake to let those behind you know you're slowing down.

A handy battery

Roam far and wide with up to 43 miles (70km) range. Your battery is easily removable and recharges to 100% capacity in 3.5 hours.

Motor and belt drive

250W of power to assist you up to 20mph. No oily chain to mess with, no gears to bother with—just one smooth ride.

Sensors

With sensors embedded in the bike, there's constant dialogue with the app and you for an informed, safe and worry-free ride.

Brakes

Hydraulic disc brakes offer total stopping power the second you make contact.

Tires

1.85-inch custom tires with a flexible grip and a puncture protection layer.

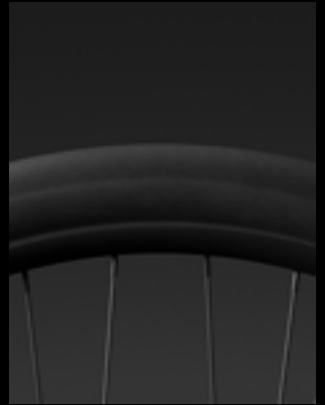
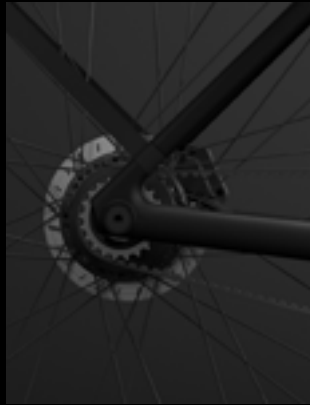

Know your bike

Now that your bike's assembled, let's take a look at some of the quintessential Cowboy features. From stem to sprocket, every detail of the Cowboy 4 is crafted to offer an unparalleled riding experience.



01 Taillight

The integrated taillight flashes when you brake to let those behind you know you're slowing down.

02 Removable battery

The battery has up to 43 miles of battery autonomy depending on the road, load, weather, and other conditions, and weighs just 5 lbs.

03 Rear hub motor

250W of power to assist you up to 20mph. Ride like you always do, but faster.

04 Gates carbon belt

Hassle-free maintenance and no oily chain to deal with.

05 Sensors

Sensors in the bike frame detect a fall and alert your emergency contacts via the app.

08 LED display

Eight LEDs in the cockpit display the bike's battery level.

07 Headlight

Iconic Cowboy lights help others see you on the road.

06 Tires

All-rounder tires with a flexible grip and a puncture-resistant layer.

Did you know?

Your Cowboy 4 has over 90 custom-designed parts. Every detail adds to the iconic Cowboy look and sets a new performance standard. Once you connect the app, you'll get to know your new bike and all that it can do.



The connected ride

From mapping the best routes to keeping you informed of the essentials powering your bike, the app is your key to a smarter, more mindful ride.

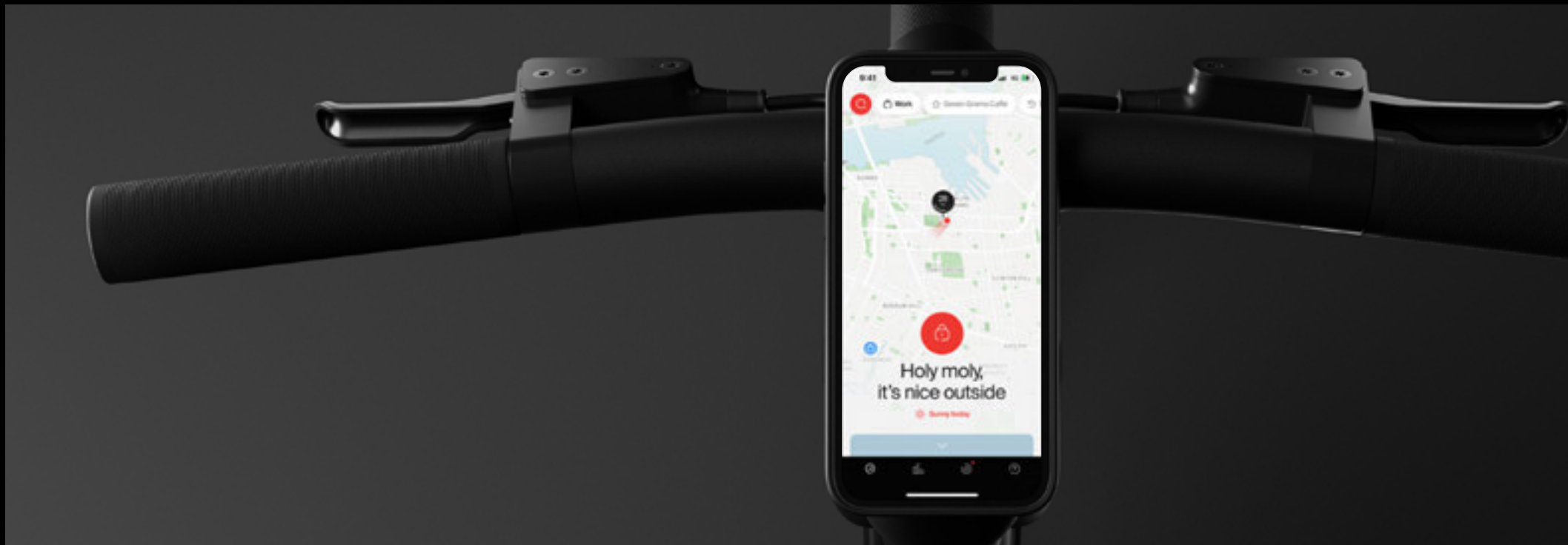

07

The app

Pair the app

- 01 Download the iPhone or Android Cowboy app
- 02 Create your Cowboy account
- 03 Pair your bike in the app
- 04 Turn on your bike and ride

Your road companion

The Cowboy app is your daily companion on the road. It's always looking ahead, keeping a check on things like weather conditions while having a little fun along the way.

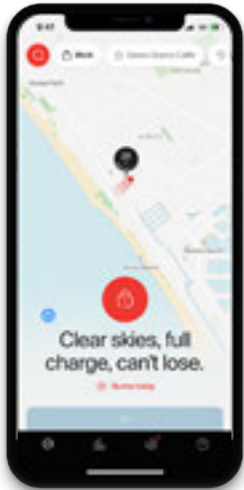

Your ride dashboard

Monitor your speed and check your stats at a glance or choose to go deep into your trip history.

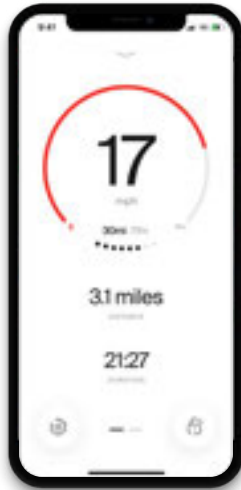

Route planning

Beat traffic by mapping the quickest route or find a healthier way with real-time air quality mapping in your area.

Warning: keep your attention on the road and your surroundings at all times. Follow regional or state laws regarding the use of smartphones while driving a vehicle, and only use the Cowboy app or other apps suitable for use while operating a vehicle.



Trip highlights

With sensors embedded in your bike, you can track all your activities – moving time, speed, calories burned, and more. You'll even earn badges as you unlock new milestones.

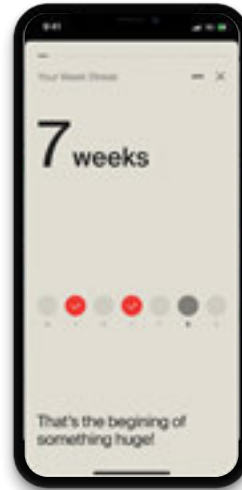

Find my bike

With GPS tracking, see the location of your bike anytime and track its live position in the app.

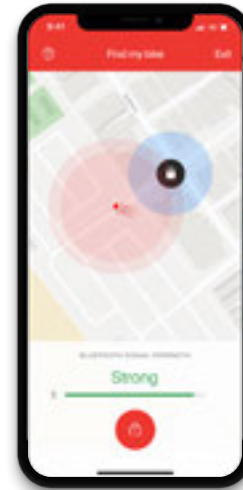

A network of support

Connect with our support team directly through the app, whenever you need a fix or have any questions along your ride.

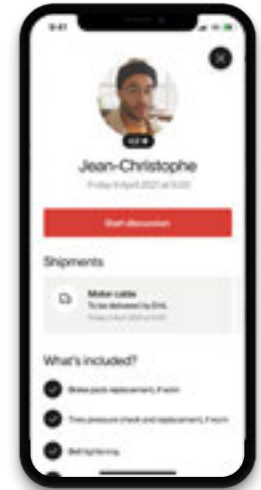



08

Accessories

You have your bike and you've made it your own. If you ordered any of the Cowboy bespoke accessories, follow the tips on the page opposite.

Rear rack

Your rear rack has a weight limit of 50.7 lbs. Be mindful when you are steering and braking that a loaded rack affects the bike's weight distribution and stability. You may need to compensate with the way you cycle. Make sure you stay visible and do not mount accessories that block the taillight.

Warning: Please see Cargo on page 40 for safety information related to carrying cargo.

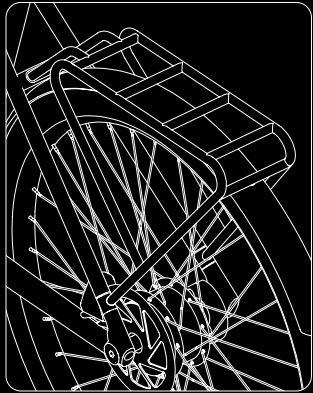

Kickstand

Simply use your foot to extend the kickstand when you want your bike to stand upright. Be careful of slippage when standing the bike on a wet surface.

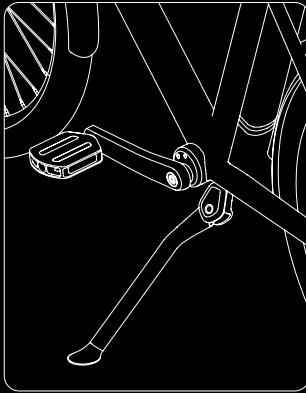

9

You're ready to ride. But first...

Before every ride

1. Make sure that the battery is fully clicked into the frame.
2. We recommend always riding with your bike lights turned on for maximum visibility on the road. Check that both sets of lights are working before setting off.
3. Tires deflate during shipping and storage. Inflate them to a pressure of 2.5 bars (36.3 psi) for heavier payload and less for a lighter payload. We don't recommend a tire pressure below 1.5 bars (21.8psi) or at the max pressure of 4 bars (58 psi) as this will make your ride less comfortable.
4. Squeeze the brakes to check they are working perfectly.
5. Check the belt tension by pressing firmly down in the middle of the belt with your index finger. The deflection of the belt should be between 0.2 and 0.4 inches. Do not lubricate the belt. Refer to Gates™ carbon drive manual for more info: gatescarbondrive.com/resources/manuals-and-tech
6. Wear the correct protective gear. Always wear a helmet and be visible on the roads.

7. Remember that you will need to brake sooner and more smoothly in wet conditions as stopping distances increase.
8. Adjust your total payload to stay within the 88lb (140kg) limits of your bike (including accessories, rider and the cargo). Note that the rear rack has a weight limit of 50.7 lbs (23kg).

Before your first ride

Get informed

In many ways, riding your new bike with pedal assistance is similar to riding a conventional bike. You should know the general rules of the road and techniques for riding a bicycle safely on the road and anywhere else you will be riding. This includes basics such as balancing, using hand levers for braking, managing various road conditions, and signaling your intentions to others. See, for example, [Kids and Bicycle Safety \(nhtsa.gov\)](#) (applicable to riders of all ages) and other resources at [Bicycle Safety | NHTSA](#). If you are not familiar with these types of skills, your local bike shop or public safety department may offer classes or have recommendations for local resources.

Charge up

Charge your bike battery fully before your first ride.

When docking your phone in the cockpit, always use the Quad Lock mount provided and check the phone is securely in place. Note that wireless charging will likely not work if you have a metal phone case. Your bike can interrupt wireless charging if it senses your phone is overheating.

Take it slow

Get used to your new bike in a safe area with minimal traffic.

When mounting your bike, make sure not to step on the pedals before you sit on the saddle and get a firm grip on the handlebar and brake levers. It is recommended to start with one pedal in the lowest position.

To maximize braking power and avoid squeaking noises you will need to bed in the brakes. To do so, come to a complete stop 30-40 times on your new bike in a practice area.

Follow local regulations

Your state and possibly your local area will have rules and regulations for bike use and may have specific rules for bikes with pedal assistance.

A summary of state laws for electric and pedal assist bikes can be found online at [State by State Electric Bike Laws | People for Bikes](#). Check with your local government for additional rules in your area. Regulations can change so make sure to stay up to date.

Brake with care

The bike is equipped with hydraulic disc brakes. The left-hand lever activates the front brake while the right-hand lever activates the rear brake.

Many conditions affect braking, including weight, speed, and road conditions. Practice in a safe area first and plan ahead as you ride.

Under wet conditions, stopping distances may increase as braking effect is reduced. Extra caution is required.

After heavy use, the brake discs may be hot. Avoid touching them until they cool.

Ride safely

The Cowboy bike differs from pedal bikes you may have had experience with as the weight distribution is centered over the rear wheel, where the motor sits. Bear in mind the bike may feel rear-heavy when loading, parking or lifting the bike.

Do not hang bags or heavy objects on the handlebar as this may interfere with your ability to steer accurately and safely. Note that your bike has been designed for a total maximum load of 309 lbs (140kg), including the bike, accessories, rider, and cargo.

Avoid wearing loose clothes such as skirts and wide-legged pants. Make sure you secure any loose straps that can get caught in the wheels and cause accidents. You may wish to use pant clips.

Cargo

Carrying cargo can affect the bike's weight distribution and handling, including stability and stopping distance. Be mindful of this when you are steering and braking. You may need to compensate with the way you cycle.

Rear rack

Do not use the rear rack as a passenger seat or child carrier. Make sure you always stay visible and do not mount accessories that block the rear light. The rack is not designed to tow a trailer; attempting to use it in this fashion may result in an accident.

Bicycle trailer

If you wish to attach a bicycle trailer, speak to our Customer Success team via the app or online to find a specific adaptor. Please note that the rear rack is not designed to tow a trailer.

Third-party accessories

If you wish to use third-party accessories with your bike (such as a luggage carrier), we recommend that you check compatibility with the accessory's manufacturer before purchasing.

Passenger safety

The Cowboy 4 and 4 ST are designed for adult riders. There are third-party child seats and trailers that could be attached to these models to transport a child; however, carrying or towing a child on a bike involves risks – consult the accessory manufacturer regarding compatibility and potential risks to you and your child. Check with your pediatrician and see online resources such as the American Academy of Pediatrics (AAP) [Baby On Board: Keeping Safe on a Bike - HealthyChildren.org](#) before deciding whether or how to transport a child with a bike.

Any questions? Speak to us.



10

Battery care and safety

Range

Your battery will give you power for up to 43.5 miles (70km). Note that this is a maximum value and exact range always depends on the riding conditions. A range of 43.5 miles is typically only achievable with a new battery, minimal wind, a consistent speed on a good asphalt road, a total passenger and cargo load of 165 lbs (75kg) and an outside temperature of 68°F.

The following factors can impact range:

- **Temperature.** A colder environment drains the battery faster.
- **Riding behavior.** Frequent acceleration and deceleration requires more power than maintaining a single speed.
- **Payload.** A heavy payload will drain the battery more quickly.
- **Time between each trip.** The bike is always on standby and continuously consumes a small amount of power. If you don't use your bike for a few days in a row, the remaining battery capacity will be slightly lower and your range will be impacted.
- **Battery age.** Your range is expected to decrease over time as your battery ages.

Protect your source of power

To reduce the risk of fire, explosion, skin irritation, serious injury, or death, follow these battery charging and care instructions. Warning: if your bike is involved in a collision or accident of any kind, make sure to contact our Customer Service team via the app to evaluate the need for a battery check-up.

Over time, your battery gathers data to improve the accuracy of its estimations any time you discharge the battery when the last LED is blinking (7% power remaining) and you charge it fully afterward. It's normal for the battery percentage displayed to be inaccurate for your first few rides.

Charge the battery indoors between 50°F and 77°F on a heat-resistant, non-flammable surface using the charger from the accessories box.

Do not expose the battery or charger to full sun, moisture, or water during charging. Keep the battery away from fire and heat. We recommend you charge the battery only when you are able to monitor it (for example, while you are awake, close by, and able to check on it periodically). Choose a dry room fitted with smoke detectors and/or sprinklers as the location for charging. Do not ride in the rain without the battery inserted in order to keep the battery connectors clean and dry.

Make sure that the battery is in sound condition with no corrosion, cracking, or other damage before using it or charging it. Do not open, disassemble, or crush the battery. Do not use a defective battery or charger.

Warning: Keep the battery and charger out of the reach of children. Use of any battery but a genuine Cowboy battery presents a serious safety hazard. New batteries can be ordered with us directly. Dispose of used batteries at your local recycling center. The battery pack must not be stored below -4°F or above 140°F; we recommend storing at room temperature. Never place the battery pack near a source of direct heat, such as heater or oven. Be careful not to drop the battery pack and do not attempt to open it. If you have any doubts, contact Customer Service for more information.

Long live your battery

Battery life in general is described as the number of cycles it takes to arrive at 60% of the original battery capacity in ideal conditions. For Cowboy this would be 500 cycles. Note that lithium ion batteries such as yours have no memory effect; therefore, we recommend charging your battery after every ride.

To maximize the lifetime of your battery:

- Avoid leaving it fully discharged for prolonged periods.
- If you plan on not using your bike for longer periods of time, remove the battery from the bike, store it in a dry environment at room temperature (between 50°F and 77°F) and keep it partially charged, ideally between 20% and 80%.
- The battery pack should be stored at room temperature. Avoid exposing the battery pack to direct sunlight on warm summer days.
- Make sure that the battery gets a full discharge-to-charge cycle at least once every two months.

11

Maintain your bike

Servicing & parts

We recommend servicing the bike once a year or every 600 miles, whichever comes first.

As with all mechanical products, this bike is subject to wear and fatigue. Different materials and components may react to this wear in different ways.

Warning: If the design life of a component is exceeded, it may suddenly fail, and possibly cause injuries to the rider. Any crack or change in coloring in highly stressed areas indicates that the component should be replaced.

Warning: Do not try to open or access any part of the electrical system of the bike. Attempting to do so risks injury and permanent damage to the bike.

Intended use

You run the risk of an accident if you modify or tune your bike yourself. Modifications made to your bike can void the warranty and may result in the bike no longer being approved for use on public roads.

You should not perform any maintenance work on your bike without extensive knowledge. If you have any doubts or questions, contact us via the app or the chat on the website.

Always use Cowboy genuine spare parts.

Warning: Use of any battery other than the genuine Cowboy product risks explosion. New batteries can be ordered with us directly. Dispose of used batteries at your local recycling center.

Cleaning

Always remove the battery before performing any maintenance or cleaning.

Use a moist piece of cloth for the frame. We suggest using water to clean the saddle. Bike cleaning products can be used to wipe down the frame. Do not steam clean, high pressure clean, or use a water hose to clean your bike or its battery.

Brake system

Brake pads are an important part of your bike and ensure that you can always ride safely. It is recommended that you check them every 600 miles, or as soon as you feel decreased braking power or hear a creaking noise. Your brake pads have a built-in wear indicator. When the surface is worn away so the small blue circle is visible, it's time for a replacement set. The brake pads used on Cowboy bikes are the SunRace UWD5 / Tektro F10XS. Other compatible brake pads include:

- Tektro F10BS
- Shimano K03S

The brake system is a hydraulic system, and can only be used with mineral oil. Should the brake system oil need to be topped up or replaced, you should only use mineral oil.

Tires

Your tires will naturally wear over time and need replacing. When the tire is worn down such that the inner layer becomes visible, it's time for a fresh tire.

If you need to replace the inner tubes, you can choose any tube with a Presta valve (aka F/V) that is compatible with the following tire dimensions (there are several ways to define tire sizes):

- 42-584 / 47-584
- 27,5"x1,65"/27,5"x1,75"- 650-42/650-48

If you can't find tubes that fit those tire dimensions, you may use smaller tubes such as:

- 559-47 or 26"x1,75"

If you need to remove the wheels for any reason, re-assemble the front wheel through the axle with 10Nm of torque and the rear wheel nuts with 35Nm. Speak with us in the app or online for tutorials and guidance.

Belt drive

The drive belt system on this bike does not require lubrication. Do not lubricate the drive belt system. Lubricant will cause the belt to permanently slip, which will require replacement of the belt and degreasing of your e-bike.

Regularly inspect the belt and sprockets carefully for signs of deterioration. Make sure the belt is always kept free of any debris. It may be cleaned with water and a small amount of soap if needed. Dirt and dust hasten wear, which may cause the belt to break unexpectedly.

When the belt is worn it will need replacing. Contact us via the chat in the app or online to source a fresh belt.

Motor

For any motor-related issues, please contact us directly rather than trying to fix them yourself.

The motor is an auxiliary motor limited to 250W of power and provides assistance up to 20mph, in compliance with US regulations. Note that motor assistance will not function below 14°F or above 140°F. The motor assistance system's A-weighted emission sound pressure level at the rider's ears is less than 70 dB(A).

Built for any season

The bike is designed for high performance in all seasons, but there are certain things you can do to take care when battling the elements and to protect yourself riding by night, on wet surfaces, or venturing off-road.

- Invest in rain-proof clothing. High-visibility clothing helps you to be seen by others on the darkened road.
- Riding in the slush and snow will kick a lot of salty, dirty water onto your bike. Over time this can lead to damage from corrosion. Be sure to wipe your bike down with a damp cloth after each ride.
- Extreme seasons go harder on the tires, so routinely check for wear and tear.
- Remember, less grip on icy roads means it takes longer for the bike to come to a stop. Be mindful to apply the brakes sooner and more smoothly than you would normally.
- For optimal performance and battery life, avoid parking the bike in direct sunlight on warm days.

You're all set to ride in any weather. The seasons come and go, but we're always by your side.



12

Warranty

Return policy and limited warranty

a. Return and Refund Policy.

If you are unhappy for any reason with your purchase of a Cowboy bike and any custom accessories you purchased with it (kickstand and/or luggage rack), you have the right to return your order without giving any reason and for a full refund without costs for 30 days from receipt of these Cowboy products. To make a return, you can send an email to hello@cowboy.com stating your intent to return the product and withdraw from the contract of sale. Your email should include the order date, the date you received the product, your name, and your address. The Cowboy team will be in touch to arrange the logistics and cover the shipping costs. Please hold on to the original packaging during the return period in case you need to send the bike back to us for any reason.

Please also note that this return and full refund offer applies only to the bike and custom accessories you purchase with it (kickstand and/or luggage rack). Returns of third-party accessories including the Kryptonite Lock, Quad Lock Case, or Quad Lock Mount are only accepted if the items are unused, in their original packaging, and in a resellable condition. For these items, Cowboy will still contact you to arrange the logistics and cover any shipping costs.

b. Limited warranty.

This limited warranty gives you specific legal rights, and you may also have other rights, which vary from state to state. We warrant that during the warranty period, the products you purchase from us will be free from defects in workmanship or materials, as explained in more detail in this section below. To the extent not prohibited by law, this warranty is exclusive and in lieu of all other warranties, oral, written, statutory, express or implied. Except for the express warranties contained in this limited warranty statement and to the extent not prohibited by law, we disclaim all other warranties, express or implied, statutory or otherwise, including without limitation the warranties of merchantability, fitness for a particular purpose, title and noninfringement. To the extent such warranties cannot be disclaimed, we limit the duration and remedies of any implied warranties to the duration of this limited warranty. Some states do not allow limitations on implied warranties or how long an implied warranty lasts, so the above limitation may not apply to you.

Our responsibility for products subject to this warranty is limited to repair, replacement or refund as set forth in this warranty statement. Neither any performance or other conduct, nor any oral or written information, statement, or advice provided by us or any of our suppliers, agents, or employees will create a warranty or in any way increase the scope or duration of this limited warranty.

(i) Who may use this Warranty?

This limited warranty extends to the original purchaser of products from Cowboy, as well as any subsequent or other owner or transferee of the product. The warranty does not apply to Cowboy's Services such as the mobile app, website, or online or other services.

(ii) What does this Warranty cover?

During the Warranty Period (as defined below), this limited warranty covers defects in materials and workmanship in products purchased from Cowboy.

(iii) What does this Warranty not cover?

This limited warranty does not cover any damages due to, related to, or arising from: (1) transportation; (2) storage; (3) improper, incorrect, or negligent use, assembly, operation, or installation of

the product; (4) failure to follow the product instructions or to perform any preventative maintenance; (5) modifications or transformations of the product; (6) combinations or use with any products, materials, processes, systems or other matter not authorized in writing by Cowboy; (7) unauthorized repair or maintenance; (8) normal wear and tear and defects inherent in the normal useful life or service life of the product; or (9) external causes such as accidents, abuse, exposure to severe weather conditions, or other actions or events beyond our reasonable control. Any alterations, modifications, or other changes made by you to the products after your purchase that affect the safety, operation, or mechanics of the bike or other products void the limited warranty and are at your sole risk.

(iv) What is the period of coverage?

This limited warranty starts on the date you, as the original purchaser from Cowboy, first receive your product and lasts for two years from that date (the "Warranty Period"). During the first six months of the warranty, you do not have to prove that the defect was already present when you bought the product. After that initial six-month period,

you do have to establish that the defect was present when you bought the product. Note that the Warranty Period is not extended if we repair or replace a warranted product or re-perform a warranted service. We may change the availability of this limited warranty at our discretion, but any changes will not be retroactive.

(v) What are your remedies under this Warranty?

With respect to any products subject to this limited warranty, during the Warranty Period, we will, in our sole discretion, either repair or replace such products (or the defective part) free of charge or refund the purchase price of such products. We will also pay for shipping and handling fees to return the repaired or replacement product to you.

(vi) How do you obtain Warranty service?

To obtain service under this limited warranty, you can email us at hello@cowboy.com, or contact us within the App during the Warranty Period.

(vii) Limitation of liability.

The remedies described above are your sole and exclusive remedies and our entire obligation and liability for any

breach of this limited Warranty. Our liability will under no circumstances exceed the actual amount paid by you for the defective product that you have purchased from Cowboy, nor will we under any circumstances be liable for any loss of production, work, data, use, business, goodwill, reputation, revenue or profit, any diminution in value, costs or replacement goods or services, or any consequential, incidental, special, punitive damages or losses, whether direct or indirect.

Some states do not allow the exclusion or limitation of incidental or consequential damages, so the above limitation or exclusion might not apply to you.

(viii) What can you do in the case of a dispute with us regarding this Warranty?

The dispute resolution procedures detailed in Section 7 below apply to you if you believe that we have not performed our obligations under this limited warranty or these Terms and Conditions.

Dispute Resolution, Arbitration, and Class Action Waiver

c. Battery and Range Disclaimer.

Please note that information regarding the expected speeds and ranges of our bikes and their batteries are estimates, not guarantees. There are many factors that affect actual real-world bike speeds and battery ranges, including but not limited to the battery and motor age, temperatures, tire pressure, pedal power, wind conditions, speeds, rider and cargo weights, and terrain. Under certain conditions, battery ranges and top speeds may be different from and less than the listed estimates.

d. California Residents.

If you are a California resident, in accordance with Cal. Civ. Code §1789.3, you may report complaints to the Complaint Assistance Unit of the Division of Consumer Services of the California Department of Consumer Affairs by contacting them in writing at 1625 North Market Blvd., Suite N 112, Sacramento, CA 95834, or by telephone at (800) 952-5210 or (916) 445-1254.

a. Notice and Good Faith Informal Resolution.

Both you and Cowboy agree that each party will notify the other in writing of any dispute arising out of, in connection with, or relating to these Terms and Conditions, your use or purchase of any Cowboy products or Services, our relationship, or any other dispute you might have in any way involving Cowboy before initiating arbitration under this Section 7, so that we can try to resolve the dispute informally and individually, negotiating in good faith. The notice must be specific and individual to you and include your name, street address, telephone number, and email, as well as a brief description of the dispute, the amount of money (if any) at issue, and the specific relief sought. The notice must be signed and include the handwritten signature of, as applicable, either you or a Cowboy employee, depending on which party is providing notice. Notice sent by you to Cowboy will be sent to the following email and street addresses: hello@cowboy.com and 45 Pleasant Street Unit 1, Newburyport, 01950, MA. Notice sent by Cowboy to you will be sent to the email and street address that you provided to

Cowboy. This notice is a requirement and condition precedent to initiating any formal arbitration proceedings. If and only if we fail to reach an amicable settlement of the dispute after good faith negotiation pursuant to this provision, then you or Cowboy may commence an arbitration proceeding starting 45 calendar days after notice is received with a written demand for arbitration pursuant to Section 7 below.

b. Arbitration Agreement.

We and you acknowledge a desire to resolve fairly and quickly any and all disputes, including existing, currently pending and/or future disputes or claims, between you and us as set forth in this Section. Final, binding, and confidential arbitration before a single, neutral arbitrator will be the exclusive remedy for any "Covered Claim." A "Covered Claim" is any past, existing, currently pending and/or future claim or dispute of any kind (except a claim or dispute that by law is non-arbitrable) that has arisen or arises between you and Cowboy, and/or their respective past, present, and future parent(s), subsidiaries, affiliates, clients, officers, directors, employees, and/or independent contractors, including

but not limited to claims arising from the Services provided under these Terms and Conditions, your purchase or use of any Cowboy products, and any other agreements between you and Cowboy. A "Covered Claim" does not include claims filed in small claims court for disputes or claims within the scope of the small claims' court jurisdiction or claims for injunctive or other equitable relief to prevent the actual or threatened infringement, misappropriation, or violation of a party's copyrights, trademarks, trade secrets, patents, or other confidential or proprietary information or intellectual property rights.

c. Application.

This Section 7 applies to successor entities without the need for a formal assignment by either Cowboy and you. This Section also includes any Covered Claim brought against a third party, including but not limited to any client(s), consultant(s), and/or independent contractors of Cowboy, and this provision can be enforced by any such third party through a motion to compel arbitration as necessary. In the event that there are both arbitrable and non-arbitrable claims covered

by this Section, the arbitrable claims must be finally and fully resolved before litigation of any non-arbitrable claims can proceed.

d. Waiver of Right to Jury Trial and Class Claims.

As to any Covered Claim, both Cowboy and you waive to the maximum extent permitted by law the right to jury trial or bench trial, and the right to bring, maintain, or participate in any class, collective or representative proceeding, whether in arbitration or otherwise. Further, all Covered Claims must be brought in the individual capacity of the entity or person asserting the claim, and cannot be maintained on a class, collective, or representative basis, to the full extent permitted by applicable law. The arbitrator does not have the authority to consider, certify, or hear arbitration as a class action, collective action, or any other type of representative action.

e. Arbitration Procedures.

Arbitration will be confidential and conducted with JAMS or another arbitration provider pursuant to the JAMS Comprehensive Arbitration Rules & Procedures (the "Arbitration Rules")

in effect at the time the arbitration is filed, available at the following website: <https://www.jamsadr.com/rules-comprehensive-arbitration/>, except as expressly set forth herein or where such rules are not in compliance with applicable state or federal law. A copy of the Arbitration Rules is available for review through Cowboy by submitting a request to Cowboy or by contacting JAMS at telephone number (800) 352-5267. For claims asserted by you, you understand and agree that you will pay JAMS' claimant filing fee under the Arbitration Rules. With respect to such claims, Cowboy will pay the remaining part of the filing fees, JAMS' administrative fees for such disputes, and the fees and expenses of the arbitrator, but only to the extent required by the Arbitration Rules and applicable law. You will pay your own attorneys' fees and litigation costs associated with the arbitration, except as required by applicable state or federal law. The arbitrator must be either a former judge or a currently licensed attorney. The parties will maintain the confidential nature of the arbitration proceeding and the award, unless otherwise required by law or judicial decision. The arbitrator, and not any federal, state, local court or

government agency, will have exclusive authority to resolve any and all disputes regarding the validity, interpretation, applicability, enforceability or formation of the agreement to arbitrate pursuant to this Section, including but not limited to the arbitrability of any claims, notwithstanding anything to the contrary in the Arbitration Rules. The arbitrator will apply the Federal Rules of Evidence, and will apply the Federal Rules of Civil Procedure regarding discovery. The arbitrator can order the same individual remedies that a judge could in a court of law, including injunctive relief but only in favor of you or Cowboy and only to the extent necessary to provide the relief warranted by your or Cowboy's individual claim. The arbitrator has the authority to consider motions to dismiss and motions for summary judgment/summary adjudication. Should Cowboy or you refuse or neglect to appear for, or participate in, the arbitration hearing, the arbitrator will have the authority to decide the dispute based upon the evidence presented. Judgment on the arbitration award may be entered in any court having jurisdiction thereof. This Section 7 is governed by and enforceable under the Federal Arbitration Act ("FAA"), this Section 7

will be interpreted under the FAA, and both Cowboy and you agree that they are engaged in interstate commerce as part of the business of the Cowboy's business. Section 7 can be modified only by a writing both signed by Cowboy and you, stating the intent to revoke or modify this Section 7.

f. Severability.

If any provision in this Section 7 is adjudged to be void or otherwise unenforceable by a court of competent jurisdiction, in whole or in part, such adjudication will not affect the validity of the remainder of the agreement to arbitrate. Notwithstanding the foregoing, if a court of competent jurisdiction holds or rules that the provision concerning the waiver of a representative and/or collective action is not enforceable as to one or more claims, only claims that the court finds can be arbitrated on an individual basis will be arbitrable under this Section 7 and any remaining Covered Claims must be pursued in court but only after completion of arbitration on the arbitrable claims.

g. Express Class and Jury Waiver. Cowboy and you knowingly and voluntarily waive for any Covered Claim

the right to class, representative, consolidated, and collective procedures and the right to trial by jury or judge, to the fullest extent permitted by applicable law. Cowboy and you acknowledge and agree that each has carefully read this Section 7 and the Terms and Conditions, understand them, and agree to them.

The product: bicycle with electric pedal assistance.

Model: Cowboy 4 and 4 ST are in compliance with directives 2006/42/EU, 2011/65/EU, 2014/53/EU, 2014/30/EU.

To see the full EC declaration of conformity, visit cowboy.com/pages/downloads



Community

Join the streets of Cowboy for a street level perspective in the living city.

Share your ride #cowboybike
Follow us @cowboy_bikes



