



Sewing Machine Presser Foot Set

— Set of 32 pcs. —

The Ultimate
USER GUIDE





SEWING MACHINE PRESSER FOOT SET THE ULTIMATE USER GUIDE

What? How? It's all here. Madam Sew explains all 32 feet in detail.

Congratulations on your purchase of this box full of very handy presser feet. The easy to store container comes with handy mini guide for the feet and you can easily identify each foot by the clear numbering. This manual details each foot and we have included the position number in the title to make things super easy for you.

All these different presser feet may appear intimidating at first, with the help of your Madam Sew Ultimate User Guide's descriptions, links to videos and blog posts in this document you will learn to use all your new presser feet in no time. You are going to have so much fun creating and learning new techniques for each of these presser feet.

We love seeing what you create!

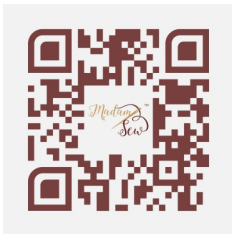

You can subscribe to this list right here:

<https://madamsew.com//presser-foot-set-updates>

(click the link or scan QR-code to subscribe to emails about manual updates).



Share your photos on Instagram with the hashtag **#Madamsew32**





IMPORTANT NOTE ON OPENING THE BOX

Please pay attention when opening the box. It should go gently. When you feel you have pull hard to open the clips, then put the box down and start over.

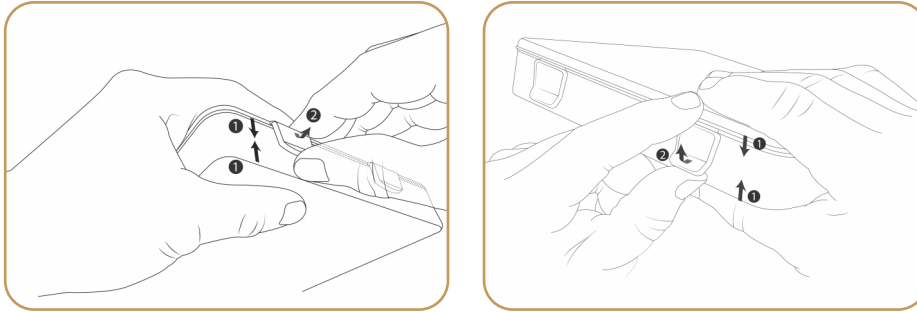

You can also put the set on a table and open it like this:

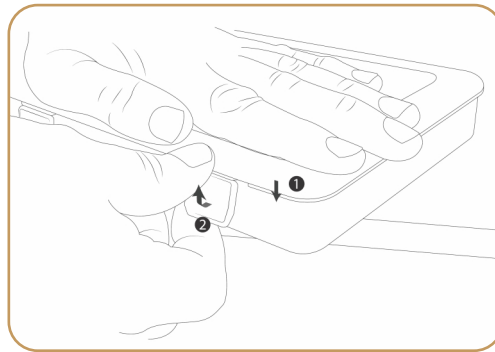

How to use this manual?



You have the choice of using the manual online or printing it out for convenience.

For those reading digitally all the links to blog posts or video will work straight from the document. Just give them a click and you will be taken straight to the information you want.

If you printed this manual you have the option to use a mobile device to scan the QR-codes that go with every link to go to the content you want to see or read. We have a simple blog post explaining how to do this if you need some assistance. You can read more at www.....

To be able to scan QR-codes with your mobile device you will have to install a QR-code scanner. There are a lot of free apps available that you can install on your device. A very good one, that is available for both iOS (iPhone/iPad) and android (most other mobile devices) is QR Code Reader. Go to www.scan.me/download on your mobile device to download it to your device.



CONTENTS

Important note on opening the box	01
How to use this manual?	01
Updates to this manual	01
I. What is in the box?	03
II. How to attach the feet to your machine	04
Your machine uses snap-on presser feet	04
Bonus Low Shank Snap on Adapter	05
Attaching the screw on feet in this set	06
Bernina adapter - Optional Extra	07
III. Description of the different feet	08
Invisible Zipper Foot (1)	08
Applique Foot (2)	09
Satin Stitch Foot (3)	09
Open Toe Foot (4)	10
Cording Foot (5)	10
Straight Stitch Foot (6)	11
Roller Foot (7)	11
Blind Stitch Foot/Blind Hem Foot (8)	12
Braiding Foot or Couching Foot or Cording Foot (9)	12
1/4 " Quilting Foot (10)	14
Beading Foot or Pearl Piping Foot (11)	14
Standard Zig-Zag Foot (12)	15
Non-Stick Foot (13)	15
Darning Foot (14)	16
Piping or Double Welting Foot (15)	17
5/9-Groove Pintuck Foot (16 & 22)	17
1/4 " Quilting Foot with guide (17)	18
Gathering Foot or Shirring Foot (18)	19
Knit Foot or Tricot Foot (19)	20
Adjustable Zipper Foot (20)	21
Fringe Foot or Looper Foot (21)	22
5-Groove Pintuck Foot (22)	23
Darning Foot 2 (23)	23
Stitch Guide Foot or Presser Foot with ruler (24)	23
5/7 Hole Cording Foot (25 & 26)	24
Edge Joining Foot or Stitch-in-the-Ditch Foot (27)	25
Overcast Foot (28)	26
Open Toe Foot (29)	26
Rolled Hem Foot and Flat Hem Foot (30 & 31)	27
Adjustable Bias Binding Foot (32)	28
References	29





I. WHAT IS IN THE BOX?



To help you get started as soon as possible in addition to the feet themselves you also receive a 12 page mini booklet explaining each foot and how they can be used. Each foot is numbered on the insert, in the graphic above and throughout the manual to keep things simple.

All Madam Sew videos for the 32 Piece set will include the position of the foot within the box as a guide.

II. HOW TO ATTACH THE FEET TO YOUR MACHINE

Your machine uses snap-on presser feet

Removing a presser foot:

Raise both the needle and the presser foot lever.

The way to remove the presser foot depends on the brand of machine you have. Sometimes it snaps off, but with most machines you have to push a button or lever on the presser foot holder. Consult your machine's user manual to find the way to remove the presser foot.

Attaching a presser foot:

Place the bar of the presser foot to align under the holder (2). Gently lower the presser foot lever so the presser foot bar (3) slides into the shank (2) in the presser foot holder (1). You may have to try a couple of times before it snaps in. If your presser foot holder has a lever or button for release, it may be necessary to pull/press it to facilitate snap-on.

Remember to be gentle with this process, no forcing is needed when the bar is correctly aligned.

The presser foot holder can look different on your machine, this picture is from a Brother sewing machine.

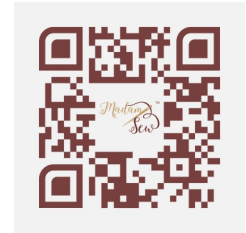

VIDEO DEMO: [Changing Your Sewing Machine Feet](#)

(click to view or scan the QR-code with your phone or tablet)

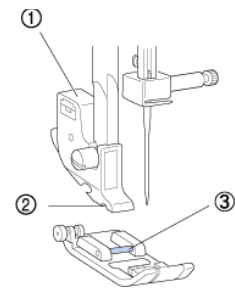

II. HOW TO ATTACH THE FEET TO YOUR MACHINE

Bonus Low Shank Snap on Adapter

If you have a low shank machine but no snap-on feet the Bonus adapter is for you. Use the bonus low shank snap on adapter to give the ability to use all the feet in this collection.

The adapter is attached using a simple screw to hold it in place on the shank of your sewing machine, after removing the original foot holder. Remove the holding screw (3) with a screwdriver (1) or the multi tool supplied with your sewing machine and replace the original foot holder (2) with the Bonus Adapter.

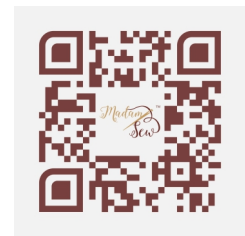
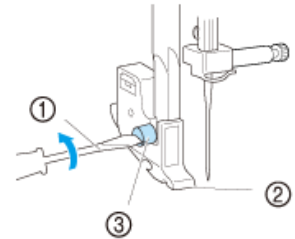

You can see this process in full in the video below.

VIDEO DEMO: [Bonus adapter - Madamsews Ultimate Presser Foot Set](#)

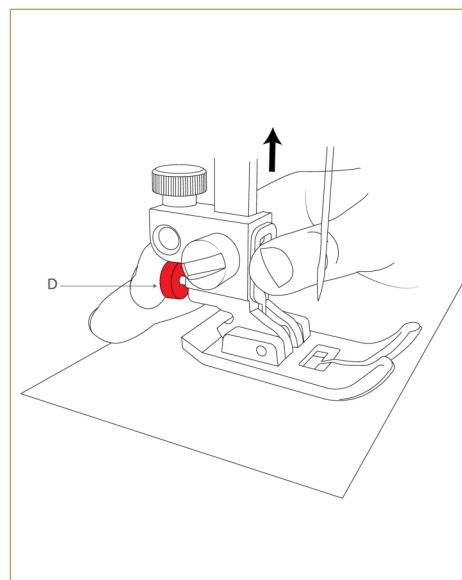
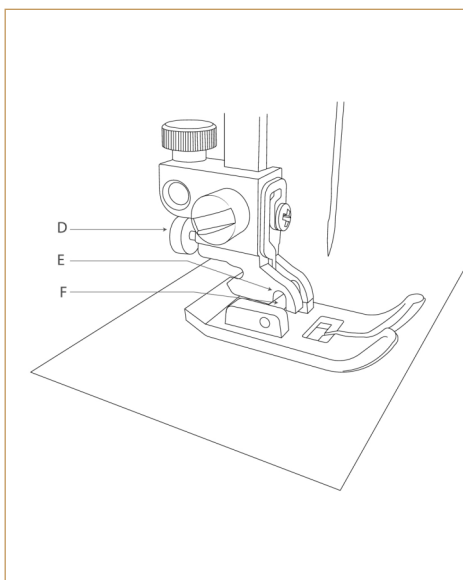
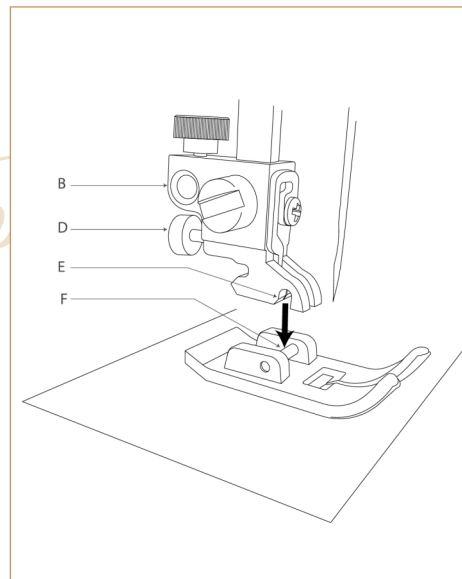
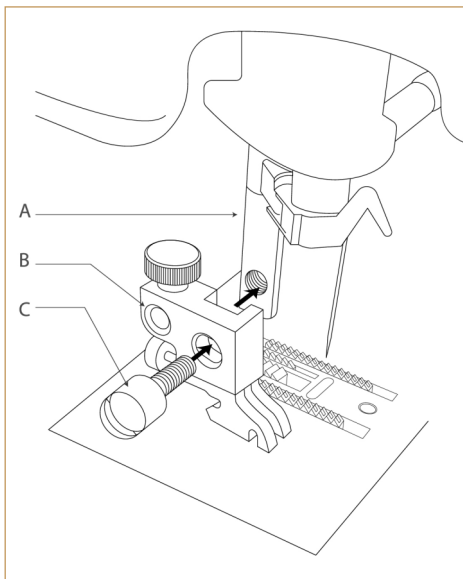

II. HOW TO ATTACH THE FEET TO YOUR MACHINE

Attaching the screw on feet in this set

To use the following feet you have to remove the presser foot holder/bonus adapter:

- 14 - darning foot
- 18 - gathering foot
- 20 - adjustable zipper foot
- 23 - darning foot

You can remove the presser foot holder/bonus adapter following the steps in the picture.

Unscrew the presser foot holder screw (thumbscrew) (3) with a screwdriver (1) and remove the presser foot holder/bonus adapter (2). The presser foot holder can look different on your machine, this picture is from a Brother sewing machine.

This is the same process as used to attach the bonus adapter. With some feet you will also need to take into account the positioning of a top arm. This is clearly demonstrated in the tutorials for those specific feet.

After removing the presser foot holder you can attach the screw on presser feet with the thumbscrew (presser foot holder screw).

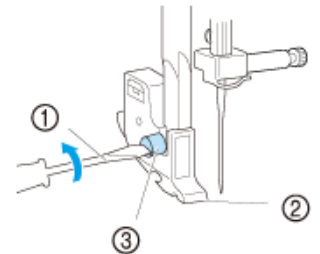

II. HOW TO ATTACH THE FEET TO YOUR MACHINE

Bernina adapter - Optional Extra

If you bought this set together with a bernina adapter you will have to attach the adapter to your machine just like you attach a Bernina presser foot.

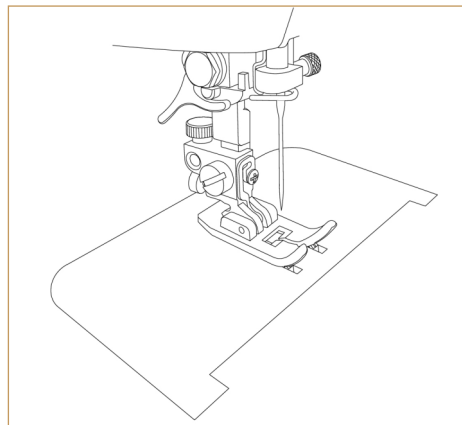
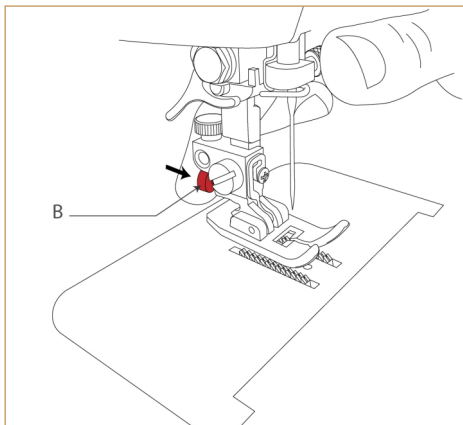
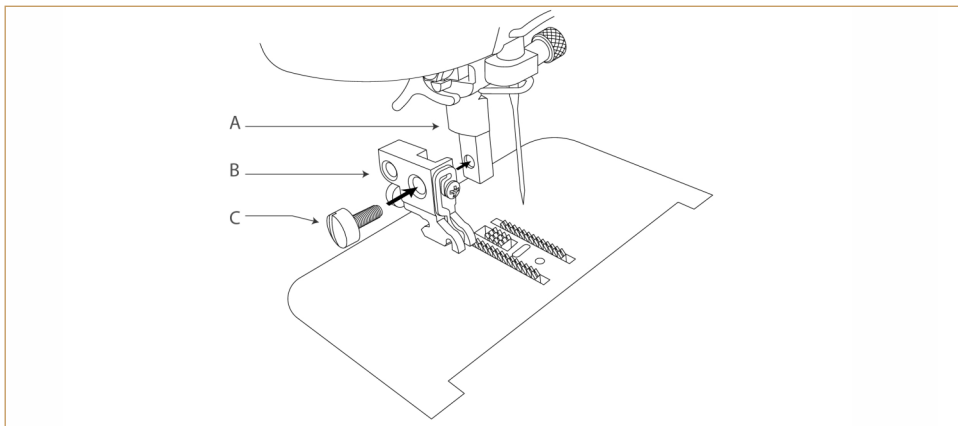
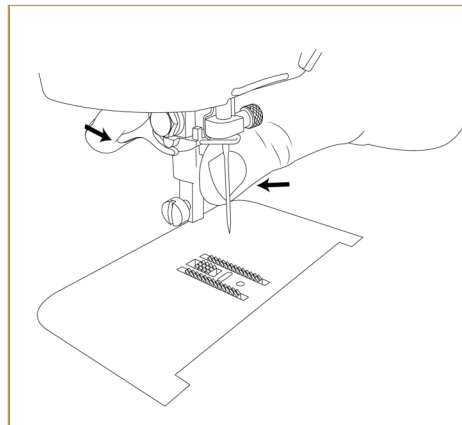
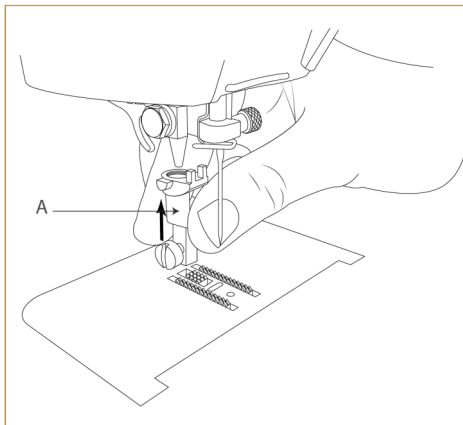

Now you can use the adjustable zipper foot, the gathering foot and the two different darning feet. To use the other feet you attach the bonus adapter to the Bernina adapter as described above.

III. DESCRIPTION OF THE DIFFERENT FEET

Invisible Zipper Foot (1)

This zipper foot makes inserting invisible zippers very easy. The grooves on the bottom of the foot hold the zipper coils in place to avoid any slipping while sewing. This provides an invisible closure on skirts, dresses and all garments and can be used on other projects, such as bags and pillows as well.

The key to this foot is understanding the basic structure. Invisible zipper feet have grooves on the underside of the foot that allow the zipper coils to slide through smoothly.

I love adding an Invisible Zipper to a garment. There is no need to be afraid of them; they are really easy to install. All you need is a Madam Sew Invisible Zipper Foot and adding an invisible zipper is a snap. You'll be an expert in no time at all.

The beauty of an invisible zipper foot is the way the coils fit perfectly into the grooves on the sole of the foot. Once in position, the machine needle glides right up to the edge of the zipper coils making for a very straight stitch. Place the fabric right side up beneath the the presser foot. Once sewn in place the zipper will be forming the seam and will have been pressed in place to the wrong side of the fabric.

- 1) Place the zipper coils in the groove, upside down, and set your machine needle in the center position.
- 2) Your fabric should be right side up with the raw edge of the fabric aligning with the edge of the zipper fabric.
- 3) Slowly, begin stitching; the foot will place the stitching very close to the zipper coils. When you reach the bottom, the foot will not allow you to sew past the zipper pull. Stop, back stitch, and remove from machine.
- 4) Repeat on the opposite side, with a new section of fabric again face up and aligning the raw edges.
- 5) Press open as you would with any regular seam.

You cannot see the zipper against the fabric when the zipper is closed.

To practice this technique, get an invisible zipper and a Madam Sew invisible zipper foot. Cut two pieces of fabric 6" longer than the zipper and 5" wide. Set your machine on the longest stitch setting and practice. Rip out, and try again. After 2-3 times, you will have it down.

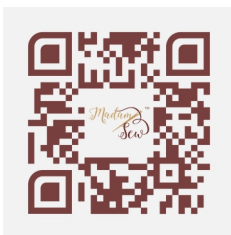

VIDEO DEMO: [How to sew in an Invisible Zipper using an invisible zipper foot](#)
(click link to view or scan the QR-code)

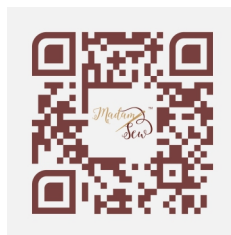

INFO PAGE: [How to Sew an Invisible Zipper in 4 Simple Steps](#) (click link to view or scan the QR-code)

III. DESCRIPTION OF THE DIFFERENT FEET

Applique Foot (2)

When it comes to appliquéing with a satin-stitch, the Madam Sew Appliqué foot is the expert: its simple design allows the fabric to feed easily over the stitches, even in the case of very dense rows of stitching.

And since the Madam Sew Appliqué foot features a clear sole, you'll have a perfect view of the stitch area at all times – a decisive advantage, especially when following outlines and corners.

Perfect for quilting, personalized bunting, and decorative makes.

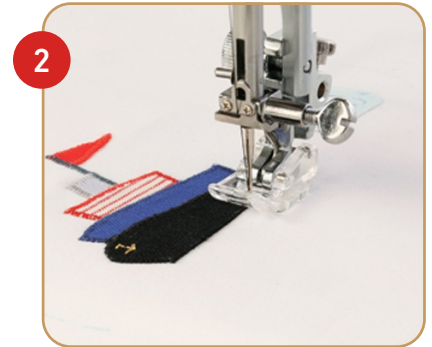

Satin Stitch Foot (3)

This foot is ideal for decorative sewing, such as applique, satin stitching and cut work. It has a grooved bottom, which allows for thread build-up and a wide needle hole opening to accommodate decorative stitches.

The cutout on the front of the presser foot will hold a narrow couching thread, making for trouble-free sewing of satin-stitching with cording. With its wide thread channel under the sole, the Madam Sew Satin Stitch foot is also ideal for sewing mini-piping, or for traditional sewing techniques.

And since the foot features a clear sole, you'll have a perfect view of the stitch area at all times – a decisive advantage, especially when following outlines and corners.

Decorative table covers, placemats and delicate embellishments for any project will be a breeze with this foot. Use a satin stitch or a zigzag stitch with very low stitch length. You can use a stabilizer at the bottom to secure your work.

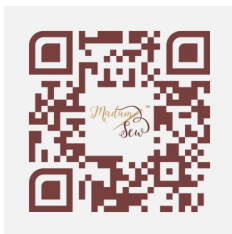
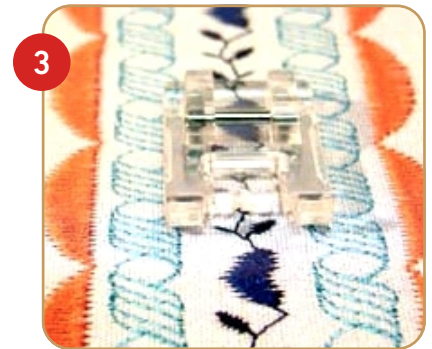

More information on stabilizers can be found [here](#) (click link to view or scan the QR-code).

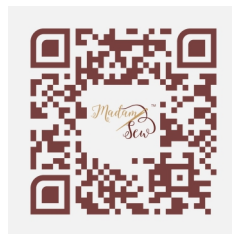

VIDEO DEMO: [How to sew using a Satin Stitch Foot](#) (click link to view or scan the QR-code)

III. DESCRIPTION OF THE DIFFERENT FEET

Open Toe Foot (4)

This foot provides an unobstructed view of your work while sewing since there is no bridge between the toes. In addition, there is a groove on the underside to allow dense decorative stitches to pass underneath without jamming. Both of these characteristics make this foot ideal for doing applique and other sewing techniques where precision sewing is important.

Great for decorative work and showing of those special stitches on your sewing machine as borders for cushion covers, table linens and more.

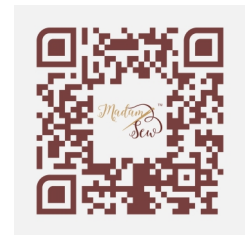

VIDEO DEMO: [How to sew using an Open Toe Embroidery Foot](#)
(click link to view or scan the QR-code)



Cording Foot (5)

Another simple to use foot from Madam Sew which can create a range of beautiful effects. Lacing the stitches around cording to secure an attractive embellishment to the front of your fabric.

Use this foot to attach decorative cords and threads. Select threads and small cords that will glide easily through the holes on the cording foot of your choice. Select the multi-step zigzag stitch and adjust it wide enough to catch the outside threads. Now that your threads are under control, you can place both hands on the fabric to guide and move through the pattern you select.

Use a selection of threads, invisible, iridescent or contrasting for a variety of effects. I have shown the basic triple zig zag, you can opt to use any of the decorative stitches to achieve the look that is perfect for your project.

Experiment and play with different cords, threads and stitches to learn how to get the most from this presser foot.

Stunning decorative effects for sleeves, bags bedding and more.

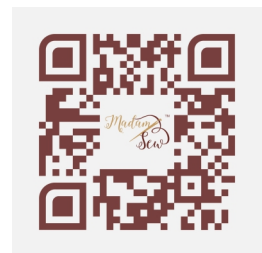

VIDEO DEMO: [How To Use A Cording Foot](#)
(click link to view or scan the QR-code)

III. DESCRIPTION OF THE DIFFERENT FEET

Straight Stitch Foot (6)

This foot is especially useful on lightweight fabric and tackling multiple layers. It is designed to glide evenly over fabric so you avoid puckering. The built in measuring gauge on the right toe is great for accurate topstitching and the toes are a great edge stitching guide.

The larger left hand toe allows to easily tackle multiple layers of fabric by feeding them gently into the needle.

Multi layered skirts, bedding and flounces can be created with ease using the Madam Sew Straight Stitch foot.



Roller Foot (7)

The Madam Sew roller foot makes sewing difficult fabrics such as leather, suede, oilcloth and vinyl a breeze. This foot is a very clever little invention in the presser foot arsenal of the home sewer.

This foot is aptly named, and it is generally obvious to anyone looking at it what it is, unlike some presser feet, one can see what it is, but what does it do?

This marvelous tool takes the frustration out of sewing slippery fabrics, which in addition to leather, suede, and vinyl, can include chiffon, organza and even velvet.

The foot has one large roller on the front of the foot and two smaller ones on the underside of the foot, which help to stabilize slippery fabrics. This little jewel provides traction holding the fabric in place as the feed dogs feed the fabric through the machine, slippery fabrics are held securely in place and no longer slide around, or stick to the throat plate, allowing you to sew evenly as you work.

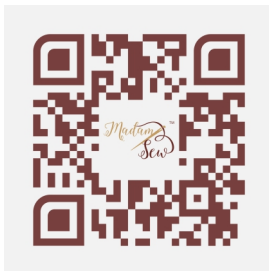

BLOG POST: [Accessories We Love: The Roller Foot For Velvet & More](#)

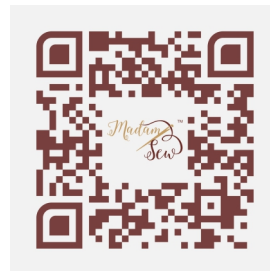

VIDEO DEMO: [How to sew using a Roller Foot](#)
(click link to view or scan the QR-code)

III. DESCRIPTION OF THE DIFFERENT FEET

Blind Stitch Foot/Blind Hem Foot (8)

Use this foot for precise stitch placement on blind-hems. The procedure for creating a blind hem with this presser foot is clearly explained in the video demo.

Traditionally used to hem skirts, shirts and trousers the technique can appear tricky at first as there is a lot of folding and flipping involved. Once you have practiced the technique it will become a firm favourite, as will the Madam Sew Blind hem foot.

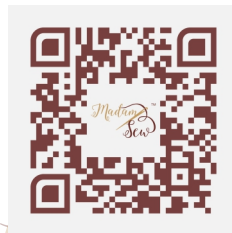
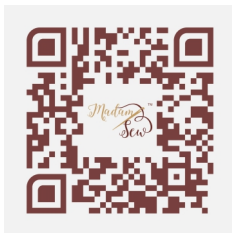

VIDEO DEMO: [How to Use a Blind Hem Foot](#)
(click link to view or scan the QR-code)

VIDEO DEMO: [How To Blind Hem Trousers](#)
(click link to view or scan the QR-code)

Braiding Foot or Couching Foot or Cording Foot (9)

The braiding foot is one of many types of feet used in couching, which is a form of decorative embellishment, where a length of braid, cord, piping, ribbon, thread, trim or yarn is couched or stitched over to attach it to a fabric project. Through Madam Sew, you might discover a wealth of new techniques or styles ;-).

The foot has a hole in the top of the foot, allowing the braid to be threaded from the top of the foot and passed under the foot. The foot is adjustable for the size of the braid, having an adjustable guide that is moved to accommodate the width of the braid by loosening a screw and moving the guide back and forth to allow smooth movement of your braiding of choice.

The cutout in the underside of the foot allows your embellished work to pass smoothly as you work.

The type of stitch used is usually a straight stitch, zigzag or decorative stitch depending upon the type of embellishment that is being sewn. Braid is generally sewn to the fabric with a stitch right down the center of the braid. A Madam Sew favorite.

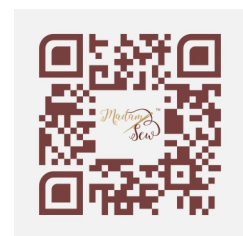

VIDEO DEMO: [Add dimension with the braiding foot](#) (click to view or scan QR-code)

III. DESCRIPTION OF THE DIFFERENT FEET

General instructions

1. Select a straight stitch or a zigzag stitch. Most of the time you will want to use a zigzag stitch.
2. Place the width of the zigzag just wide enough to clear the braid, cord, or elastic that you are using.
3. Loosen the screw on the left of the foot to allow you to move the adjustable plate forward and back to accommodate varying widths of braid, cord, or elastic.
4. Snug the plate close to the braid that you are applying to help guide the braid. Let the braid feed in as you guide the fabric on the transferred design.

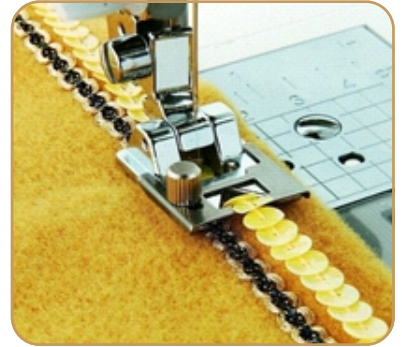

Instructions for couching elastic

1. Thread the elastic through the hole on the braiding foot from the top and under the back of the foot. Move the guide by loosening the screw and snugging it up to the elastic but allowing the elastic to slide through freely.
2. Select the overcast stitch, adjusting the width to cover the elastic.
3. Begin sewing letting the elastic slide through the foot as you sew.
4. Pull the elastic up to the degree of gathers as desired. the elastic should slide easily in the thread casing.



We strongly advise testing for the correct stretch before diving into your final piece.

Instructions for trims with twin needles

1. Position the ribbon or trim in the spot desired. Select the twin needle width desired.
2. Thread the ribbon or trim through the braiding foot and tighten the screw.



III. DESCRIPTION OF THE DIFFERENT FEET

Instructions for passementerie

1. Draw your design on your fabric first.
2. Back the fabric with tear-away stabilizer.
3. Thread the soutache cord through the hole on the front of the foot and under the back. Move the metal slide close around the trim.
4. Lower the needle into the center of the trim and begin sewing.
5. As you sew curves, do not pull the trim too tight as you sew.
6. Be sure to keep the needle in the center of the trim. Use your presser foot lever to pivot as you sew.



1/4" Quilting Foot (10)

This foot has markings so you can sew an exact 1/4" seam when piecing or create perfect 1/4" or 1/8" topstitching. This foot also features raised markings along the sides of the foot for easy and flawless pivoting.

A dream foot for the quilters out there who rely on accurate 1/4" seams for their projects. It's not just for quilters though. the foot is also great for doll clothes and many small shirt-making seams, too. The Madam Sew Quilting foot will quickly become a firm favourite.

Note: Never use this foot with a zig zag or decorative stitch as the needle will break and there is danger of injury.

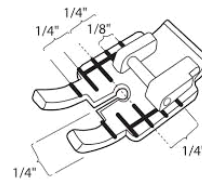

Beading Foot or Pearl Piping Foot (11)

At Madam Sew, we LOVE this one.

Want to jazz up a project? The Madam Sew Pear Piping Foot quickly and easily adds a string of pearls or ribbon of sequins to any project perfectly. It's easy to install and smooth to sew with.

This foot has many uses such as sewing seams in knitwear, attaching beads up to 4mm, and making and applying piping up to 1/4" in diameter. Also sews corded pin tucks, sews piping 1/8", 1/4" & 3/8" (for piping your machine must have a left or right needle position).

To attach beads, select a zigzag stitch wide enough to clear the beads. The width of the zigzag should be set the same as the diameter of the beads. Use a matching or monofilament thread to hold the beads to your work. We recommend reducing the pressure on the presser foot to keep the beads from dragging and creating puckers in the fabric.



III. DESCRIPTION OF THE DIFFERENT FEET

Standard Zig-Zag Foot (12)

This foot is a 'super' version of the standard zig zag foot. It has a wide open area with clear sole to allow you to work with accuracy on your projects. The Madam Sew Zig Zag foot has centre markings for stitch position and alignment allowing you to accurately gauge stitch placement for your decorative work.

The clear sole also comes with the guide hole at the front of the foot to allow you to work with small ribbons, rik rak or elastic to embellish your work even further.

Perfect for bags, pockets and cushion covers the effects can be truly stunning, where will your imagination take you?



Non-Stick Foot (13)

Non-Stick Foot (sometimes called a Teflon or Ultra-Glide foot). Why a Non-Stick Foot? Well, if you've ever tried to sew clear vinyl or laminated cotton then you know why someone created a Non-Stick Foot. And, let's not forget leather, pleather, oil cloth, and ultra-suede. Without your Madam Sew Non-Stick Foot, these fabrics are not going to cooperate. Basically, the Non-Stick foot is made of a highly smooth non stick plastic. You can see how the bottom of the foot is very smooth. The smooth, non-stick coating is what reduces friction and causes the foot to glide over the vinyl, etc.

The shape of this foot is the same as your regular straight stitch/zigzag/all-purpose foot to suit ANY situation.

Any project can be made easier when you have the right tool. Having a Non-Stick Foot is a perfect example of this. One place you might find this foot indispensable would be in making Halloween costumes. If you are attaching patches to costumes or using unusual fabrics this foot could save you hours of frustration ~ and seam ripping.



III. DESCRIPTION OF THE DIFFERENT FEET

Darning Foot (14)

The darning foot is a multi-purpose foot, not only is it used for embroidery, but it is also used for free motion quilting and of course darning, which is also just basic, old fashioned garment mending. The Madam Sew Darning foot has a distinctive circular shape.

The foot is attached to the presser foot bar by removing the existing presser foot and shank (see instructions in the beginning of this manual) and attaching the darning/embroidery/quilting foot, which has its own shank. You will need to ensure that the long arm of the foot is positioned above the screw which holds the needle in place. This will drive the movement of the foot in time with the drop of the needle allowing the user to move the fabric freely and the feed dogs are not used for this foot.

When using this foot the feed dogs must also be either dropped or covered. For embroidery and darning the fabric project should be hooped for stability. For free motion quilting the fabric is moved back and forth under the foot manually by the sewer as stitching occurs, the key to obtaining the desired stitches is moving the fabric at the correct speed, not too fast and not too slow.

Practice is definitely recommended for the free motion quilting and embroidery uses of this foot.

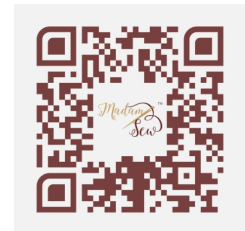

VIDEO DEMO: [Darning & Freehand Embroidery Presser Foot Tutorial](#)

(click to view or scan QR-code)
(note: the presser foot in the video has a metal part that attaches to the presser foot bar and our presser foot has a white plastic part, the use is exactly the same though. The Madam Sew foot has special plastic part for attaching so the vibrations of the machine do not loosen the thumbscrew that attaches the darning foot to the shank)

III. DESCRIPTION OF THE DIFFERENT FEET

Piping or Double Welting Foot (15)

Use this foot to couch single or double rows of cording to your fabric. It can also be used to make single and double rows of piping. The underside of foot has two grooves to accommodate the cording.

The double rows of piping, also known as double welting cord, are often found as a finishing trim in home décor.

Maximum stitch width of 4 mm and cord size between 4 and 6 mm (between 1/8" and 1/4").

Instructions:

1. Select a straight stitch.
2. Cut a strip of bias fabric approximately 4" wide. The fabric needs to be wide enough to cover the cording(s) being used plus 1 1/4" (for standard 5/8" seam allowances) excess can be trimmed off.
3. Fold the bias strip in half, placing the cord in the fold. Align the fabric covered cord under the foot and sew along the cord edge.
4. Add a second cord between the fabric layers. Move the cord under the first groove (or groove on right) in foot, and stitch along the edge of the cord.
5. Trim the excess fabric to an even width down the length of the cord.

5/9-Groove Pintuck Foot (16 & 22)

This is a firm favourite at Madam Sew. I love that delicate detailing this foot can bring to shirts and dresses for very little effort. The Pintuck Foot creates even tucks and is easy to use. Simply install a Twin Needle, feed your fabric through the foot, and watch as perfect pintucks form instantly.

A Pintuck Foot can be used with or without cording. Thin cording (1/16) creates a bold and defined pintuck. When using cording with your Pintuck Foot, it is best to use a cording guide plate cover. This ensures your cording is fed directly into the foot center. The number of grooves to use depends on the weight of your fabric. The heavier the fabric, the less grooves. The lighter the fabric, the more grooves. See the video's or the blog post for detailed explanation on how to use the pintuck feet.



15

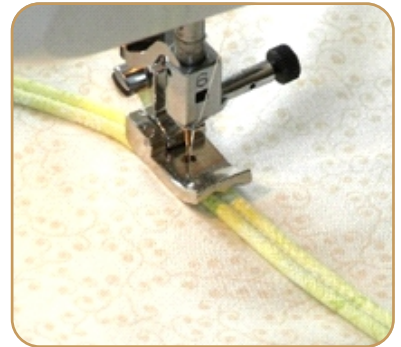

16

22

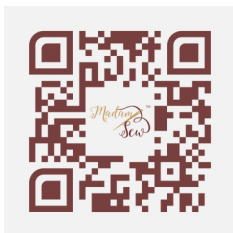

VIDEO DEMO: [How to Use a Pintuck Foot](#) (click link to view or scan the QR-code)

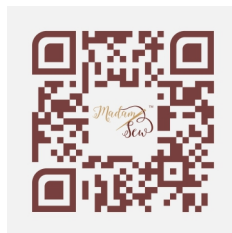

VIDEO DEMO: [How To Use A Pin Tuck Foot with Cording](#) (click link to view or scan the QR-code)

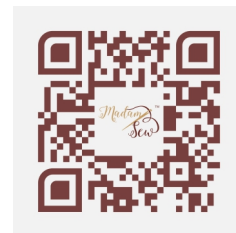

BLOG POST: [How to Use the Pintuck Foot](#) (click link to view or scan the QR-code)

III. DESCRIPTION OF THE DIFFERENT FEET

1/4 " Quilting Foot with guide (17)

Similar to the 1/4" quilting foot but with a guide built in at the right side. Possibly of more use for an inexperienced quilter who needs that added reassurance the fabric is not slipping away and ting a wonky seam as you sew.

I always use this foot if I am in a rush or working on a jelly roll race quilt as it takes away a level of thinking allowing me to concentrate on feeding the fabric though smoothly.

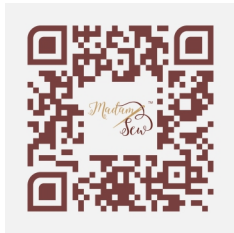

BLOG POST: [Quilting Foot or Patchwork Foot](#) (click to view or scan QR-code)

VIDEO DEMO: Included in the above blog post

III. DESCRIPTION OF THE DIFFERENT FEET

Gathering Foot or Shirring Foot (18)

Fabric layers are placed under the foot and gathered automatically. Make ruffles for garments, pillows, or other home décor items.

A number of factors will affect the amount of fullness that is achieved:

Stitch Length: If adjusted to a longer stitch - more fullness. If the stitch length is shortened - less fullness.

Needle Tension: If needle tension is tightened: more fullness. If less tension: less fullness.

Fabric Types: If your fabric is light, such as batiste or lace, you will have more fullness. If the fabric is heavier, such as broadcloth or decorator fabrics, the fullness will be less.

This foot attaches directly to your shank. You have to remove your presser foot holder first before you can attach this foot to your machine.

You can remove the presser foot holder/bonus adapter following the steps in the picture.

Unscrew the presser foot holder screw (thumbscrew) (3) with a screwdriver (1) and remove the presser foot holder/bonus adapter (2). The presser foot holder can look different on your machine, this picture shows a Brother sewing machine.

If you look closely at your Gathering Foot - you will see a slot on the bottom. When using this slot, you can gather the bottom layer of fabric while attaching it to a flat top layer, such as on a waistband. I love that you can ruffle at the same time as attaching a skirt to its waistband. Perfect for creating a child or doll ruffled skirt.

When testing your machine for adjustments to achieve desired fullness, work with 10" increments of fabric, trim or elastic. This makes it easier to determine the adjustments and how much change is needed for your project. Always test on your project fabric on the same grain line as you will be using in your finished project.

Using the cross grain of the fabric will make prettier gathers than the straight of grain. For additional fullness, hold your finger behind the foot while sewing so the fabric gathers against your hand.

VIDEO DEMO: [How to Use a Gathering Foot](#)

INFO PAGE: [All About the Gathering Foot](#)

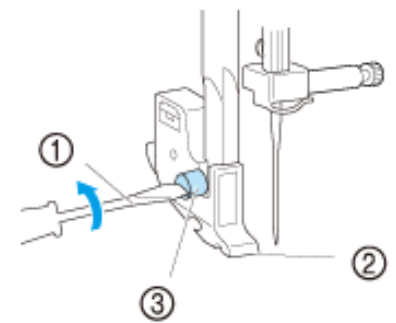

III. DESCRIPTION OF THE DIFFERENT FEET

Knit Foot or Tricot Foot (19)

This foot is cleverly designed to hold the fabric down firmly as the needle comes down and pierces the fabric and then let up on the fabric as the feed dogs rise and carry the fabric along for the next stitch. Effectively you are pinching the layers of fabric together to ensure no slipping as you sew.

There is a little rubbery plastic blue "stopper" piece that is controlled by the flange or arm on the side of the foot. IT grips the knit fabric firmly stopping and slip or slide as you work.

This arm fits nicely over the needle screw-bar. It moves as the needle bar moves, and there is a little spring that makes it - well - springy!

This knit foot perfect for lightweight knits and very slippery lightweight or stretchy fabrics of all sorts.

With the needle down in the fabric the lever is in the position where the spring pushes the plastic down on the fabric. Then, as the lever rises with the needle bar, it forces the plastic piece up off the fabric and another stitch is on the way!

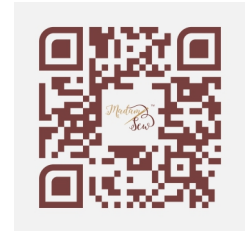
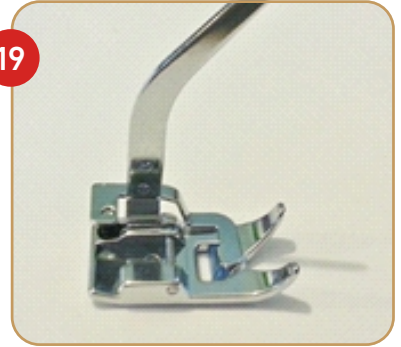

VIDEO DEMO: [How to Use a Knit Foot](#) (click to view or scan QR-code)

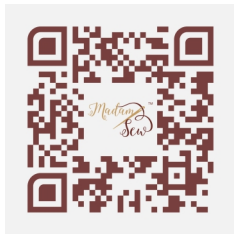

This foot is the simpler version of a walking foot. For a detailed comparison of the two you can watch this video: [Walking foot vs knit foot - Which is the best for sewing knit fabrics?](#) (click to view or scan QR-code)

III. DESCRIPTION OF THE DIFFERENT FEET

Adjustable Zipper Foot (20)

This foot is designed to allow the placement of stitching close to a raised edge: zipper insertion, corded seams, tubular cording, slipcover welting and similar applications. Basically, the zipper foot prevents you from sewing into the zipper teeth.

If your sewing machine won't let you change needle positions, the Madam Sew Adjustable zipper foot is for you. It has a slider on the back that allows you to change the foot's position. Loosen the screw to adjust the slider and position of the foot in relation to the needle. Align the foot with the zipper. Don't forget to re-tighten the screw once you've adjusted the foot's position.

The foot is attached to the presser foot bar by removing the existing presser foot and shank and attaching the zipper foot, which has its own shank. This foot can look rather confusing before it is attached to your sewing machine. Remember the large flat foot, which faces you in the packaging needs to go flat down on the feed dogs of your sewing machine. It should all make sense for attaching it at this point.

A really simple way to use the foot is to treat your zipper as if it was any other fabric by placing it and the fabric right sides together, then sew the seam.

Turn and press.

If you are not making clothing where you don't want it to show, then edgestitch it like the pros do. It takes only seconds, literally. No tape, no pins; just you, the zipper, your fabric and sewing machine.

A more traditional technique is shown in the video.

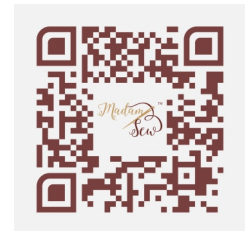

VIDEO DEMO: [Adjustable Zipper Foot](#) (click to view or scan QR-code)

III. DESCRIPTION OF THE DIFFERENT FEET

Fringe Foot or Loooper Foot (21)

A simple to use foot to produce a couple of stunning embellishments for your sewing projects. Fringes, chenilles and loops can be used to great effect on cushions, clothes, quilts, bags, toys and more.

Use a zigzag or ladder stitch and stitch length depending on the effect you want, a shorter stitch gives a denser fringe effect.

Notice in the center of the foot there is a raised metal piece that looks like an upside down ice skate. Don't worry, it's not sharp. It just "looks" like an ice skate. This center bar is what the thread stitches over to create the fringe which is really just large loops. The wider the zigzag or ladder stitch used, the longer the fringe loops will become. ne.

A more traditional technique is shown in the video.

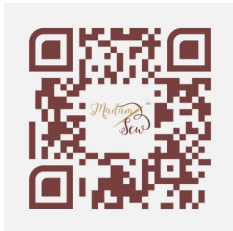
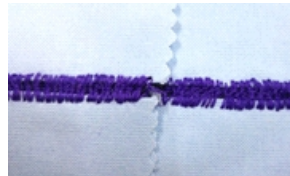
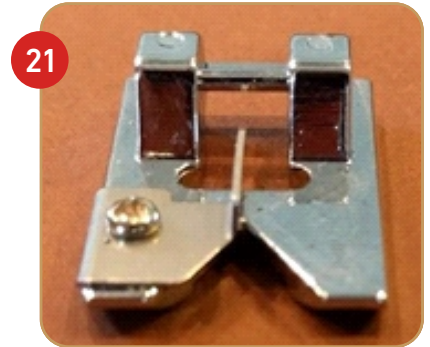

VIDEO DEMO: [How To Use a Fringe Foot](#) (click link to view or scan the QR-code)

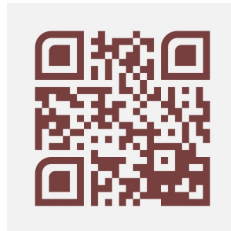

BLOG POST: [4 Fun Ways to Use a Fringe Sewing Foot](#) (click link to view or scan the QR-code)

III. DESCRIPTION OF THE DIFFERENT FEET

5-Groove Pintuck Foot (22)

This foot is explained together with the 7-groove pintuck foot (16)

Darning Foot 2 (23)

Similar in use and function to the other Darning Foot (14). This Darning Foot has a transparent sole that is a bit wider. This foot allows for a 7 mm extra wide zigzag stitch. The other one is limited to 5 mm. It is up to your personal preference which one of the two you want to use.

Ensure that you attach the foot with the arm over the needle screw bar to work the spring which lifts the darning foot.

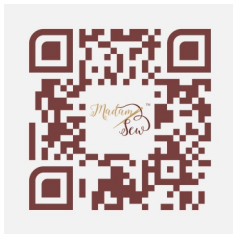

VIDEO DEMO: [How to sew using a Darning Foot](#) (click link to view or scan the QR-code)



Stitch Guide Foot or Presser Foot with Ruler (24)

This Presser Foot has a Ruler and can easily sew the precise even parallel lines you want while topstitching.

Use it for projects that require accuracy, such as garments, topstitching or piecing while quilting. It is also the perfect foot for gradual increases in echo quilting effects around a shape in an applique quilt.

The ruler allows to stitch precise seam allowances up to 1" wide and has a precision scale that goes up every 2mm.

When sewing a curve, keep the edge and the presser foot scale at right angles, In order to get a good curve effect.

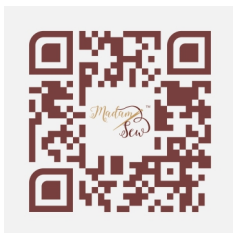
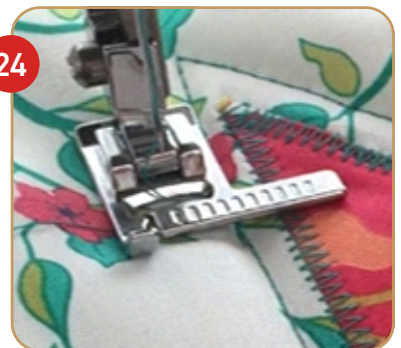

VIDEO DEMO: [Stitch Guide Foot Tutorial Video](#) (click link to view or scan the QR-code)

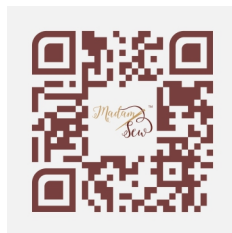

BLOG POST: [How to use the Presser Foot with a Ruler](#) (click link to view or scan the QR-code)

III. DESCRIPTION OF THE DIFFERENT FEET

5/7 Hole Cording Foot (25 & 26)

Use this foot to attach decorative cords and threads. Select threads and small cords that will glide easily through the holes on the cording foot of your choice. Select the multi-step zigzag stitch and adjust it wide enough to catch the outside threads. Now that your threads are under control, you can place both hands on the fabric to guide and move through the pattern you select.

What is cording?

Cording is the technique of binding or connecting an uncovered cord embellishment to a fabric. It is different from welting, which is covered cording, meaning that the cord is encased inside a sleeve of fabric, then attached to another fabric, usually for a heavy duty project, a pillow edge for example for a decorative effect.

Cording is also different from piping which is a lighter weight covered cord, placed inside of a seam or along a project edge as a trim on a garment. These are generally home décor techniques, but cording and piping can be used to decorate garments.

There are also piping and welting feet, which have grooves on the underside of the foot, and work in a similar manner, but works differently than multi-cording feet.

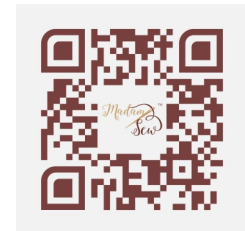
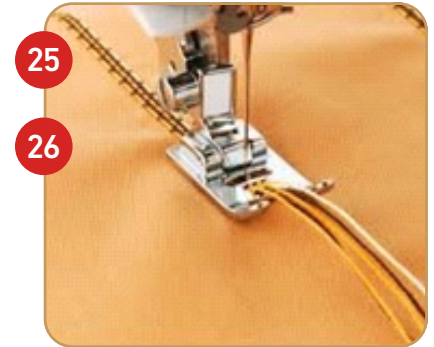

VIDEO DEMO: [How to use a 5 hole cording Foot](#) (klik link to view or scan the QR-code)

III. DESCRIPTION OF THE DIFFERENT FEET

Edge Joining Foot or Stitch-in-the-Ditch Foot (27)

The edge joining foot is used for edge stitching, stitch-in-the-ditch stitching and heirloom sewing. The center bar is the perfect guide for fabric edges. Unlike the blind hem foot where the bar extends into the needle hole, the edge joining foot's bar stops before the hole making it possible to use any stitch on your machine with this foot.

The marks on each side make aligning your fabrics and turning easier. The second mark on the left side lines up with the slight indentation on the right side of the foot. Use these marks to start sewing two lace edges or fabric and lace in the same place.

To begin sewing place the edge of the fabric, lace or trim against the left edge of the bar on the foot. Choose a straight or zigzag stitch that will catch the edge of the fabric or trim as well as sew into the background fabric.

Always ensure that you have worked any raw edges, either with pinking shears or a zig zag stitch to prevent fraying as once the fabrics have been joined this will become an incredibly fiddly task.

Note: You should always press your fabric under to create the seam allowance for your project. Then once you have finished joining two fabrics you have a seam created which has already been pressed open with no raw edges.

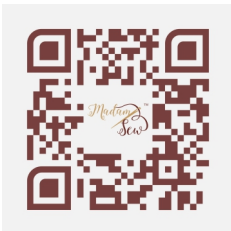

VIDEO DEMO: [Edge Joining Foot Video Tutorial](#) (click link to view or scan the QR-code)

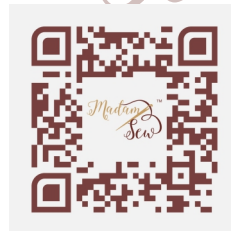

BLOG POST: [How to Use the Edge Joining/Stitch-in-the-Ditch Presser Foot](#) (click link to view or scan the QR-code)

III. DESCRIPTION OF THE DIFFERENT FEET

Overcast Foot (28)

This foot delivers a consistent and accurate overcasting stitch for a serged effect using your sewing machine. Thread is locked around the edge of fabric, aligned with the edge, to prevent fabric from raveling.

Perfect professional edges for seams on garments.

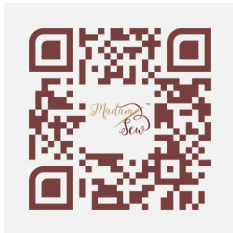

VIDEO DEMO: [How To Use an Overcast Foot](#) (click link to view or scan the QR-code)



Open Toe Foot (29)

The large opening presser foot provides an unobstructed view of your work while sewing since there is no bridge between the toes. In addition, there is a groove on the underside to allow dense decorative stitches to pass underneath without jamming. Both of these characteristics make this Foot ideal for doing applique and decorative stitching.



III. DESCRIPTION OF THE DIFFERENT FEET

Rolled Hem Foot and Flat Hem Foot (30 & 31)

These feet are perfect for hems that are too small to sew by hand. It automatically curves under a 3 (1/8") or 6 mm (1/4") double hem while stitching with a straight stitch. This foot works best on blouses, gowns, and other projects with lightweight fabric.

When hemming circle skirts these feet are an excellent option.

To use simply turn over the edge of the fabric, feed into the round spiral at the front center of the foot and sew down with a zig zag stitch for the rolled hem foot or a straight stitch in the centre of the flattened seam of the Flat hem foot.

The difference between the rolled hem foot and the flat hem foot is on the base of the foot. The rolled hem foot has a round groove that allows for a puffier finish, hence the zig zag stitch to give the fabric room to curl.

The flat hem foot has a squared off groove which compressed the folds into a neat flat hem.

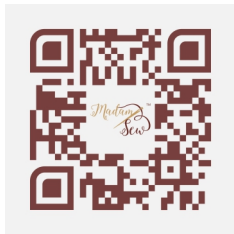
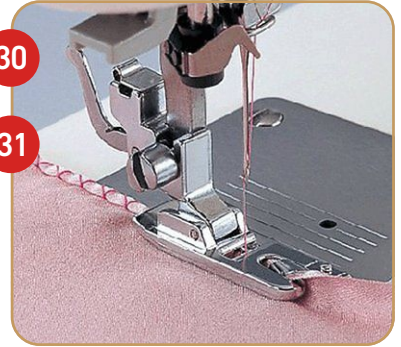

Difference in use is very clearly explained in the following article from Threads Magazine: [Mastering the Narrow Hemmer](#) (click link to view or scan the QR-code)

In the article the name for the rolled hem foot is rolled hemmer. The name for the flat hem foot is narrow hemmer.

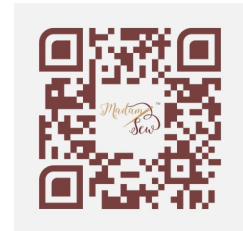

VIDEO DEMO: [How To Sew Rolled Hems with the Narrow Hemmer Foot](#) (click link to view or scan the QR-code)

III. DESCRIPTION OF THE DIFFERENT FEET

Adjustable Bias Binding Foot (32)

The adjustable bias binder foot is indeed a marvel. This is a great foot for use on bags, skirts and giving a hem a bright pop of colour. Circle skirts or ruffles in particular will make you fall in love with the Madam Sew Adjustable Bias Binding foot.

The foot can be used with commercially made bias binding or with bias binding that you make yourself. There are also bias making machines on the market now that make creating your own bias binding easy, as well as bias making rulers that assist the sewer in cutting the bias strips consistently the same width.

The adjustable bias binder is a clear plastic foot with a screw and markings on the foot that allow for the adjustment of the width of the finished binding. This foot is generally used to sew double-fold bias tape to the edge of a project. The width of the finished binding is determined and the foot is adjusted to achieve the desired width. The foot has two screws, one to hold the bias strip while it is being sewn; the second screw is used to adjust the foot to the right or left of the needle so that the stitching catches the edge of the binding.

The binding is fed into the upper and lower guides in the foot from the right.

The main fabric being bound is fed into the center groove of the foot from the left, creating a binding sandwich.

Once you start to sew you are joining the binding to the fabric in one simple step creating a clean line of stitching front and back as you go.

Note: This foot is not suitable for quilt binding. When binding quilts the wadding is too thick to pass through the centre of this foot.



VIDEO DEMO: [Bias Binding Foot Video Tutorial](#) (click link to view or scan the QR-code)

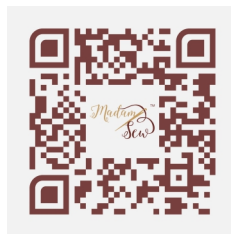

BLOG POST: [Bias Binding Tutorial](#) (click link to view or scan the QR-code)



REFERENCES

01. i1.wp.com/i1240.photobucket.com/albums/gg496/sewingsilly/13_zpsd9f59192.jpg
02. www.sewingmachinesplus.com/viking-braiding-foot-4118500-45.php
03. www.the-sewing-partner.com/braiding-foot.html
04. babylock.com/ftp/whitepapers/LNIS_BLDYFTKIT.pdf
05. sewingmachine221sale.bizland.com/store/page60.html
06. www.the-sewing-partner.com/invisible-zipper-foot.html
07. blog.sewmucheasier.com/a-quick-guide-to-your-sewing-machine-presser-feet/
08. www.thecolorfulworldofsewing.com/Singer-Open-Toe-Embroidery-Presser-Footer.html
09. www.the-sewing-partner.com/cording-foot.html
10. www.sewingmachinesplus.com/BL-OCF.php
11. www.sewingmachinesplus.com/ESG-DS.php
12. www.the-sewing-partner.com/roller-foot.html
13. www.sew4home.com/tips-resources/sewing-tips-tricks/accessories-we-love-roller-foot-velvet-more
14. www.the-sewing-partner.com/darning-foot.html
15. www.the-sewing-partner.com/bias-binder-foot.html
16. <https://eyeletsintheseams.blogspot.be/2010/06/janome-elna-tricot-foot.html>

Madam Sew™

