



# ORACLE LIGHTING TECHNOLOGIES

LED PEDESTRIAN LINEAR WARNING LAMP

ORACLE PART# 2912-003

## OBJECTIVE

ORACLE Part # 2912-003 Warning Lamp promotes worker and workplace safety. The LED Safety Warning light is mounted to a forklift or other moving vehicle or equipment and projects a bright line on the floor surface. The LED Pedestrian Lamp is designed to provide a visual warning for pedestrians in the vicinity of moving machinery. The bright line on the floor is clearly visible to pedestrians in the area, regardless of the ambient noise, alerting them to the nearby presence of a hazard.

**CREE**   
LEDs



## SPECIFICATION

- Operating Temp: -40° to 140°F
- Operating Voltage: 12V-80VDC
- Light Pattern: Linear Beam (Line)
- LED Color: RED
- Lens Material: PMMA
- Housing: Cast Aluminum
- Finish: Hard Coat Anodized
- Mount: Post Mount
- Connector: DTM04-2P
- LED Type: 3W Cree LED
- IP Rating: IP68
- Cable: 18AWG
- Cable Length: 500mm



## DIMENSION

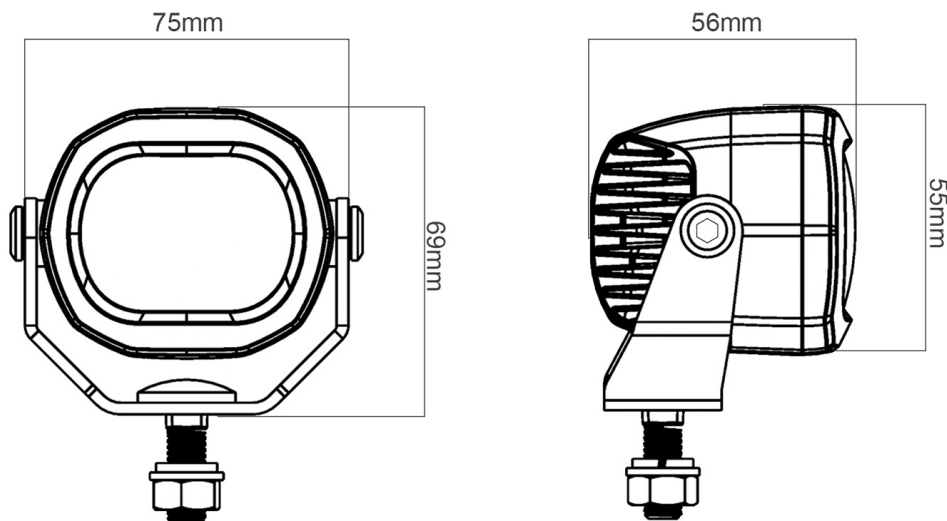

**ORACLE**  
LIGHTING

[www.oraclelights.com](http://www.oraclelights.com)

© 2019 ORACLE LIGHTING TECHNOLOGIES

4401 Division St.  
Metairie, LA 70002  
P: 1 (800)407-5776  
F: 1 (800)407-2631