

ORACLE LIGHTING

2917-023 - USER GUIDE

Before you Begin:

- Read all instructions carefully and study diagrams before installing lights.
- Check with state and local guidelines governing usage and proper mounting of auxiliary lamps.
- Disconnect battery ground cable during installation to avoid accidental short circuits.
- Be sure to use correct gauge cable, fuses, and relays for proper installation.
- Professional installation is recommended.

Installation Guidelines:

- Included hardware requires a 13/32" hole for mounting with the included bracket.
- Use Included locking washer and adequate torque to properly secure the lamps.

Wiring Guidelines:

- Black: Ground (-)
- Red: Power (+)
- White: White LED Lights (+)
- Yellow: Amber LED Lights (+)

Note: E-mark NOT APPLICABLE when using amber parking light.

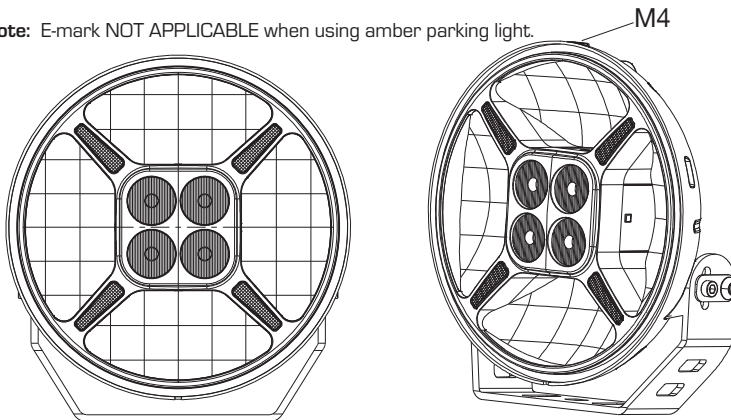

Product Warnings:

- Use this product only within the specified input voltage (9V - 36V DC).
- This light may become hot under continuous use. Use caution to avoid burns.
- Keep heat-sink clean and exposed to air flow to maintain adequate cooling.