

Premium



# SG40DEH

Electric release

Base free lift

(4 ton)



**Model:** SG40DEH

**Product:** 4 Ton electric release - Clear floor

**Description:** Clear Floor lift version has no obstruction between the 2 posts. They are considered ideal for when transmission jacks are constantly in use or cars with a low ride height. The steel ropes and hydraulic pipes go over the top.

<b>Features:</b>	<b>Benefits:</b>
Electric release	Less physical labor
Clear floor design	The hydraulic hose and equalization cables run across the top of the lift through a metal bar (conduit) that connects both columns in the Overhead lift. The metal bar (conduit) is there to guide the hose and cables and is not designed to support any vertical weight. There is a cut-off cable (connected to the power unit) located just below the metal overhead conduit which "kills" power to the motor preventing damage to the top of the car, if the lift operator was not paying attention.
Dual cylinders	Master and slave column, to assist with lifting of vehicles.
Dynamic test 115% of the rate capacity	Ensures the hoist works correctly through its full cycle of operation
Static test: 150% of the rated capacity	Static load testing, to ensure the lifts can handle the recommended tonnage. Safety test.
Preset related loading	Designed to avoid overload running
ABS control box, 24v low voltage control system	Conforms to ISO standards and electrical components of the lift.
High quality seals from Italy	Seals can withstand high pressure and mechanical stress.
Quality power rack	Ensures safety at all heights.
Conforms to CE requirements	The CE Mark on a product or machine identifies it as complying with all the of safety requirements established by the European Union.
Easy to install	Requires a flat floor and solid concrete base for bolting.
	<b>Versatility:</b> A 4-ton 2-post vehicle lift is suitable for a wide range of vehicles, including cars, SUVs, and pickup trucks. This versatility allows the fitment center to accommodate various customer vehicles, expanding its service offerings and customer base.

	<p><b>Improved Accessibility:</b> 2-post lifts provide unobstructed access to a vehicle's undercarriage. This makes it easier for technicians to perform various maintenance and repair tasks, including brake work, suspension repairs, and exhaust system maintenance.</p>
	<p><b>Time Efficiency:</b> Base plate 2-post lifts are known for their quick setup and lifting times. This efficiency reduces the time required to position a vehicle on the lift and complete service tasks, resulting in increased overall productivity.</p>
	<p><b>Space Efficiency:</b> Base plate lifts typically have a smaller footprint compared to other types of vehicle lifts, making them suitable for fitment centers with limited available space. This allows for more efficient use of workspace.</p>
	<p><b>Safety Features:</b> Base plate 2-post lifts come equipped with safety mechanisms, such as safety locks and safety latches, to ensure the vehicle remains securely elevated during maintenance. These safety features enhance technician safety and reduce the risk of accidents.</p>
	<p><b>Technician Comfort:</b> Using a 2-post lift eliminates the need for technicians to work on their backs or under vehicles on the floor. This improved ergonomic working environment reduces physical strain and discomfort, leading to higher job satisfaction and productivity.</p>
	<p><b>Cost Savings:</b> While the initial investment in a 2-post lift may be substantial, it can lead to cost savings over time. Faster service times, reduced labor requirements, and increased job throughput can result in lower operating costs and improved profitability.</p>
	<p><b>Customer Satisfaction:</b> The efficiency and quality of service facilitated by a 2-post lift can lead to higher customer satisfaction. Satisfied customers are more likely to return for future service needs and recommend the fitment center to others.</p>
	<p><b>Competitive Advantage:</b> Equipping the fitment center with a base plate 4-ton 2-post lift can set it apart from competitors that lack such advanced equipment. It can attract more customers and enhance the center's reputation in the market.</p>

	<b>Compliance and Regulations:</b> Using proper lifting equipment ensures that the fitment center complies with safety and environmental regulations. This reduces the risk of fines or legal issues and helps maintain a positive reputation.
	<b>Long-Term Investment:</b> High-quality base plate 2-post lifts are built to last, providing a reliable and long-lasting solution. This long-term investment can offer a high return on investment over the equipment's lifespan.
	<b>Long-Term Investment:</b> High-quality base plate 2-post lifts are built to last, providing a reliable and long-lasting solution. This long-term investment can offer a high return on investment over the equipment's lifespan.
Training available	Technicians can be professionally trained to use the machine and get the maximum benefit from it.
1 year warranty	The machine will be repaired if there are any factory faults and can be replaced if required.
Spares available	Should you have a breakdown you will not have to wait for your machine to be repaired. If there is anything we don't have, we fly it in directly from the Suppliers.
Operational videos	Technicians can learn how to operate the machine by watching a video, which is easier and more simple than written instructions.

## Important notice!

- Lift must be installed indoors.
- Approved installers must be used when installing lifts or warranty will be void.
- All electrical connections must be done by a qualified Electrician, and each unit requires a separate isolator.

Technical information	
Lifting capacity	4000 kg
Lifting height	1900 mm
Min height	100 mm
Lifting time	50s
Voltage	220v
Power	2.2kW
Inside width	2803 mm
Post height	3904 mm

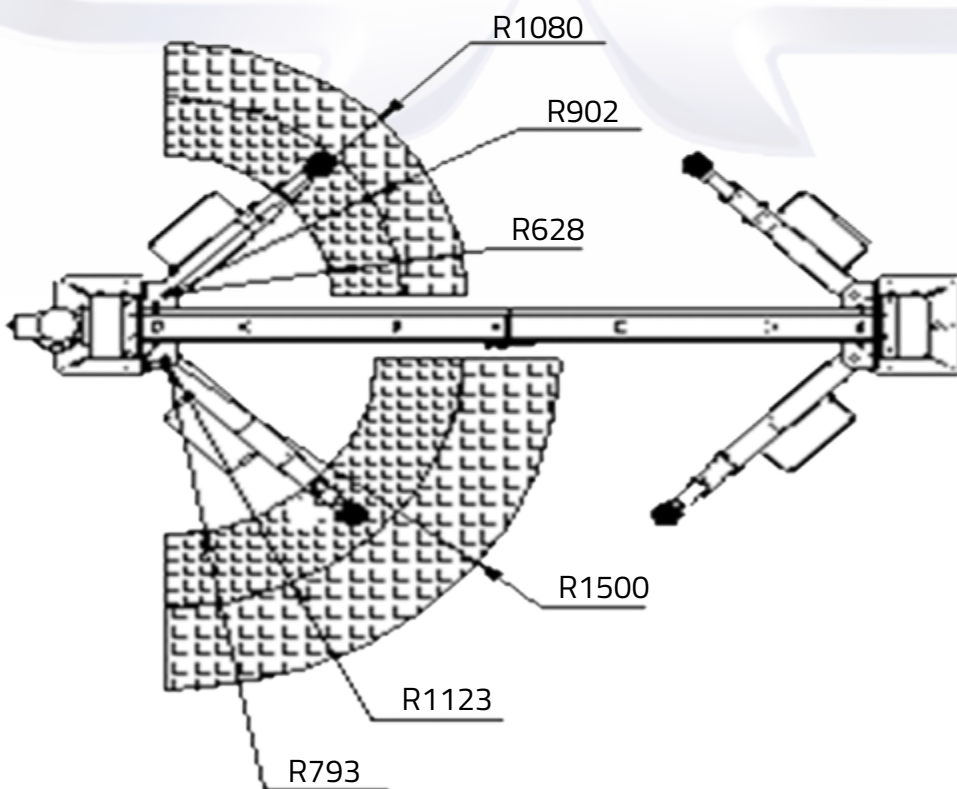
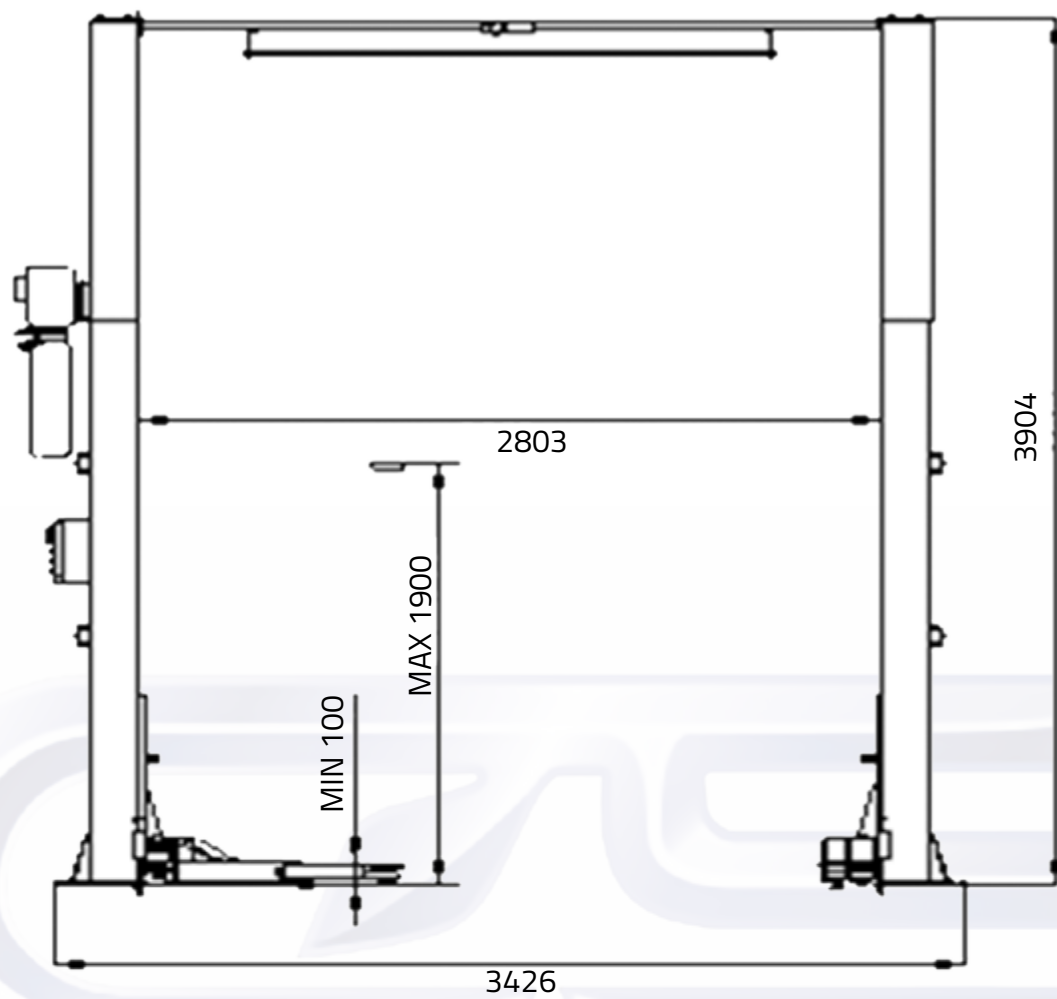

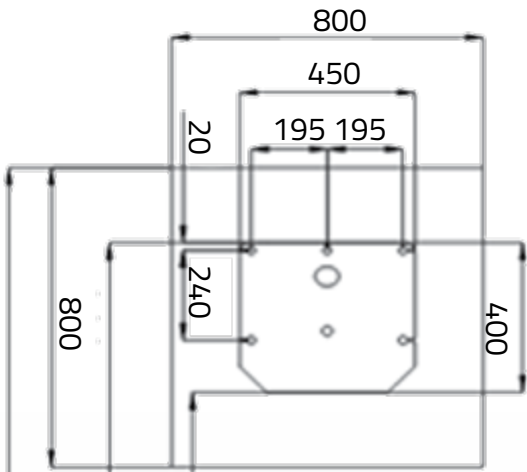

3886  
3426  
2626

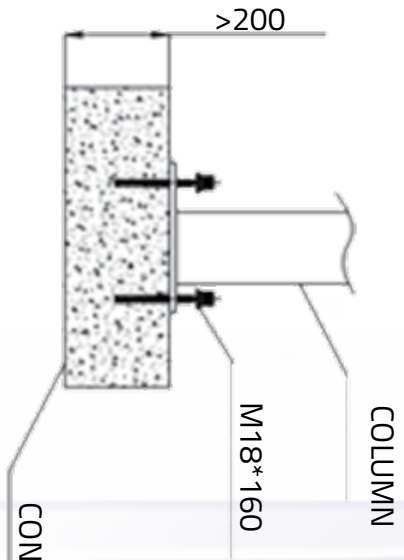
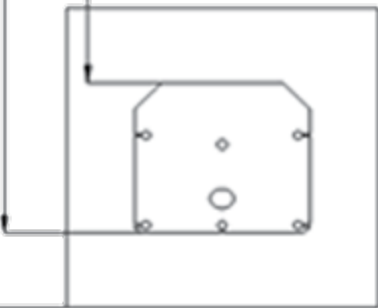

CONCRETE STRENGTH 3000PSI (2.1KG/MM<sup>2</sup>)

