

Elite Acoustics Engineering

GigMix 4-1 4 Channels Mini Digital Mixer

Quick Guide Handbook - V1.02

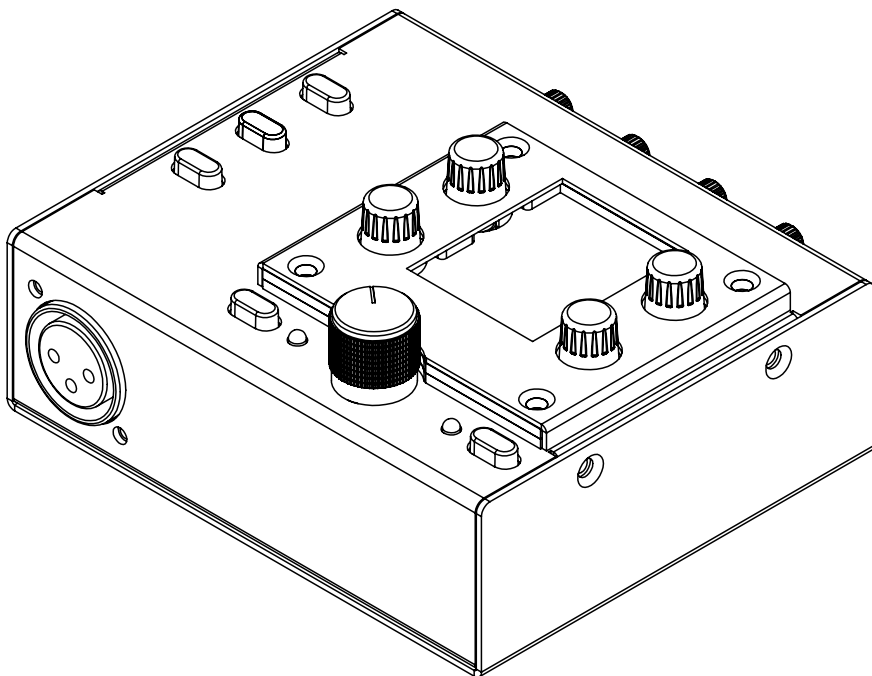

WHAT IS IN THE BOX

Your GigMix 4-1 package contains the following:

- (1) GigMix 4-1 unit
- (1) AC to 12VDC Power Supply Adapter

NOTE: Due to continuous development and improvements of our products, features and specifications are subject to change without notice. All weights and measures are approximate.

For a copy of the complete User's Manual, please visit: www.eliteacoustics.com

- Jan-28-2021

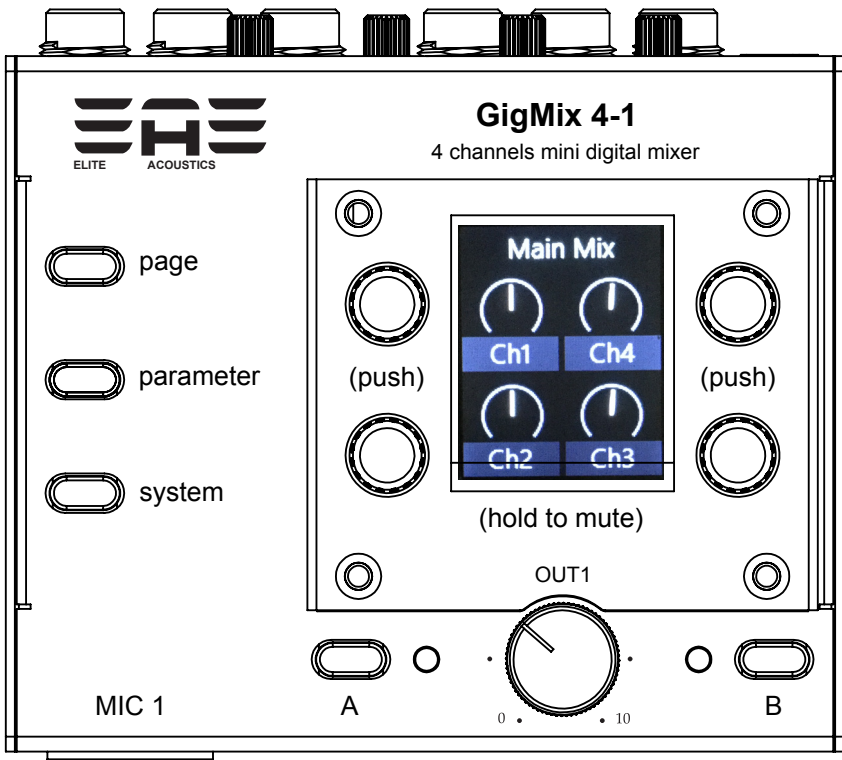

LCD FUNCTIONS

Menu Buttons with LCD:

Press any of the 3 menu buttons(black button located to the left of the LCD) or 4 encoders(blue knobs located around LCD) to access and adjust features and settings. Most menus have several pages of options, which are adjusted by turning the corresponding encoder.

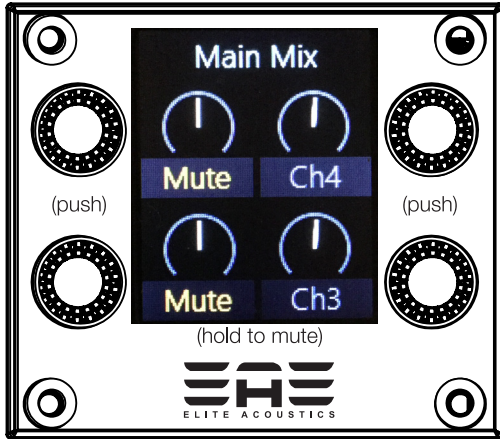

“MUTE”

HOLD down the
Corresponding encoder
to **MUTE** or **UNMUTE** each
channel.

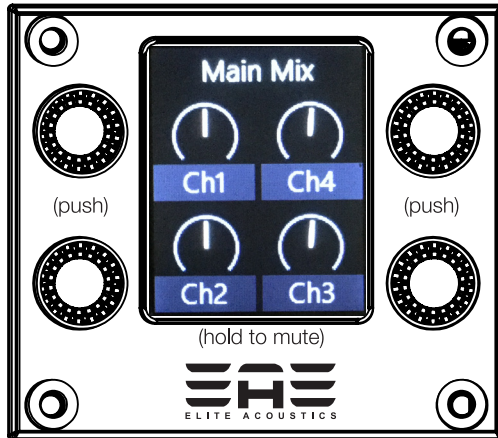

PRESS the “page” button to access these FUNCTIONS



“Main Mix”
Adjust the level of each of the 4 channels sent to the Main MIX Outputs.



“Aux Mix”
Adjust the level of each of the 4 channels sent to the Aux Mix Outputs.

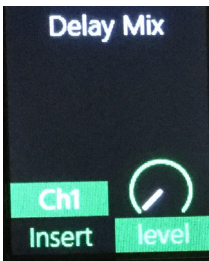

“Delay Mix”
Select the Chan which delay is inserted and Delay Mix Level.



“Reverb Send”
Adjust the Reverb Send level of each of the 4 channels.



PRESS the corresponding Encoder knob for these Functions.
use the corresponding Encoder knob for these Functions.



“Channel EQ”
 Adjust for each channel
 Low
 Mid
 Mid Freq
 High

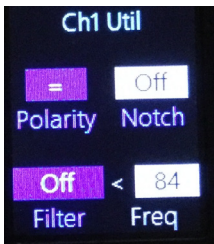

“Channel Util” - more details on next page.
 Polarity (=) or (-)
 Notch Filter
 Filter - Off/Highpass/Notch
 Filter Freq.



“Channel Dyn”
 Adjust levels for
 Gate
 Compressor

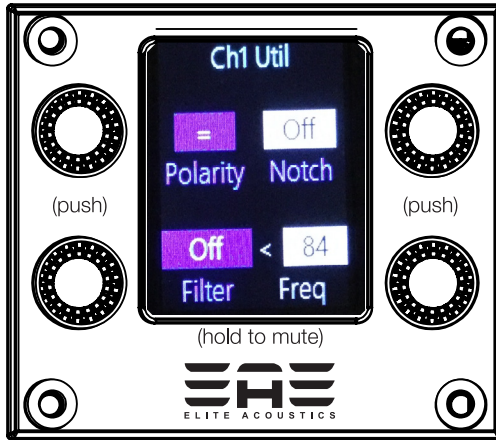

use the corresponding Encoder knob for these Functions.

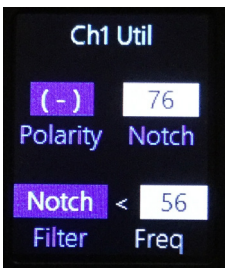

“Channel Util”

Input Phase Polarity is (-) Reversed.

Notch - 76 Hz.

Filter - Notch 56 Hz.

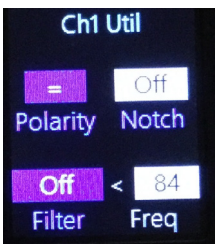

“Channel Util”

Input Phase Polarity is (=) - NOT reversed.

Notch - OFF

Filter - OFF

Filter Freq. - 84 Hz.

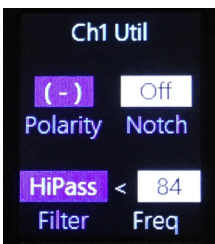

“Channel Util”

Input Phase Polarity is (-) Reversed.

Notch - OFF

Filter - HiPass

Filter Freq. - 84 Hz.

Editing “Main Mix” parameters

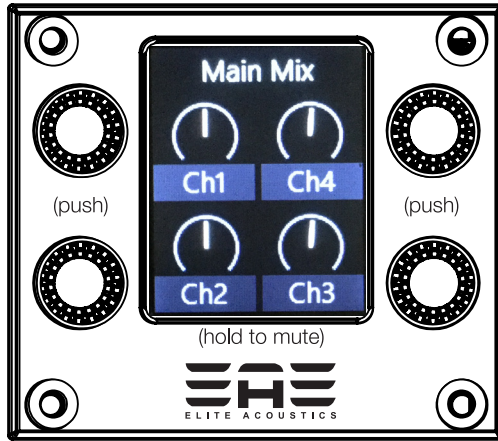

page



parameter



system

PRESS the “parameter” button to access these FUNCTIONS

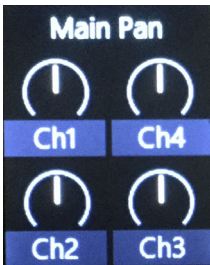

Preset “Parameter” key

Adjust the Main Mix stereo panning for each of the 4 channels.

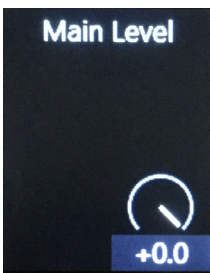

Preset “Parameter” key

Adjust the Main Mix output Level.

Editing “Aux Mix” parameters

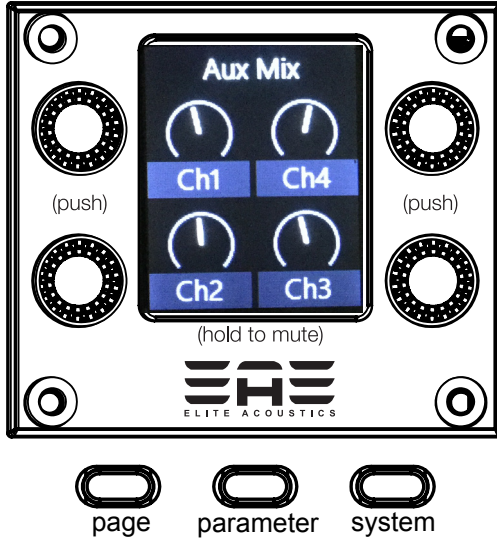

PRESS the “parameter” button to access these FUNCTIONS

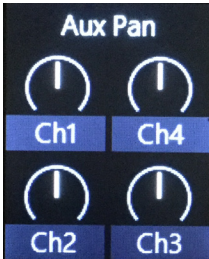

Preset “Parameter” key
Adjust the AUX stereo panning for each of the 4 channels.

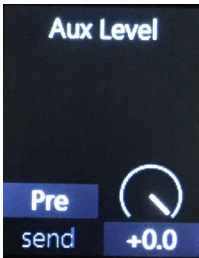

Preset “Parameter” key
Adjust Aux Send connection - “Pre” or “Post”
Pre - Pre “Main Mix level”
Post - Post “Main Mix level”
““
Adjust the Aux Mix output Level.

Editing “Delay Mix” parameters

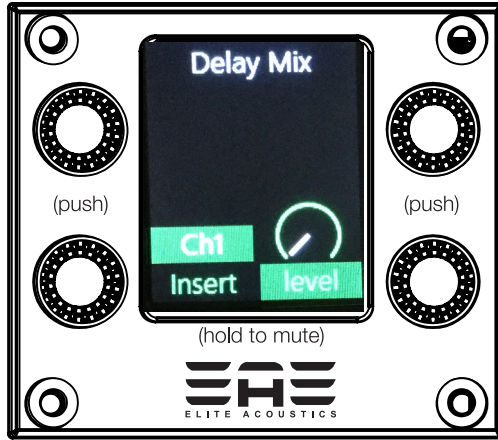

PRESS the “parameter” button to access these FUNCTIONS

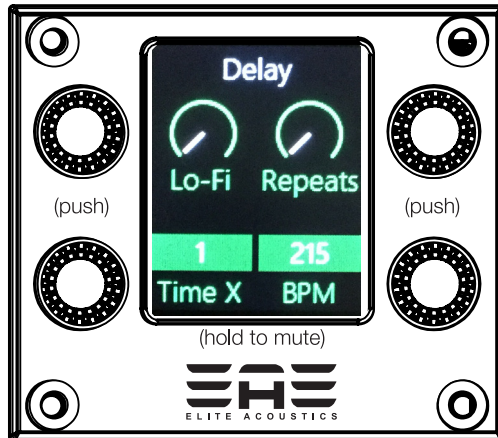

Preset “Parameter” key

Adjust the 4 Delay Parameter by the corresponding encoder knobs.

Editing “Reverb Send” parameters

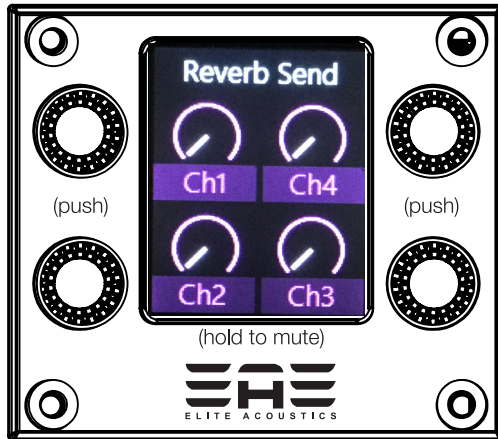

PRESS the “parameter” button to access these FUNCTIONS

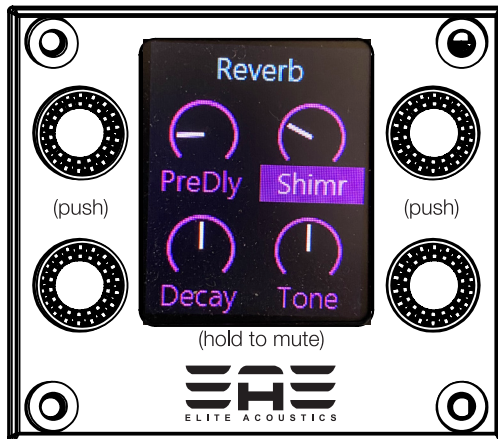

Preset “Parameter” key

Adjust the 4 Reverb Parameter by the corresponding encoder knobs.

“PreDelay” “Decay” “Tone”
and “Shimmer”

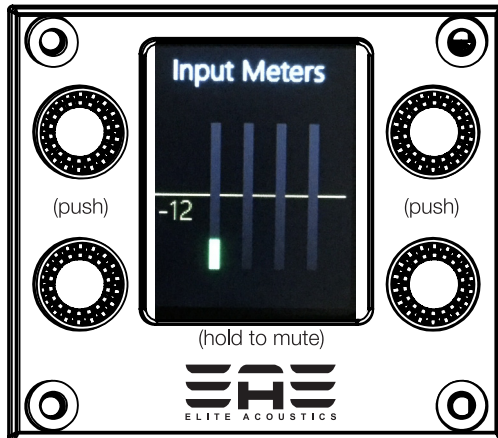

PRESS the “system” button to access these FUNCTIONS

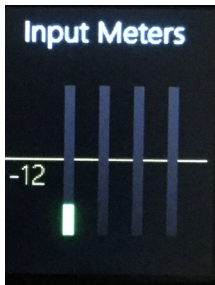

Input Meters

It is critical to adjust the normal input levels to be **below -12db level to avoid Clipping** the inputs of the StompMix 4. Distortion can occur when inputs are clipping. CHAN 1 and CHAN 2 have input level knobs and PAD switches, CHAN 3 and CHAN 4 require input level control from the external device.

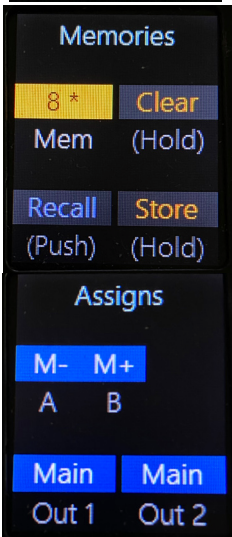

“Memories”

There are 10 scenes that can be save. Use the Corresponding encoder to make changes. “Push” - push the encoder
“Hold” - push/hold the Encoder.

(*) next to the “Mem” number means sences is stored in that location.

“Assigns”

“A” and “B” footswitch have assignable functions. See next page for more details.

Main Mix and Aux Mix outputs can be assigned to the 1/4” L/R jacks or the 1/8” jack.

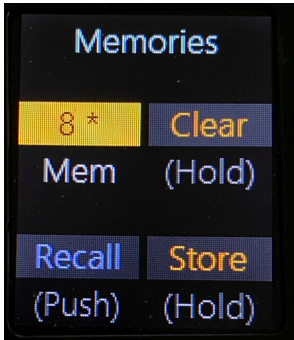
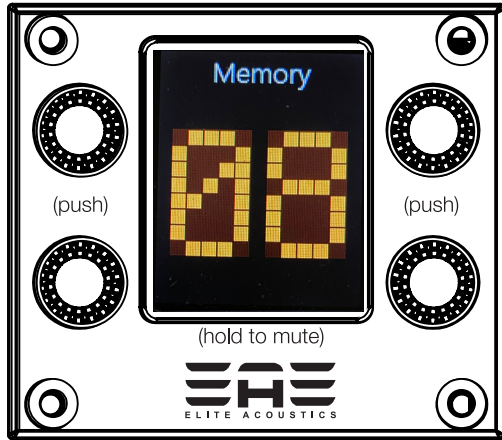

“Memories”

Mem - indicated the Memory slot #
 Clear - to Clean Memory slot indicated
 Store - to Store Memory slot indicated.
 “Press” and “Hold” - push/hold the Encoder.

Recall - to recall the memory indicated.
 “Push” - quick press ONLY. DO NOT hold.

When the foot switches are assigned to "M- M+" if pressing a foot switch results in a memory being loaded (at least two memories are not empty), a page pops up showing the number of the recalled memory in large font.

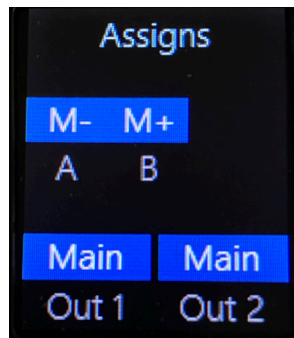

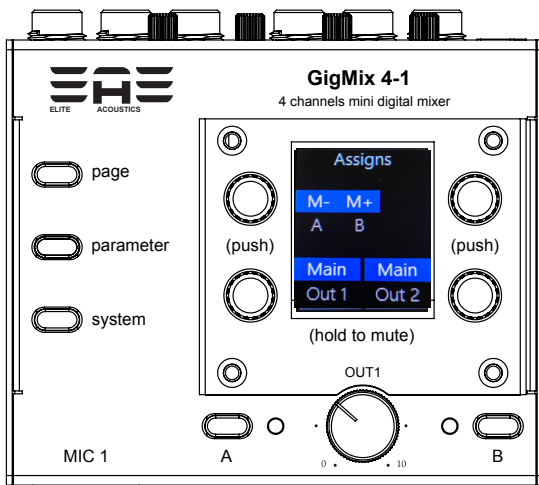

USE the corresponding Encoder knob for these Functions.

Assign "A" and "B" switches

"Assigns"

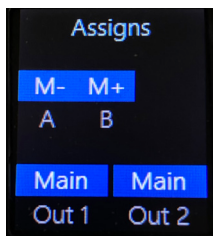

"Assigns"

"A" - Memory DOWN

"B" - Memory UP

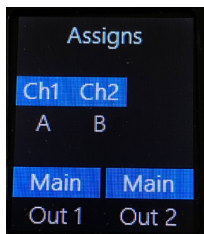

"A" -- CHAN 1 ON/OFF

"B" -- CHAN 2 ON/OFF

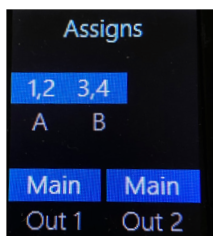

"Assigns"

"A" - CHAN 1/2 ON/OFF

"B" - CHAN 3/4 ON/OFF

"Assigns"

"A" -- Reverb ON/OFF

**"B" -- Delay TAP
"B" LED will flash, - Delay can be turn on/off by HOLD down the "B"**

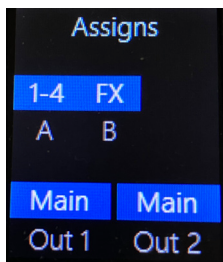
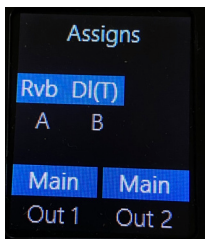

"Assigns"

"A" - all CHAN ON/OFF

"B" - EFX ON/OFF

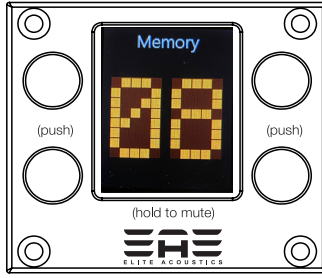

USE the corresponding Encoder knob for these Functions.
Assign “OUT1” and “OUT2” output routing

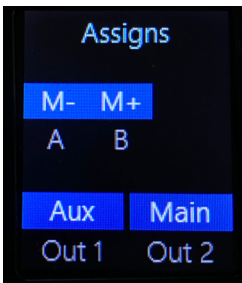

“Assigns”
 “AUX” Mix output to OUT1
 “MAIN” Mix output to OUT2

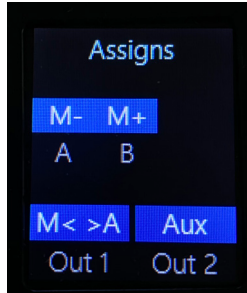

“Assigns”
 “MAIN” Mix MON and “AUX Mix MONO output to OUT1 (L/R)
 “AUX” Mix output OUT2

“Assigns”

OUT1 and OUT 2 routing are selectable from 3 separate output mix.



Main MIX



Aux Mix



Main Mix MONO - LEFT
 Aux Mix MONO - Right

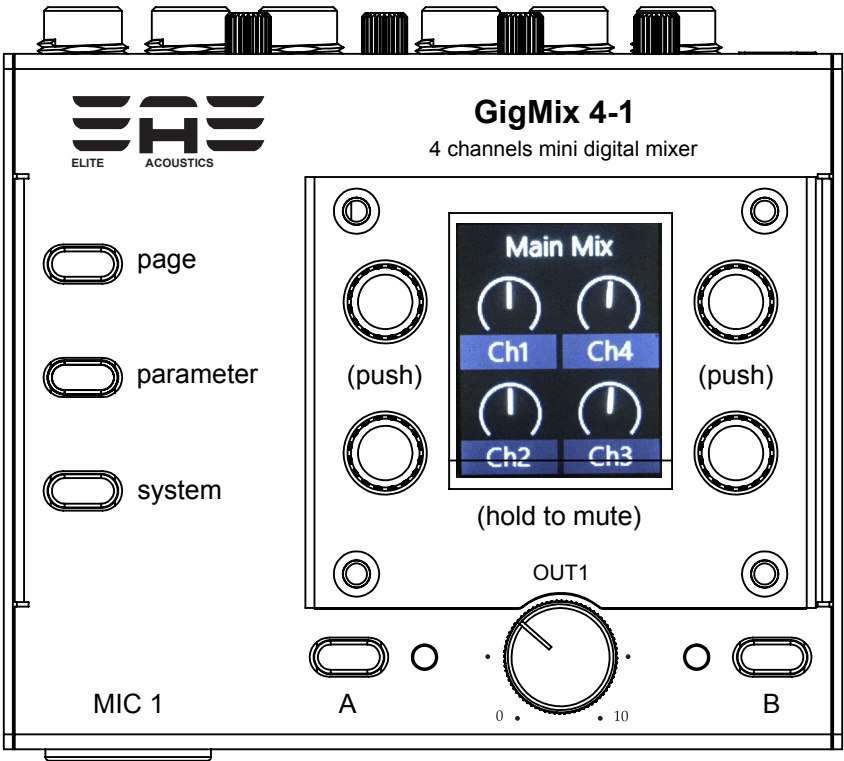

Output level Analog control. “post digital control”

OUT 1 - Level Control

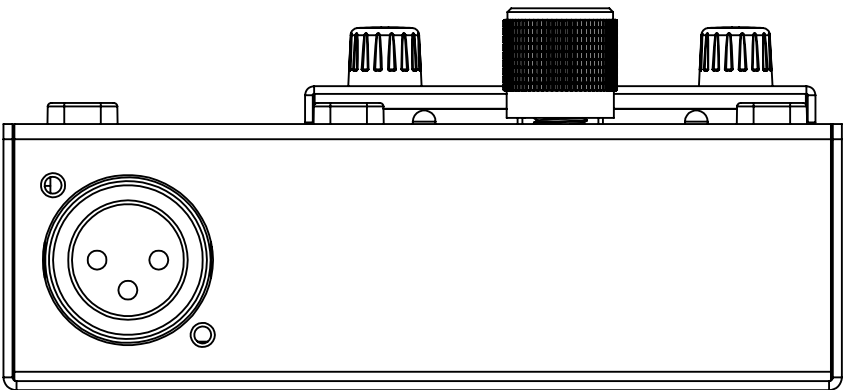

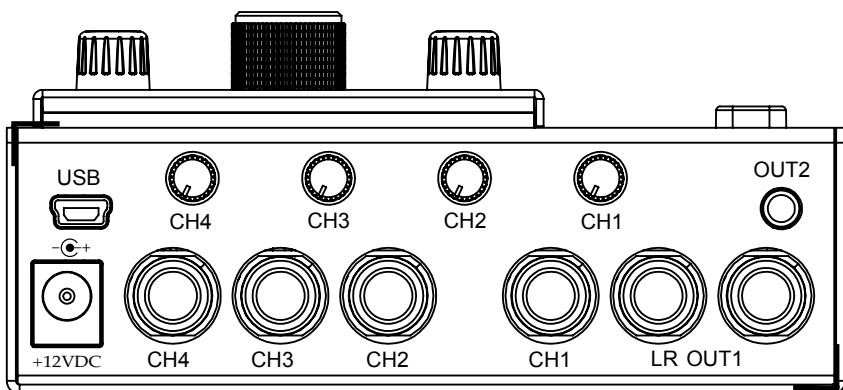

Rear Panel.

- 1) USB mini jack (for Updating unit.)
- 2) DC input Jack (+12VDC Center Positive.)
unit will operate from +9VDC to +12VDC with 400mA minimum.
- 3) CHAN 4 LEVEL and INPUT jack
- 4) CHAN 3 LEVEL and INPUT jack
- 5) CHAN 2 LEVEL and INPUT jack
- 6) CHAN 1 LEVEL and INPUT jack (MIC jack on Front)
- 7) OUT2 - 1/8" TRS jack
- 8) OUT1 - Left and Right outputs

SYSTEM SPECIFICATIONS

- **System Architecture** : Ultra high-speed high-capacity DSP with lossless A/D and D/A conversion. Integrated Digital Mixer supports routing and seamless signal-level management for four fully configurable audio channels. Color Graphic LCD presents a highly intuitive GUI for settings and save & recall.
 - **Digital Effects and Controls**: Channel Parametric EQ, Notch Filter, Selectable HiPass/Notch Filter, Compressor, Noise Gate, Main and Aux panning, Reverb, Delay, Real-Time Chan-Level Bar Graphs, Save & Recall Programs.
 - **Switch “A” and “B”** - Assignable functions include Memory Up/Down, Mutes, Reverb bypass and Tap Delay.
 - **Chan 1 (front panel)- MIC Inputs: XLR balanced**
 - .Chan 1 - (rear panel) TRS input balance Line input
 - .Chan 1 - TRS input impedance - 20K ohm.
 - **Chan 2, 3, 4 - TS Inputs: 1/4” input jacks**
 - .Chan 2, 3, 4 - TS input jack impedance: 1M ohm
 - **Displays**: Color Graphic LCD;
 - **Nominal output levels (1 kHz)**:
 - Output 2 - 1/8” TRS jack (-10dbu) Tip - Left, Ring - Right
 - Output 1 - 1/4” TRS L/R outputs BALANCED (+4dbr)
- Frequency Response - +/-1db 40Hz - 19Khz
- Power supply - DC in jack
- **Power Supply**: DC 12V 400mA or Higher - Included
 - **Current Draw**: 400 mA
 - **Accessories**: AC cord, AC adaptor, Owner’s manual
 - **Dimensions**: 4.38”W x 3.62”D x 1.58”H (111mmWx92mmDx41mmH)
 - **Weight**: 1 lbs

Product specifications subject to change without notice.

For most updated details, please visit: www.eliteacoustics.com or contract us via email.



Legal Notice: CALIFORNIA PROPOSITION 65 WARNING
WARNING: Cancer and Reproductive Harm - www.P65Warnings.ca.gov.

THIS DEVICE COMPLIES WITH PART 15 OF THE FCC RULES. OPERATION IS SUBJECT TO THE FOLLOWING TWO CONDITIONS.

1. THIS DEVICE MAY NOT CAUSE HARMFUL INTERFERENCE, AND
2. THIS DEVICE MUST ACCEPT ANY INTERFERENCE RECEIVED, INCLUDING INTERFERENCE THAT MAY CAUSE UNDESIRED OPERATION.

WARRANTY (USA ONLY)

Elite Acoustics Engineering Inc. warrants this product to be free of defects in material and workmanship (excluding battery) for a period of 1 year from the date of original retail purchase. Elite Acoustics Engineering Inc. warrants the Speaker's Battery for 90 days from the date of original retail purchase. This warranty is enforceable only by the original retail purchaser. To be protected by this warranty, the purchaser must complete and return the enclosed warranty card within 14 days of purchase. During the warranty period EAE shall, as its sole and absolute option, either repair or replace, free of charge, any product that proves to be defective on inspection by EAE or its authorized service representative. To obtain warranty service, contact Elite Acoustics Engineering Technical Support via email: RMA@eliteacoustics.com. PRE-AUTHORIZATION MUST BE OBTAINED BEFORE SENDING ANY PRODUCT TO AN ELITE ACOUSTIC ENGINEERING SERVICE CENTER. All inquires must be accompanied by a description of the problem. All authorized returns must be sent to the EAE repair facility postage prepaid, insured and properly packaged. EAE reserves the right to update any unit returned for repair. EAE reserves the right to change or improve the design of the product at any time without prior notice. This warranty does not cover claims for damage due to abuse, neglect, alteration, or attempted repair by unauthorized personnel and is limited to failures arising during normal use that are due to defects in material or workmanship in the product. Any implied warranties, including implied warranties of merchantability and fitness for a particular purpose, are limited in duration to the length of this limited warranty. Some states do not allow limitations on how long an implied warranty lasts, therefore above limitation may not apply to you. In no event will EAE be liable for incidental, consequential, or other damages resulting from the breach of any express or implied warranty, including among other things, damage to property, damage based on inconvenience or on loss of use of the product, and, to the extent permitted by law, damages for personal injury. Some states do not allow the exclusion of limitation of incidental or consequential damages, so the above limitation or exclusion may not apply to you. This warranty gives you specific legal rights, and you may also have other rights, which vary from state to state. This warranty only applies to products sold and used in the United States of America. For warranty information in all other countries please refer to your local distributor.

©Elite Acoustics Engineering Inc.

Outside of the USA - Contact the Distributor in your area for service and warranty info.