

# *Greenline HE*

## *C6-C11 E6-E11*

*1x230V*

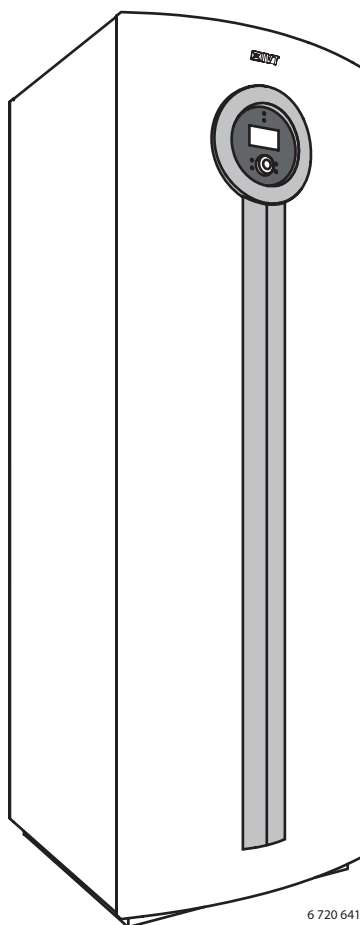

6 720 641 855-01.11

## **Installer Guide**

6 720 802 419 (2012/06) en



## **Information**

The IVT Greenline HE series is equipped with the latest generation low energy circulation pumps on both the cold and hot sides. This enables the further reduction of electricity consumption, which lowers your heating costs even more.

The installation of heat pumps for heat extraction from bedrock, ground or lake water is subject to compulsory registration. Contact the local government environmental and health protection office.

When purchasing the equipment, the dealer/installation engineer must make an energy estimate and assess the degree of energy coverage for the heat pump system.

## List of contents

<b>1</b>	<b>Key to symbols and safety instructions</b>	<b>5</b>	<b>10</b>	<b>Electrical connections</b>	<b>32</b>
1.1	Explanation of symbols	5	10.1	Connecting the heat pump	32
1.2	Safety instructions	5	10.2	Soft starter	32
<b>2</b>	<b>Included in the delivery</b>	<b>6</b>	10.3	Electrical connection wiring diagram	33
<b>3</b>	<b>General</b>	<b>7</b>	10.4	External connections	38
3.1	Information about the heat pump	7	10.5	Connection groundwater pump	38
3.2	Application area	7	10.6	Combined operation of two heat pumps (cascade connection)	39
3.3	Type overview	7	<b>11</b>	<b>Control panel</b>	<b>40</b>
3.4	Type plate	7	11.1	Panel overview	40
3.5	Transport and storage	7	11.2	On/Off button	40
3.6	Positioning the heat pump	7	11.3	Status lamp	40
3.7	Checks before installation	7	11.4	Menu display	40
3.8	Checklist	7	11.5	Menu button and menu dial	40
3.9	CAN-BUS	8	11.6	Return button	40
3.10	Handling circuit boards	9	11.7	Mode button	40
<b>4</b>	<b>Heating, general</b>	<b>10</b>	11.8	Info button	40
4.1	Circuits for heating	10	<b>12</b>	<b>Start up</b>	<b>41</b>
4.2	Control methods for heating	10	<b>13</b>	<b>Function check</b>	<b>42</b>
4.3	Time control for heating	10	13.1	Refrigerant circuit	42
4.4	Operating modes	10	13.2	Filling pressure in collector circuit	42
<b>5</b>	<b>Energy metering</b>	<b>11</b>	13.3	Setting heating system operating pressure	42
<b>6</b>	<b>Dimensions and clearance</b>	<b>12</b>	13.4	Operating temperatures	42
6.1	C6 - C11	12	<b>14</b>	<b>Installer menus</b>	<b>43</b>
6.2	E6 - E11	13	14.1	Access to the functions on Installer level	43
<b>7</b>	<b>Technical information</b>	<b>14</b>	14.2	CANbus LCD	43
7.1	Component parts	14	14.3	Compressor fast restart	43
7.2	System solutions	15	14.4	Temperature sensor	43
7.3	Technical information	21	<b>15</b>	<b>Menu overview</b>	<b>44</b>
<b>8</b>	<b>Regulations</b>	<b>25</b>	<b>16</b>	<b>Settings</b>	<b>48</b>
<b>9</b>	<b>Installation</b>	<b>26</b>	16.1	Room temperature	48
9.1	Collector system	26	16.2	Hot water	54
9.2	Heating system	28	16.3	Holiday	56
9.3	Siting the appliance	28	16.4	Energy measurements	56
9.4	Pipework preparations	28	16.5	Timers	57
9.5	Flushing out the heating system	28	16.6	External control	57
9.6	Setting up	28	16.7	Installer	58
9.7	Heat insulation	28	16.8	Additional heat	61
9.8	Removing the front panel	29	16.9	Safety functions	63
9.9	Temperature sensor installation	29	16.10	General	63
9.10	Filling the heating system	30	16.11	Alarms	64
9.11	Filling the collector system	30	16.12	Access level	64
			16.13	Return to factory settings	64

---

<b>17 Alarms</b>	<b>65</b>
17.1 Alarms	65
17.2 Control unit and room sensor alarm lamp	65
17.3 Alarm display	65
17.4 Alarm buzzer at alarm	65
17.5 Acknowledgement of alarms	65
17.6 Alarm timer, alarm mode	65
17.7 Alarm categories	66
17.8 Alarm window	66
17.9 Alarm functions	67
17.10 Alarm log	71
17.11 Alarm history	71
17.12 Information log	72

---

<b>18 Factory settings</b>	<b>73</b>
18.1 Return to factory settings	73
18.2 Factory values	73

---

<b>19 Environmental protection</b>	<b>76</b>
------------------------------------	-----------

---

<b>20 Maintenance</b>	<b>77</b>
-----------------------	-----------

---

<b>21 Commissioning protocol Greenline HE</b>	<b>78</b>
---	-----------

---

# 1 Key to symbols and safety instructions

## 1.1 Explanation of symbols

### Warning symbols

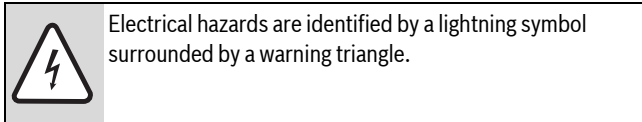
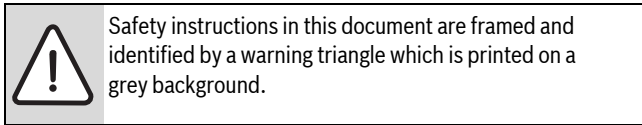

Signal words indicate the seriousness of the hazard in terms of the consequences of not following the safety instructions.

- **NOTICE** indicates possible damage to property or equipment, but where there is no risk of injury.
- **CAUTION** indicates possible injury.
- **WARNING** indicates possible severe injury.
- **DANGER** indicates possible risk to life.

### Important information

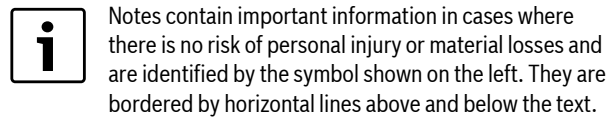

### Additional symbols

Symbol	Meaning
▶	a step in an action sequence
→	a reference to a related part in the document or to other related documents
•	a list entry
–	a list entry (second level)

Table 1

## 1.2 Safety instructions

### General

- ▶ Read the guide carefully and keep it to hand for future use.

### Installation and commissioning

- ▶ The heat pump may be installed and put into operation only by a qualified installer.

### Service and maintenance

- ▶ Only qualified personnel may carry out repairs. Incorrect repairs can lead to serious risks to the user, and a reduction in savings.
- ▶ Only use original spare parts.
- ▶ Service and maintenance must be carried out annually by an authorised service representative.

## 2 Included in the delivery

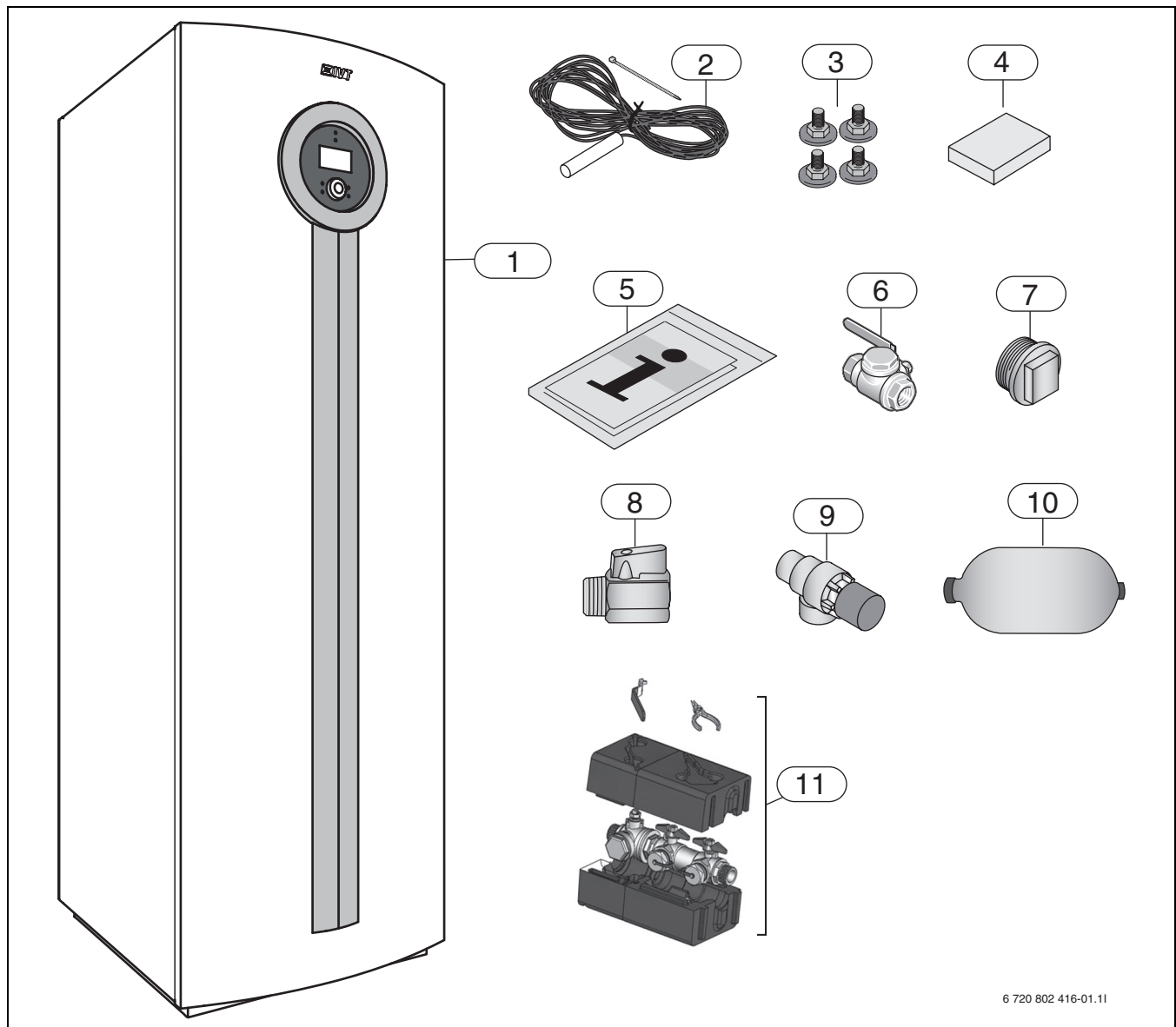

6 720 802 416-01.11

Fig. 1

- [1] Heat pump
- [2] Flow sensor
- [3] Adjustable feet
- [4] Outdoor sensor
- [5] Document set
- [6] Particle filter (R 3/4 inner thread) for the heating system (C6-C11)
- [7] Drain plug
- [8] Ball valve
- [9] Safety valve
- [10] Expansion vessel
- [11] Filling unit DN25 C6-C11, E6-E11

### 3 General



Only qualified installers may carry out the installation. The installer must follow applicable rules and regulations and recommendations from the supplier.

#### 3.1 Information about the heat pump

**C6-C11** are heat pumps with integrated hot water heaters.

**E6-E11** are heat pumps designed to be supplemented with an external hot water heater.

#### 3.2 Application area

The heat pump must only be used in a closed hot water heating system according to BS EN 12828.

Other forms of use are not permitted. We take no responsibility for damage occurring due to non-permitted use.

#### 3.3 Type overview

<b>C</b>	6	7	9	11
<b>E</b>	6	7	9	11

Table 2 Type overview

- [C] Heat pump (with integrated hot water heater)
- [E] Heat pump (without integrated hot water heater)
- [6-11] Heating output 6...11 kW

#### 3.4 Type plate

The type plate is located on the roof plate of the heat pump. Information about the heat pump's output, part number, serial number and date of manufacture is stated there.

#### 3.5 Transport and storage

The heat pump should always be transported and stored in an upright position. However, the heat pump may be tilted temporarily, but must not be laid down.

The outer cover plates should be removed to avoid damage if the heat pump is transported without the supplied transport pallet.

The heat pump must not be stored at below zero temperatures.

#### 3.6 Positioning the heat pump

- ▶ The heat pump is placed indoors, on a level and stable surface that withstands a weight of at least 500 kg.
- ▶ Adjust the rubber feet so the heat pump does not lean.
- ▶ The ambient temperature around the heat pump must be between +10 °C and +35 °C.
- ▶ The installer should take sound propagation into consideration when positioning the heat pump.
- ▶ Make sure there is a floor drain in the room where the heat pump is installed.

#### 3.7 Checks before installation

- ▶ Installation of the heat pump should be performed by a qualified installer.
- ▶ Before the heat pump is commissioned, the heating system, hot water cylinder and the collector circuit system, including the heat pump, must be filled and vented.
- ▶ Check that all pipe connections are intact and have not shaken loose during transportation.
- ▶ Wiring should be kept as short as possible to protect the system from downtime, for example during a thunderstorm.
- ▶ Heat pump installation, energy drilling and collector installation must follow applicable regulations.

#### 3.8 Checklist



Each heat pump installation is unique. The following checklist will give you a general description of how the installation should be carried out.

1. Position the heat pump on an even base. Adjust the height using the adjustable feet.
2. Install the incoming and outgoing pipes for the heat pump, as well as the expansion vessel.
3. Fit the filling unit, particle filters and valves.
4. Connect the heating unit to the heating system.
5. Install the outdoor sensor and possible room sensors.
6. Fill and vent the heating and collector systems before commissioning.
7. Carry out the external connections.
8. Connect the heating installation to the power supply.
9. Commission the heating installation by making all the necessary settings on the control panel.
10. Check the heating installation after commissioning.
11. Top up more collector circuit fluid, if required.

### 3.9 CAN-BUS

The various circuit boards in the heat pump are joined by a communications cable, CAN-BUS. CAN (Controller Area Network) is a two-wire system for communication between microprocessor based modules/circuit boards.

**CAUTION:** Interference.

- ▶ The CAN-BUS cable must be screened and laid separately from the power cable.

A suitable cable for external laying is cable ELAQBY/LIYCY (TP) 2x2x0.5. The cable must be twisted pair type and screened. The screen must only be earthed at one end and to the chassis.

Maximum cable length is 30 m.

CAN-BUS cable must **not** be laid alongside power supply cables. Minimum distance 100 mm. They may be laid alongside sensor cables.

**CAUTION:** Do not mix up the 12V and CAN-BUS connections!

The processors are destroyed if 12V is connected to the CAN-BUS.

- ▶ Check that the four cables are connected to the contacts with the corresponding marking on the circuit board.

The connection between the circuit boards is by four wires, because the 12V-supply between the circuit boards must also be connected. The circuit boards have markings for both the 12V and CAN-BUS connections.

**Switch Term** is used to mark the start and end of a CAN-BUS loop. Ensure that the correct circuit board is terminated and that all other switches are in the opposite position.

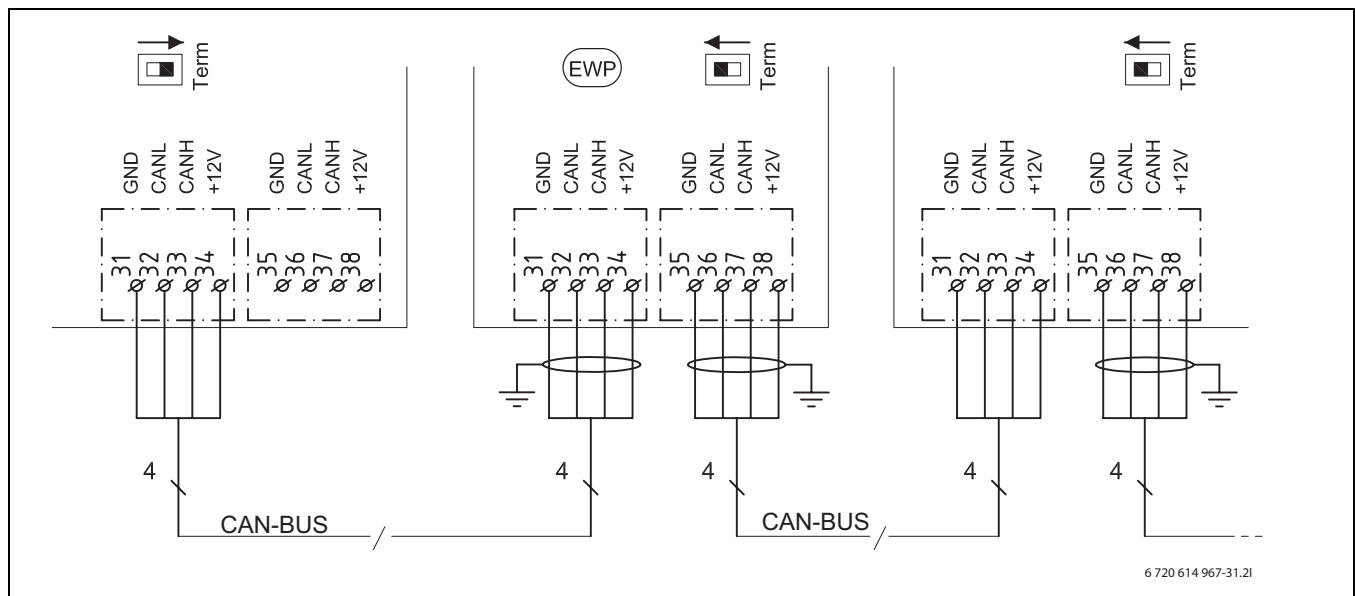



Fig. 2

- [GND] Earth
- [CANL] CAN low
- [CANH] CAN high
- [+12V] Connection 12V
- [EWP] Heat pump



### 3.10 Handling circuit boards

Circuit boards with control electronics are sensitive to discharges of static electricity (ESD – ElectroStatic Discharge) when handled. To prevent damaging the components, special care is therefore required when handled.

 **CAUTION:** Never grasp a circuit board without wearing a ground-connected bracelet.

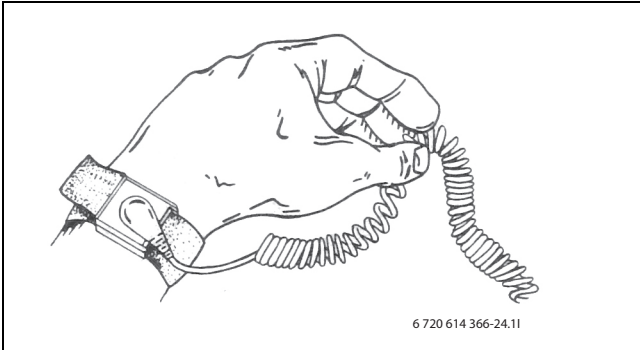

Fig. 3 Bracelet

Damage is usually latent, and a circuit board can operate impeccably during commissioning but show signs of problems later. Charged objects may only be problematic if they are in close proximity to the electronics. Keep a distance of at least one metre from expanded polystyrene, protective plastic and other packaging, synthetic material (e.g. fleeces) and similar before starting work.

A condition for good ESD protection is a ground-connected bracelet when handling electronics. This bracelet must be put on before opening the screened metal bag/packaging or before exposing an installed board. The bracelet must be worn until the circuit board is enclosed in its screen packaging or closed electric box. Replaced, returned circuit boards must be handled in the same way.

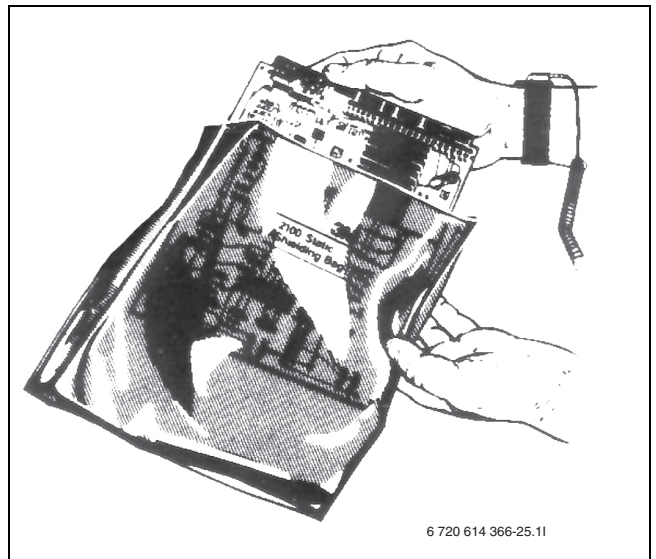

Fig. 4

## 4 Heating, general

The heating system consists of one or more circuits; these may also have a cooling function (option). The heating system is installed according to operating mode, depending on access to and type of addition. Settings for this are made by the installer

### 4.1 Circuits for heating

- **Circuit 1;** the first circuit is included by default in the control unit and is controlled by the installed flow sensor, possibly in combination with an installed room sensor.
- **Circuit 2 (mixed);** control of circuit 2 is also included by default in the control unit and only needs to be supplemented with a mixing valve, circulation pump and flow sensor and possibly with an additional room sensor.
- **Circuits 3-4 (mixed);** control of up to 2 additional circuits is optional. Each circuit is then fitted with a Multi module, mixing valve, circulation pump, flow sensor and possibly a room sensor.



Circuits 2 through 4 cannot have a higher flow temperature than circuit 1. This means that underfloor heating on circuit 1 cannot be combined with radiators on another circuit. Room temperature reduction for circuit 1 can affect other circuits in some cases.

### 4.2 Control methods for heating

- **Outdoor sensor;** a sensor is fitted on the outside wall of the house. The sensor sends signals to the control unit in the heat pump. Control with an outdoor sensor means that the heat pump automatically regulates the heating in the house depending on the outdoor temperature. The customer determines the temperature of the heating system in relation to the outdoor temperature by setting the current room temperature in the control unit.
- **Outdoor sensor and room sensors** (one room sensor per circuit is possible); Control with outdoor sensor supplemented with room sensor(s) means that one (or several) sensors are mounted in a central location inside the house. They are connected to the heat pump and provide the control unit with information about the current room temperature. The signal affects the flow temperature. For example, it falls when the room sensor indicates a higher temperature than the one set. Room sensors are used when factors other than the outdoor temperature influence the indoor temperature of the house. For example, this can be when a stove or fan-assisted radiator is used in the house, or if the house is sensitive to the wind or exposed to direct sunlight.



It is only the room where the room sensor is located that can influence regulation of the temperature for the relevant heating circuit.

### 4.3 Time control for heating

- **Program control;** the control unit offers four fixed and two individual programs for clock setting of day/time.
- **Holiday;** the control unit has a program for holiday mode, which means that during the selected period the room temperature changes to a lower or higher level. The program also allows switching off hot water production.
- **External control;** the control unit can make settings for external control, which means that the preselected function is performed when the control unit senses an input signal.

### 4.4 Operating modes

- **With electrical additional heat;** the heat pump is dimensioned less than the house peak heating load and electrical additional heat is permitted to cut in at the same time as the heat pump to meet the demand, when the heat pump cannot meet it itself. Alarm mode, Extra hot water and Hot water peak, and if the heat pump is off at low outdoor temperatures, the addition is also activated.
- **With mixed additional heat (option);** mixed additional heat which is permitted to work at the same time as heat pump. The additional heat is also used during alarm operation. A hot water electric heater is required for production of extra hot water and hot water peak. In this case, the electric additional heat in the heat pump is disabled.



The Multi module accessory is required for mixed additional heat and hot water electric heater.

## 5 Energy metering

Energy metering in the heat pump is an approximation based on the sum of the nominal emitted output during the relevant metering period. The calculation requires for example that the heat pump is correctly installed, and that the flow and  $\Delta$  temperatures on the hot and cold sides are adjusted as recommended. The value should therefore be regarded as an estimate of the actual emitted output. The margin of error in the calculation is normally put at 5-10%.

In addition, the energy output is affected by the outdoor temperature, the settings for the thermostat and room controls and heat pump usage. Ventilation, indoor temperature and hot water demand can play a decisive role.

## 6 Dimensions and clearance

### 6.1 C6 - C11

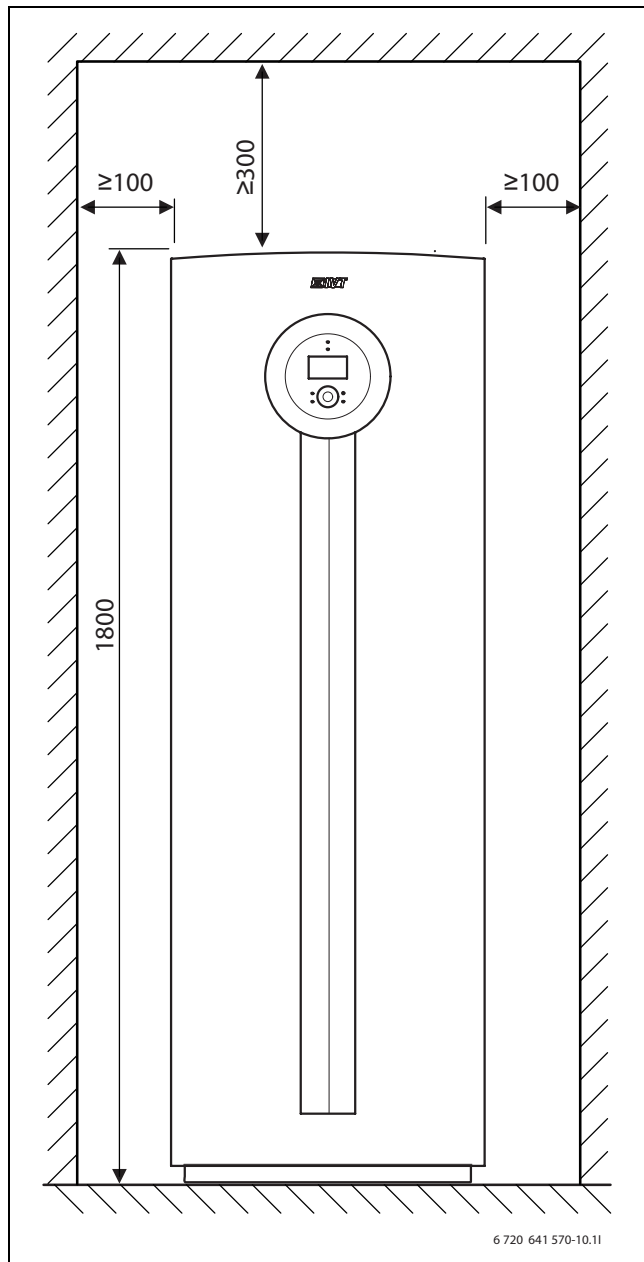

Fig. 5

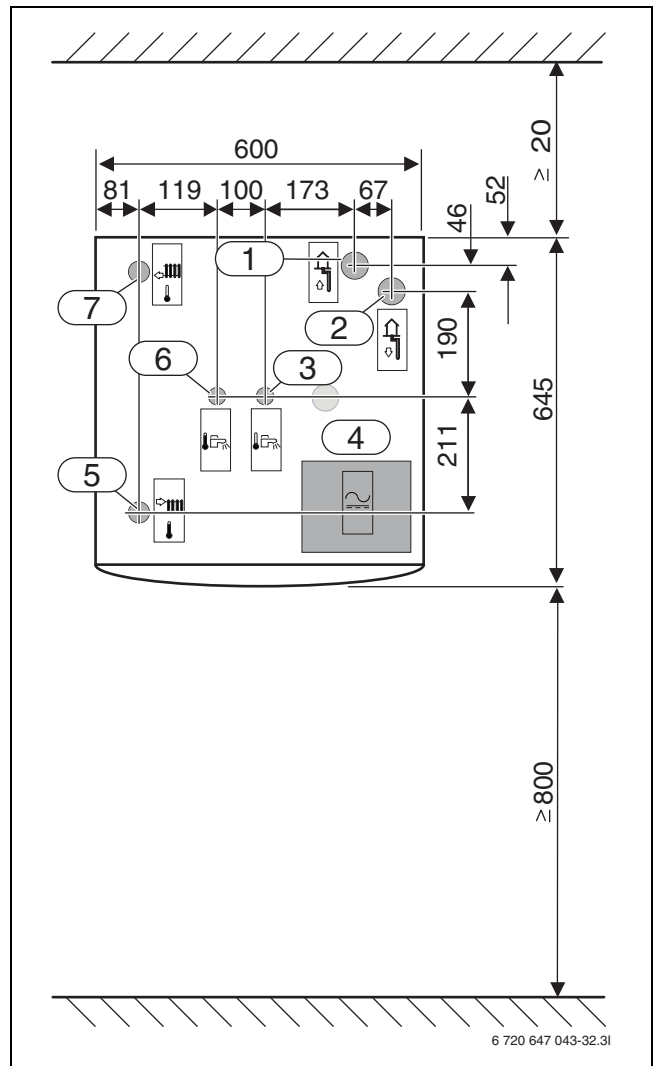

Fig. 6

**All dimensions are stated in mm.:**

- [1] Collector circuit in
- [2] Collector circuit out
- [3] Cold water in
- [4] Electrical connections
- [5] Flow heating system
- [6] Hot water out
- [7] Return heating system

6.2 E6-E11

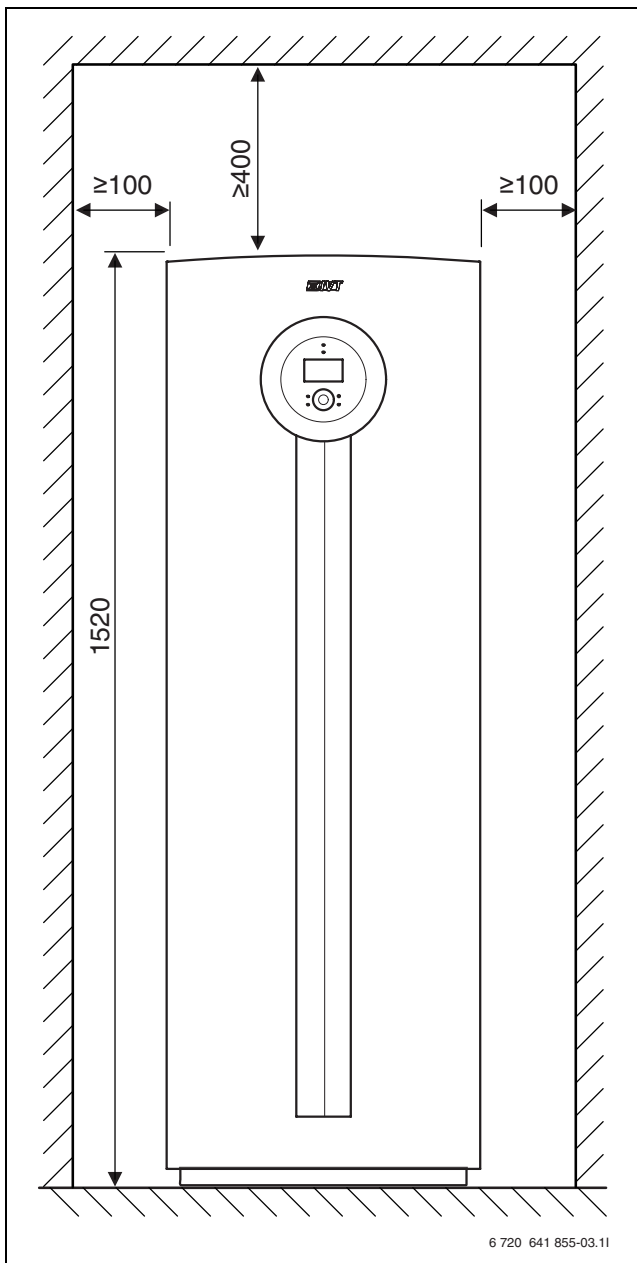

Fig. 7

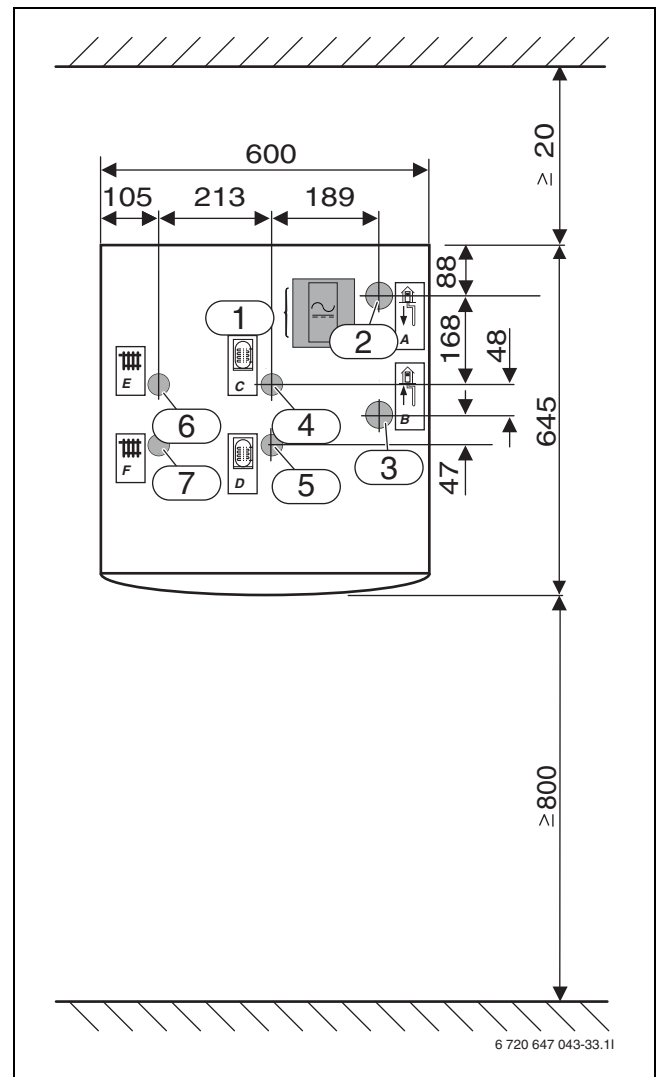

Fig. 8

All dimensions are stated in mm.:

- [1] Electrical connections
- [2] Collector circuit out
- [3] Collector circuit in
- [4] Return, hot water heater
- [5] Flow, hot water heater
- [6] Return heating system
- [7] Flow heating system

## 7 Technical information

### 7.1 Component parts

#### 7.1.1 C6 - C11

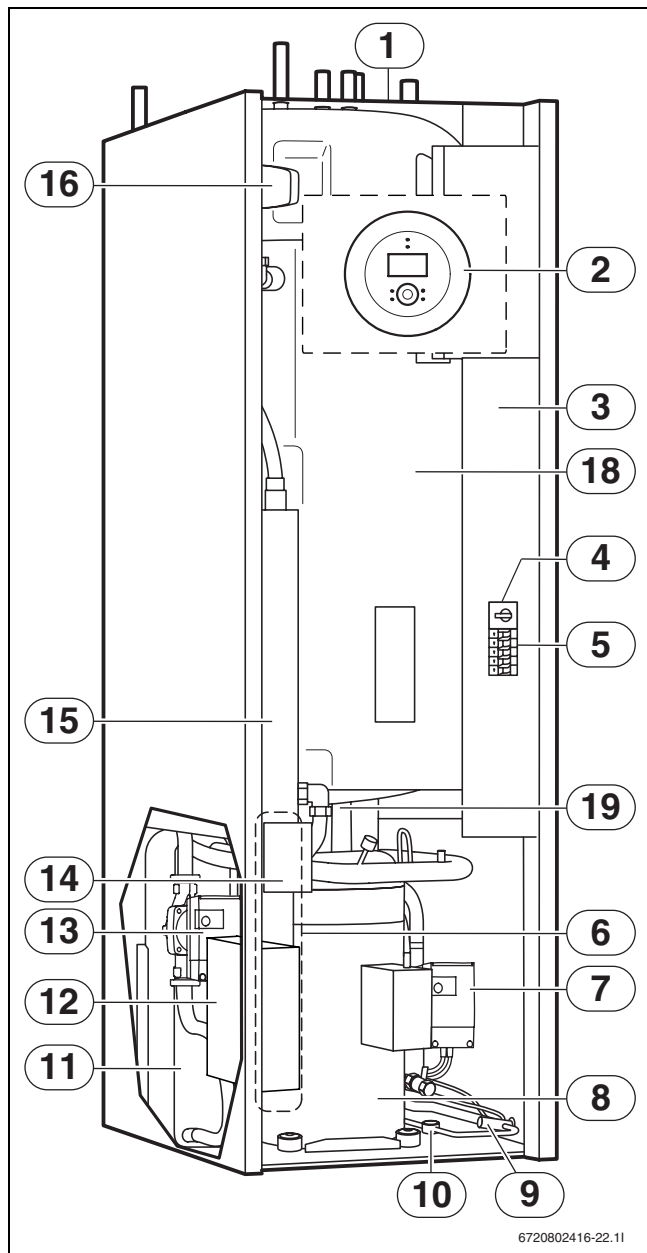

Fig. 9

- [1] Type plate
- [2] Control panel
- [3] Electric box
- [4] Motor cut-out with reset compressor
- [5] Miniature circuit breakers
- [6] Evaporator (concealed)
- [7] Collector circuit pump
- [8] Compressor with insulation
- [9] Expansion valve
- [10] Sight glass

#### 7.1.2 E6 - E11

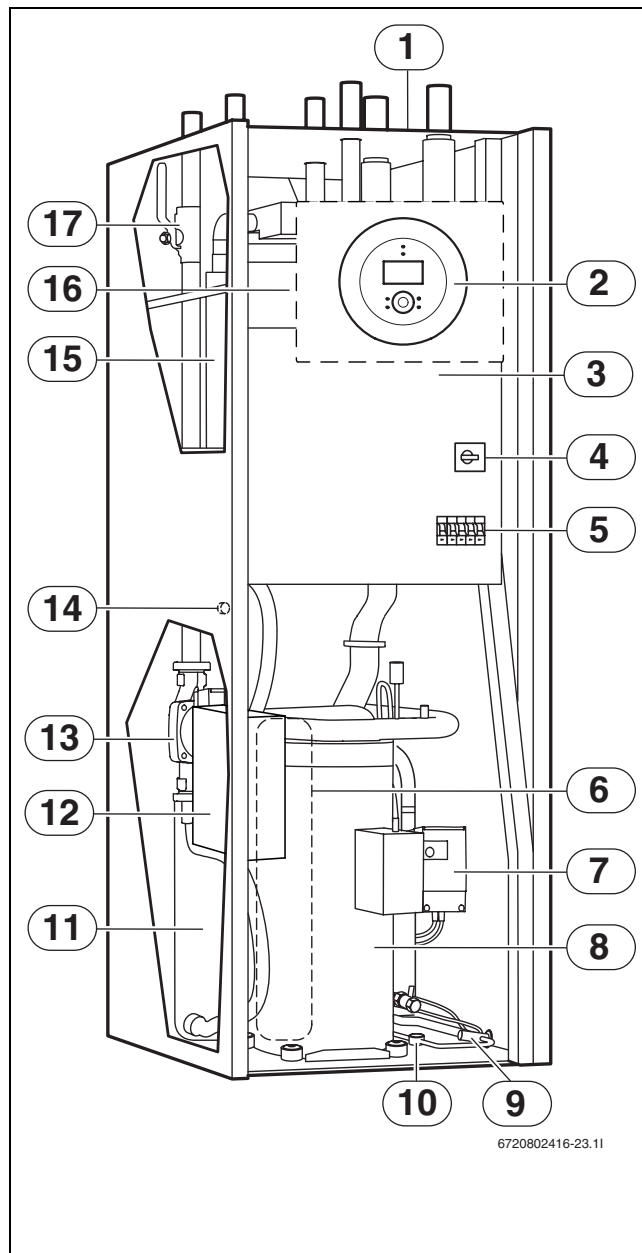

Fig. 10

- [11] Condenser
- [12] Soft starter
- [13] Heat carrier pump
- [14] Reset button for overheat protection to electric heater (hidden)
- [15] Electric additional heat
- [16] 3-way valve
- [17] Particle filter for the heating system
- [18] Double shelled hot water heater
- [19] Drain tap under the hot water heater

## 7.2 System solutions



Detailed system solutions can be found in the product's planning documentation.

### 7.2.1 System solution explanations

#### E10

E10.T2	Outdoor sensor
--------	----------------

Table 3 E10

#### E11

E11.C101	Expansion vessel
E11.C111	Buffer tank
E11.F101	Safety valve
E11.G1	Circulation pump, heating system
E11.P101	Pressure gauge
E11.T1	Flow sensor
E11.TT	Room sensor

Table 4 E11

#### E12

E12.G1	Circulation pump mixed circuit
E12.Q11	Mixing valve
E12.T1	Flow sensor
E12.T5	Room sensor

Table 5 E12

#### E21

E21	Heat pump
E21.E2	Electric additional heat
E21.F101	Safety valve
E21.G2	Heat carrier pump
E21.G3	Collector circuit pump
E21.Q21	3-way valve
E21.R101	Non-return valve
E21.T6	Hot gas sensor
E21.T8	Sensor Heat transfer fluid out
E21.T9	Sensor Heat transfer fluid in
E21.T10	Sensor Collector circuit in
E21.T11	Sensor Collector circuit out
E21.V101	Filter

Table 6 E21

#### E22

E22	Heat pump
E22.E2	Electric additional heat
E22.G2	Heat carrier pump
E22.G3	Collector circuit pump
E22.Q22	3-way valve
E22.R101	Non-return valve
E22.T6	Hot gas sensor
E22.T8	Sensor Heat transfer fluid out
E22.T9	Sensor Heat transfer fluid in
E22.T10	Sensor Collector circuit in
E22.T11	Sensor Collector circuit out
E22.V101	Filter

Table 7 E22

#### E31

E31.C101	Expansion tank
E31.F101	Safety valve
E31.P101	Pressure gauge
E31.Q21	Filler valve
E31.Q22	Filler valve
E31.Q23	Filler valve
E31.R101	Non-return valve
E31.R102	Non-return valve
E31.V101	Filter

Table 8 E31

#### E41

E41	Hot water cylinder
E41.E1	Electric additional heat
E41.F101	Safety valve
E41.F111	Automatic vent
E41.Q106	Shut off valve
E41.Q107	Shut off valve
E41.Q121	Non-return valve
E41.T3	Sensor, hot water
E41.V41	Hot water
E41.W41	Cold water

Table 9 E41

7.2.2 C6 - C11

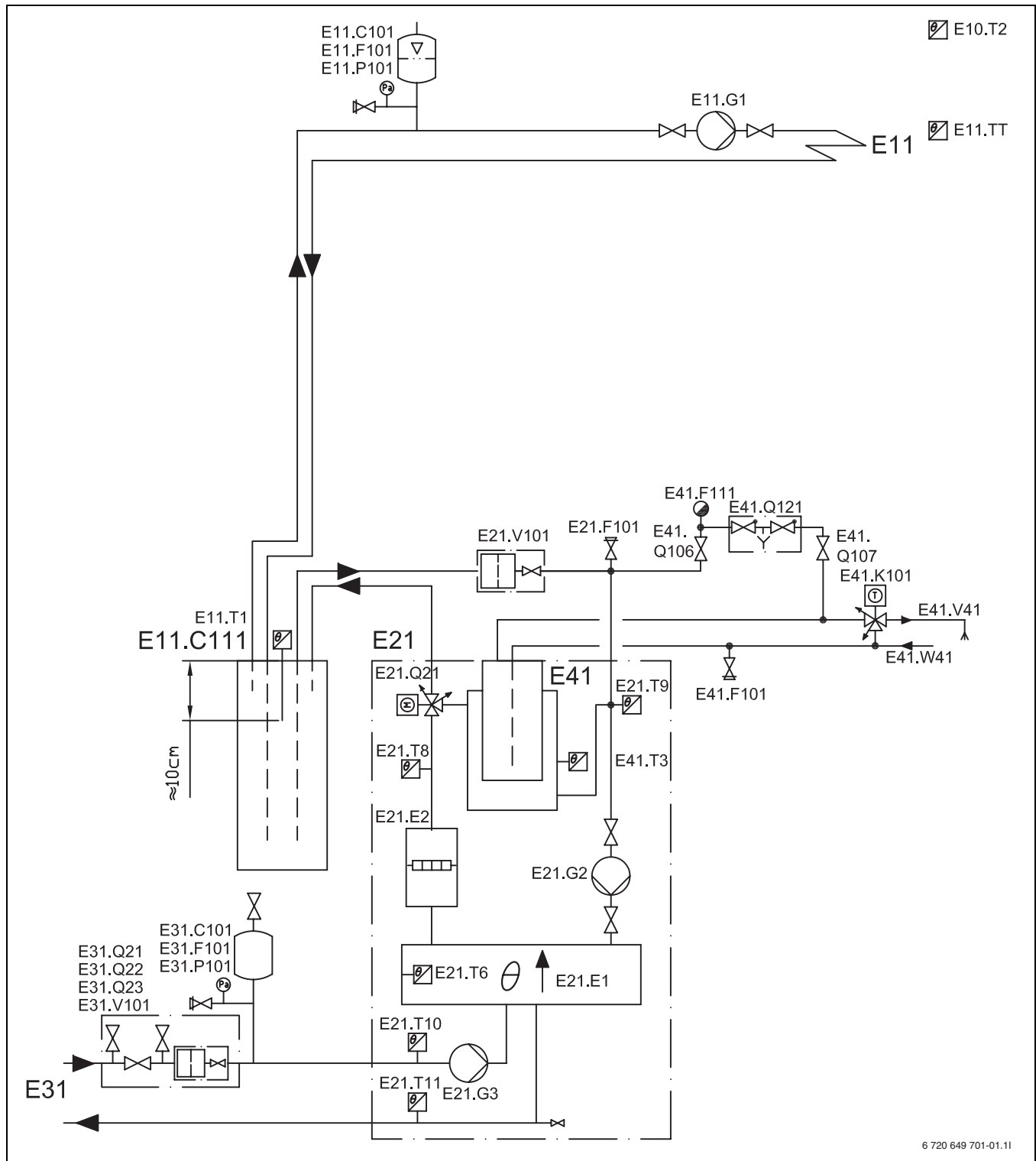

Fig. 11 Unmixed heating circuit with buffer tank

When installing to underfloor heating systems with individual room control, a system solution with a buffer tank (E11.C111) is required to guarantee the flow over the heat pump.



For explanations to the system solutions (→ 7.2.1 ).



7.2.3 C6 - C11

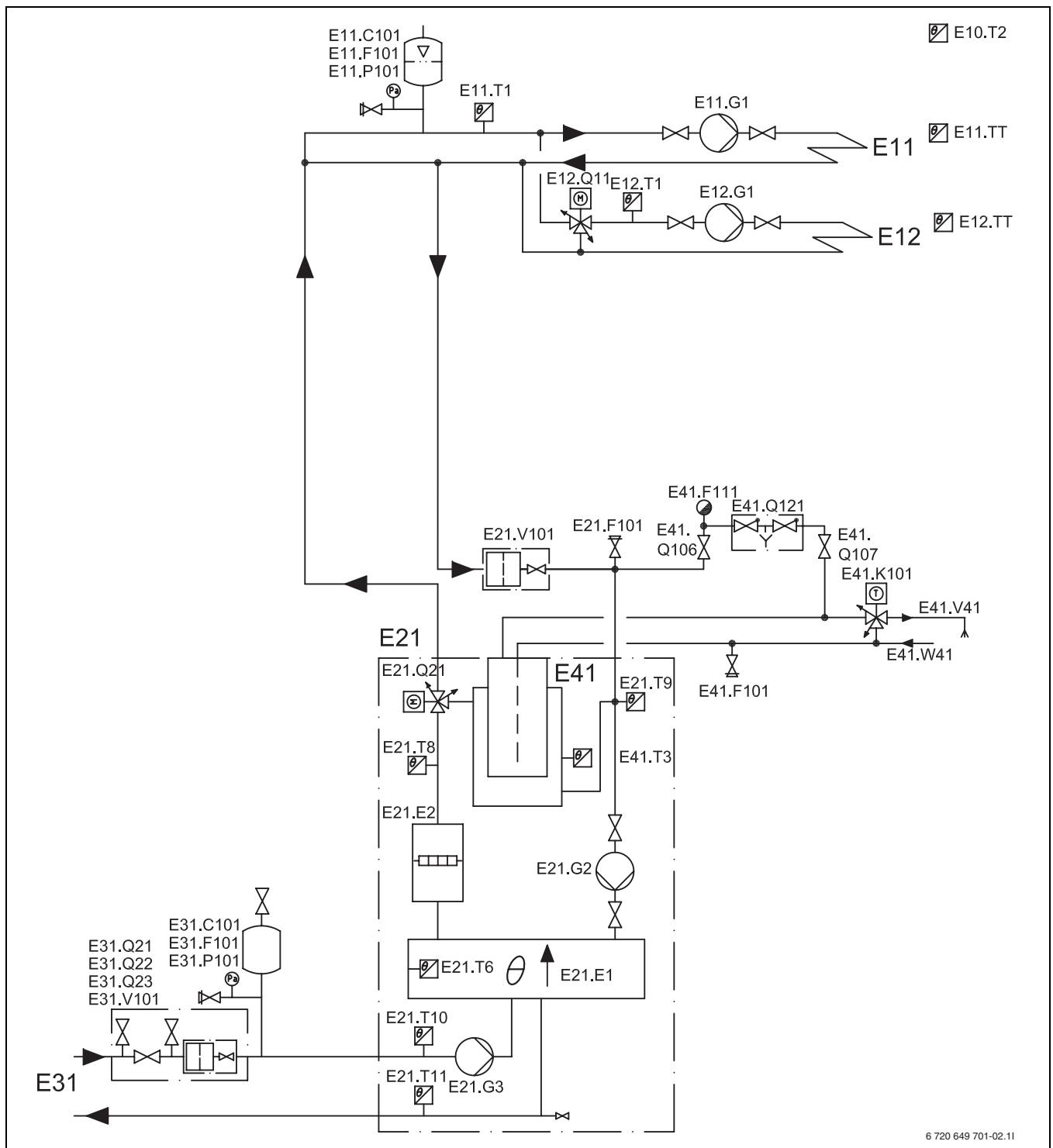



Fig. 12 Unmixed and mixed heating circuit

An absolute prerequisite for the connection is that a minimum flow of at least 70% of the nominal flow can be maintained throughout the year.

\* If a bypass is used and an external circulation pump is fitted, the flow over the heating system can be reduced by 40% of the nominal flow of the heat pump. Ensure that most of the thermostat valves are fully open. Otherwise an accumulator tank of at least 100 litres in capacity must be installed. The bypass length must be at least ten times that of the pipe's inner dimension.

 For explanations to the system solutions (→ 7.2.1 ).

7.2.4 E6-E11 (E13-E17)

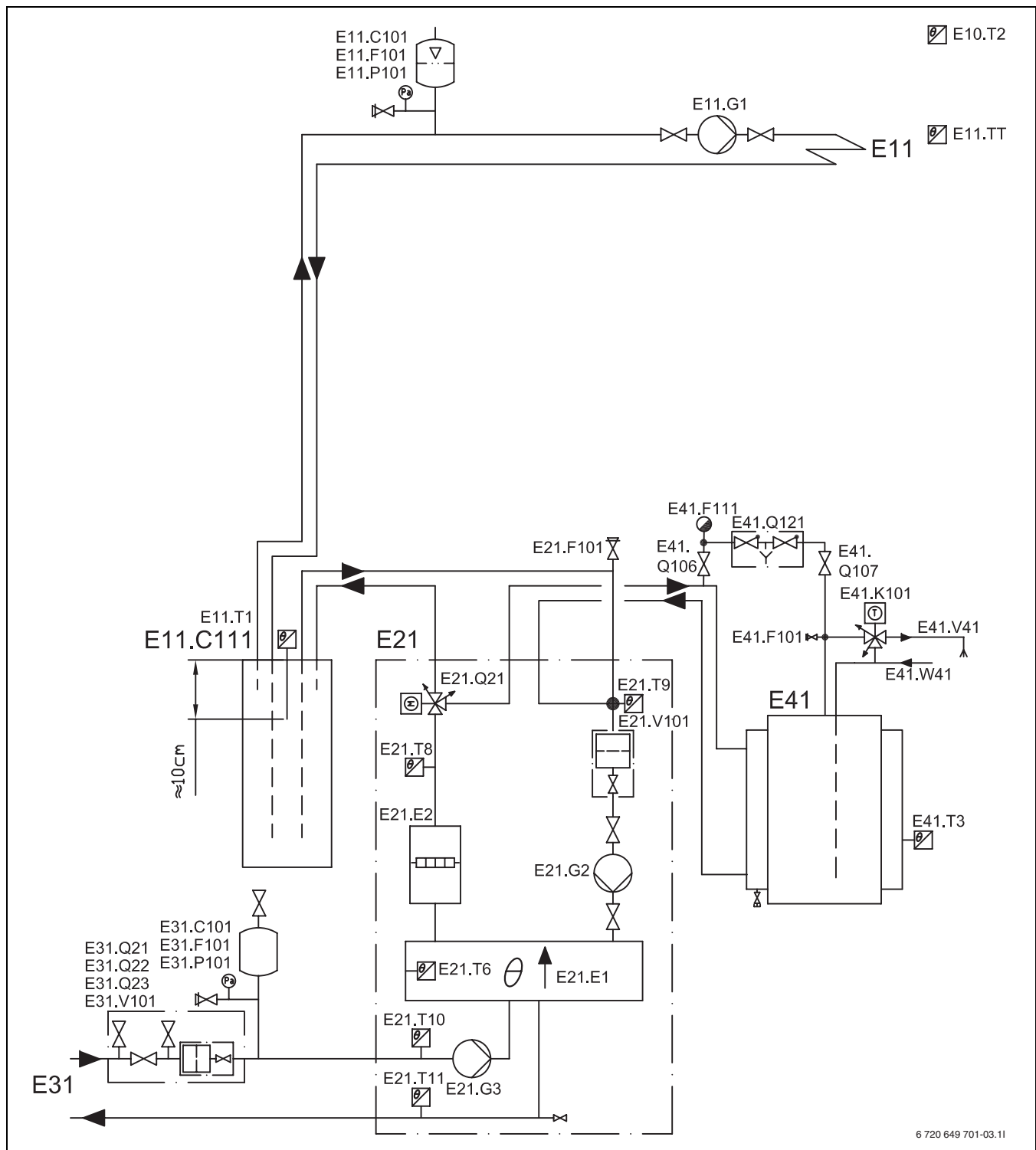

Fig. 13 Unmixed heating circuit with buffer tank and external hot water heating

When installing to underfloor heating systems with individual room control, a system solution with a buffer tank (E11.C111) is required to guarantee the flow over the heat pump.



For explanations to the system solutions (→ 7.2.1 ).

7.2.5 E6 - E11

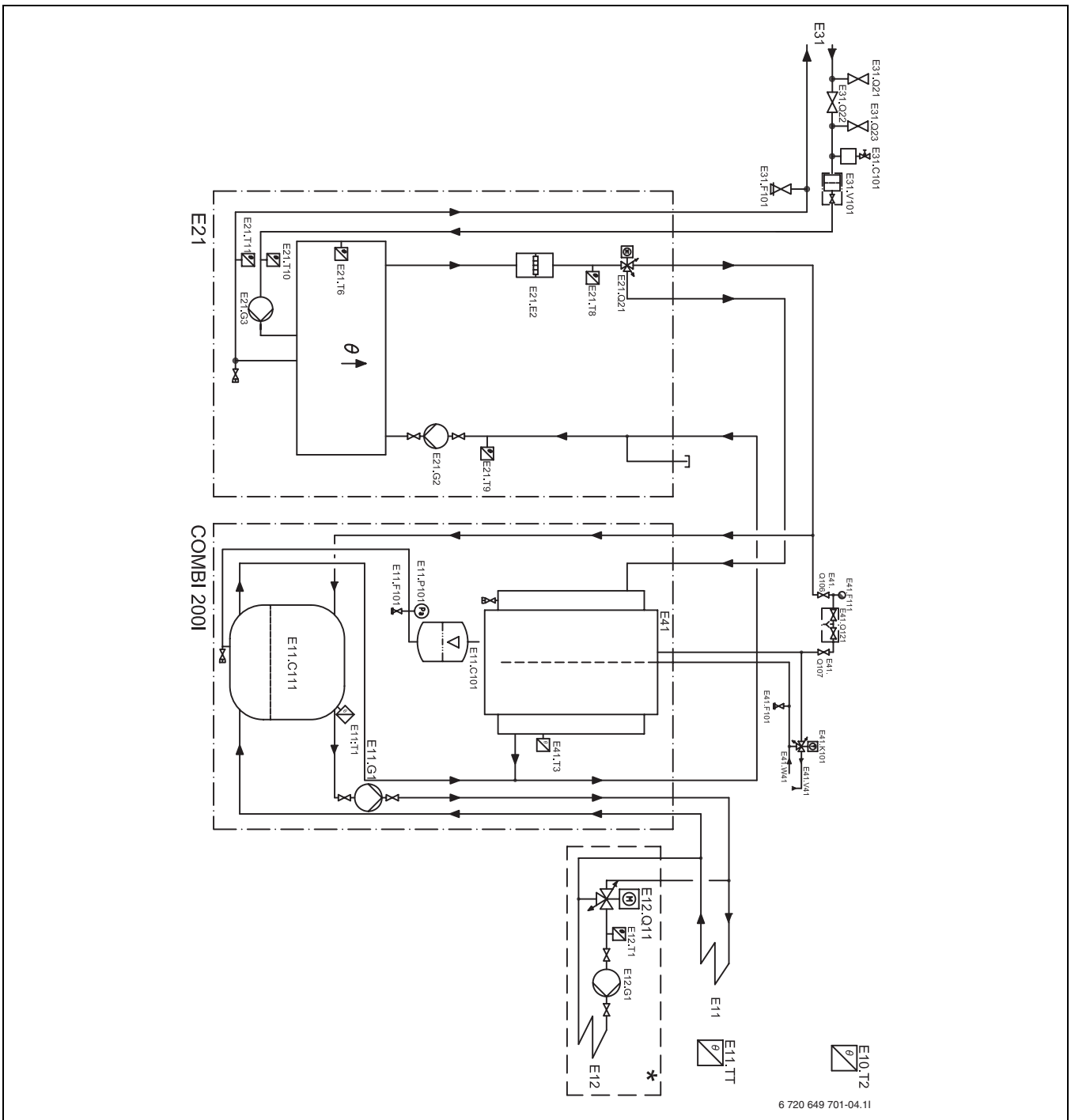

Fig. 14 Unmixed and mixed heating circuit with combi heater

When installing to underfloor heating systems with individual room control, a system solution with a buffer tank (E11.C111) is required to guarantee the flow over the heat pump.



For explanations to the system solutions (→ 7.2.1 ).



For more information about the combi heater (COMBI) see the Installation and conversion kit manual for the combi heater.

7.2.6 Combined operation of two heat pumps (cascade connection)

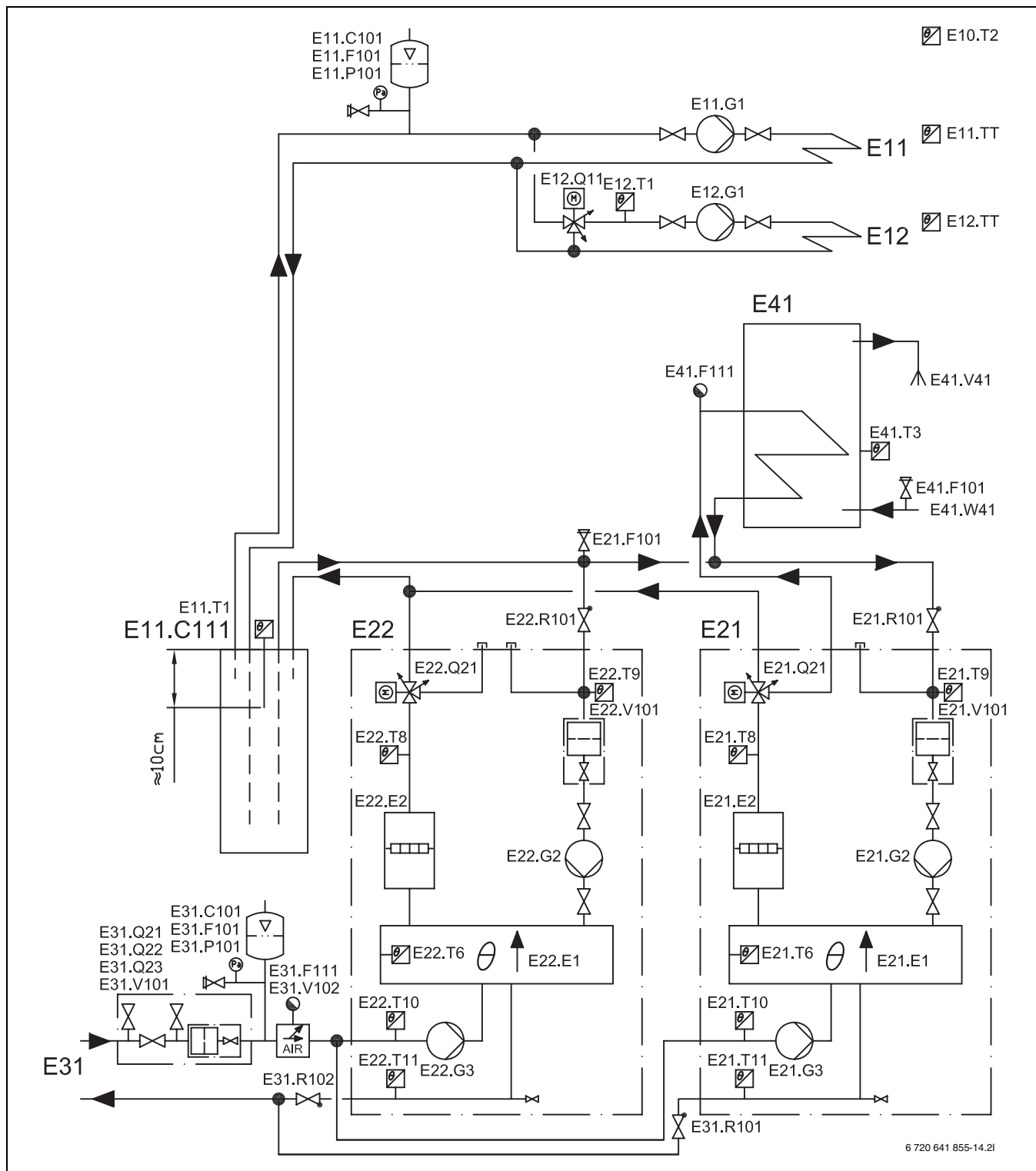

Fig. 15 Two heat pumps (cascade connection) with unmixed and mixed heating circuits, buffer tank and external hot water heater.



For explanations to the system solutions (→ 7.2.1 ).

## 7.3 Technical information

### 7.3.1 C6 - C11

	Unit	C6	C7	C9	C11
<b>Mode fluid/water</b>					
Heating output (B0/W35) <sup>1)</sup>	kW	5,0	6,6	8,7	10,2
Heating output (B0/W45) <sup>1)</sup>	kW	4,8	6,2	8,3	9,6
COP (B0/W35) <sup>1)</sup>	-	3,51	3,82	3,84	3,97
COP (B0/W45) <sup>1)</sup>	-	2,82	2,97	3,15	3,17
<b>Heat transfer fluid</b>					
Nominal flow (delta_T = 3K <sup>2)</sup> )	l/s	0,20	0,41	0,50	0,62
Permitted external pressure drop <sup>2)</sup>	kPa	47	43	80	91
Max. pressure	bar	4			
Contents (internal)	l	5			
Operating temperature	°C	-5... +20			
Connection (Cu)	mm	28			
<b>Compressor</b>					
Type	-	Mitsubishi scroll			
Weight cooling agent R 407c <sup>3)</sup>	kg	1,6	1,6	1,8	2,4
Max. pressure	bar	31			
<b>Heating system</b>					
Nominal flow (delta_T = 7K)	l/s	0,20	0,25	0,31	0,38
Min./max. flow temperature	°C	20/65			
Max. permitted operating pressure	bar	3			
Heating water incl. outer shell hot water heater	l	47			
Connection (Cu)	mm	22			
<b>Hot water</b>					
Max. output with/without electric additional heat (9kW)	kW	5,0/14,0	6,6/15,6	8,7/17,7	10,2/19,2
Volume hot water	l	185			
NL figure	-	1,0	1,2	1,5	1,8
Min./max. permitted operating pressure	bar	2/10			
Connection (stainless steel)	mm	22			
<b>Values for electrical connection</b>					
Electrical supply		230V 1N~50Hz			
Fuse, slow; with electric additional heat 3/6/9 kW	A	25/40/63	32/40/63	32/50/63	40/50/63
Nominal power consumption compressor (B0/W35)	kW	1,17	1,48	1,78	2,09
Max. current with soft starter	A	<35			
Enclosure class	IP	X1			
<b>General</b>					
Permitted ambient temperature	°C	10... 35			
Sound level <sup>4)</sup>	dB(A)	47	50	52	48
Dimensions (height x depth x width)	mm	600 x 645 x 1800			
Weight (without packaging)	kg	200	202	210	218

Table 10 Technical data

1) With internal pump acc to EN 14511

2) Glycol

3) Global Warming Potential, GWP<sub>100</sub> = 1526

4) Acc to EN 3743-1

7.3.2 Diagram circulation pumps C6-C11

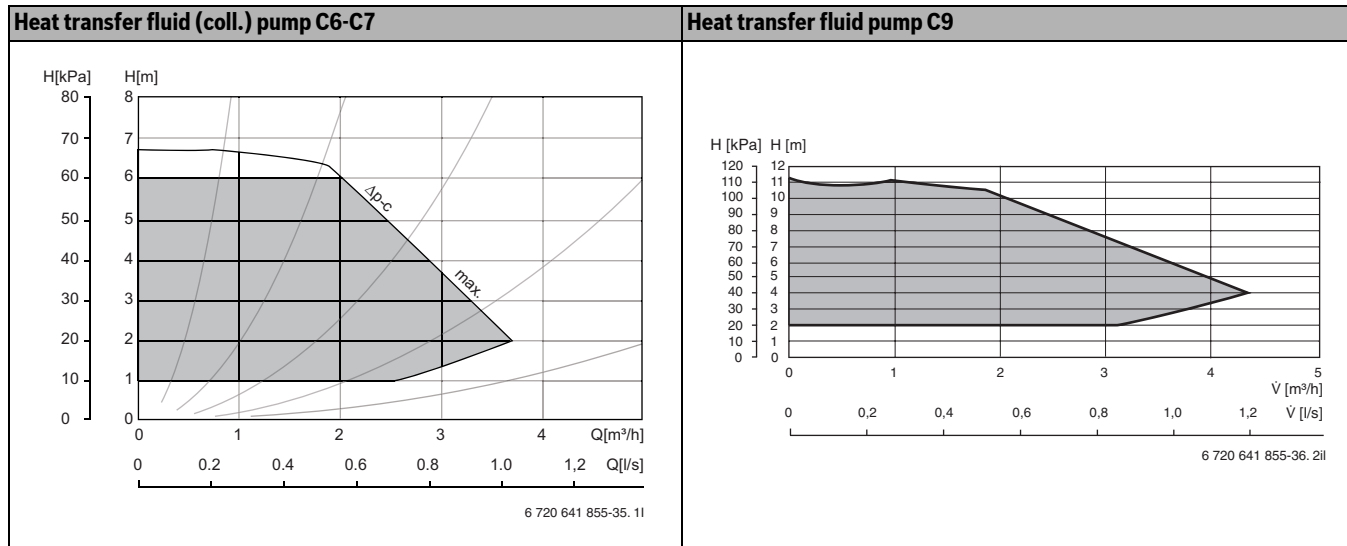

Table 11

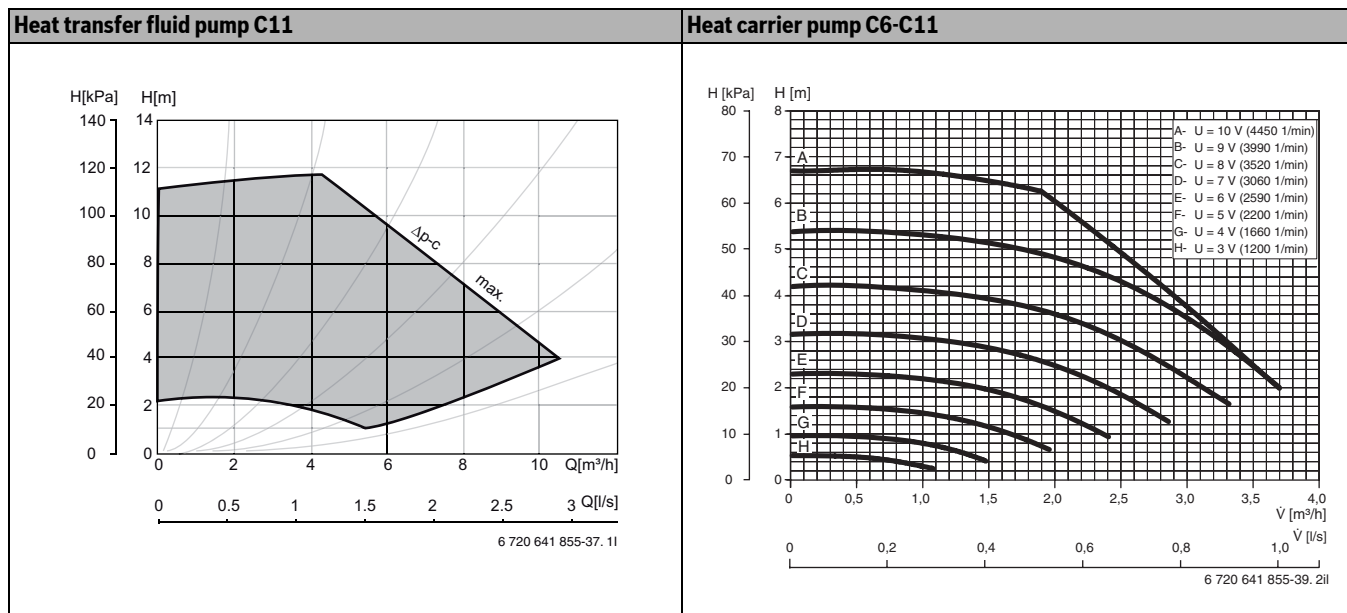

Table 12

[H] Residual lift height  
 [Q] Flow

## 7.3.3 E6 - E11

	Unit	E6	E7	E9	E11
<b>Mode fluid/water</b>					
Heat output (B0/W35) <sup>1)</sup>	kW	5,0	6,6	8,7	10,2
Heating output (B0/W45) <sup>1)</sup>	kW	4,8	6,2	8,3	9,6
COP (B0/W35) <sup>1)</sup>	-	3,51	3,82	3,84	3,97
COP (B0/W45) <sup>1)</sup>	-	2,82	2,97	3,15	3,17
<b>Heat transfer fluid</b>					
Nominal flow (delta_T = 3K <sup>2)</sup> )	l/s	0,20	0,41	0,50	0,62
Permitted external pressure drop <sup>2)</sup>	kPa	47	43	80	91
Max. pressure	bar	4			
Contents (internal)	l	5			
Operating temperature	°C	-5... +20			
Connection (Cu)	mm	28			
<b>Compressor</b>					
Type		Mitsubishi scroll			
Weight cooling agent R407c <sup>3)</sup>	kg	1,6	1,6	1,8	2,4
Max. pressure	bar	31			
<b>Heating system</b>					
Nominal flow (delta_T = 7K)	l/s	0,20	0,25	0,31	0,38
Min. flow temperature	°C	20			
Max. flow temperature	°C	65			
Max. permitted operating pressure	bar	3			
Hot water content	l	7			
Connection (Cu)	mm	22			
<b>Values for electrical connection</b>					
Electrical supply		230V 1N~50Hz			
Fuse, slow; with electric additional heat 3/6/9 kW	A	25/40/63	32/40/63	32/50/63	40/50/63
Nominal power consumption compressor (B0/W35)	kW	1,17	1,48	1,78	2,09
Max. current with soft starter	A	<35			
Enclosure class	IP	X1			
<b>General</b>					
Permitted ambient temperature	°C	10...35			
Sound level <sup>4)</sup>	dBA	47	50	52	48
Dimensions (height x depth x width)	mm	600 x 645 x 1520			
Weight (without packaging)	kg	150	155	165	175

Table 13 Technical information

1) With internal pump acc to EN 14511

2) Glycol

 3) Global Warming Potential, GWP<sub>100</sub> = 1526

4) Acc to EN 3743-1

7.3.4 Diagram circulation pumps E6-E11

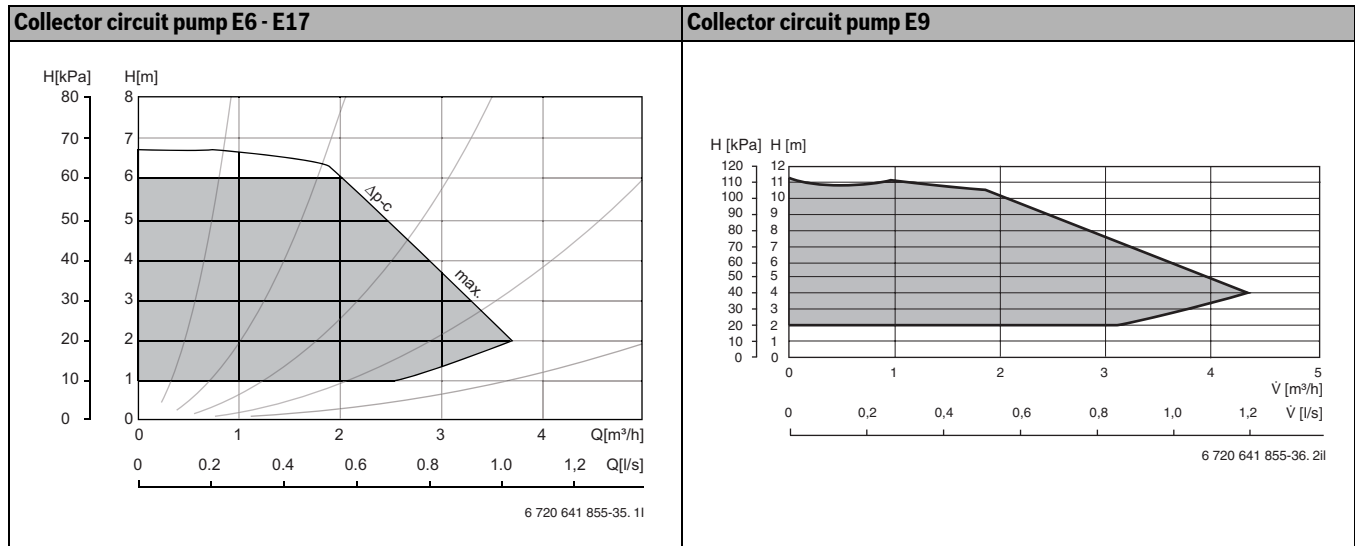

Table 14

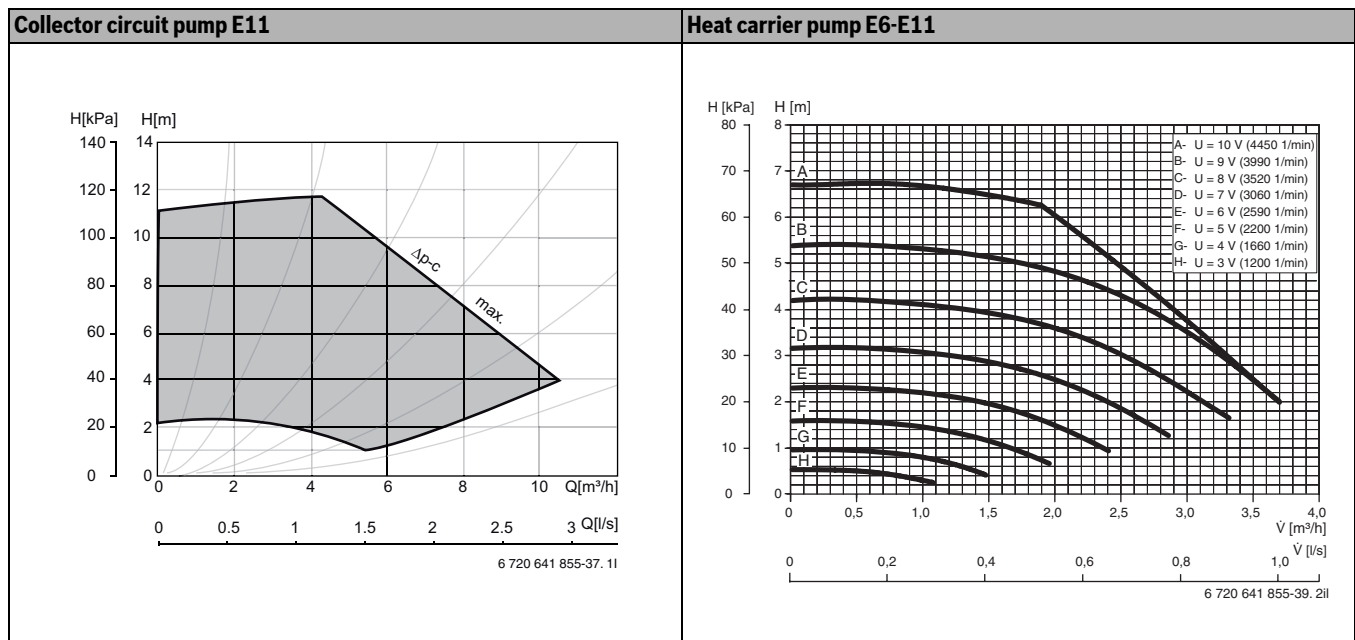

Table 15

[H] Residual lift height  
 [Q] Flow

7.3.5 Measurement values for temperature sensor

°C	$\Omega_{T...}$	°C	$\Omega_{T...}$	°C	$\Omega_{T...}$	°C	$\Omega_{T...}$
-40	154300	-5	19770	30	3790	65	980
-35	111700	0	15280	35	3070	70	824
-30	81700	5	11900	40	2510	75	696
-25	60400	10	9330	45	2055	80	590
-20	45100	15	7370	50	1696	85	503
-15	33950	20	5870	55	1405	90	430
-10	25800	25	4700	60	1170		

Table 16 Measurement values for temperature sensors



## 8 Regulations

The following regulations and requirements must be observed:

- The responsible power supply company's local regulations and requirements, including any corresponding special rules
- National building regulations
- **EN 60335** (Electrical appliances and similar utilities - Safety)
  - part 1** (General demands)
  - part 2-40** (Special demands on electrical heat pumps, air conditioners and air dehumidifiers)
- **EN 12828** (Heating systems in buildings - Design and installation of water-based heating systems)

## 9 Installation



Only qualified installers may carry out the installation. The installer must follow applicable rules and regulations and recommendations from the supplier.

### 9.1 Collector system

#### Installation and filling

Installation and filling of the collector system should comply with applicable laws and regulations. Soil used for refilling around the collector hose must not contain stones or other sharp objects. Pressure test the collector system before refilling to ensure that the system is watertight.

When cutting the collector, it is important that no dirt or gravel enters the system. This can cause blockages in the heat pump and damage components.

#### Filling unit

A filling unit is included in the delivery and should be installed close to the collector circuit inlet.

#### Expansion vessel, safety valve, pressure gauge

The expansion vessel, safety valve and pressure gauge are to be provided by the dealer.

#### Collector circuit pump

Factory setting for the collector circuit pump is max (→ Figure 16). The setting may need to be adjusted to achieve the correct delta value (→ Chapter 13.4 ). The value must lie within the grey area. To adjust the value, turn the dial.

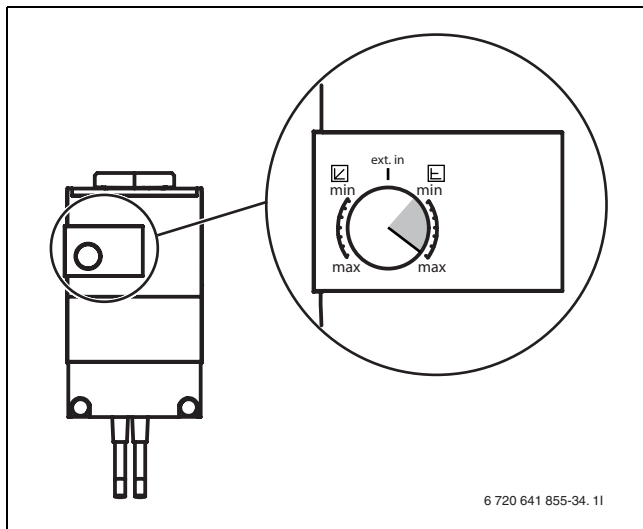

Fig. 16

### Expansion vessel

It is important when installing the expansion vessel to position it at the highest point in the circuit, preferably above the heat pump. If there is a low ceiling making it impossible to fit the tank above the pump, it can be positioned as illustrated in the figure to the left. It is important to install the tank so that any air disappears upwards. If the tank is installed incorrectly, the air will continue on in the circuit (→Figure 17).

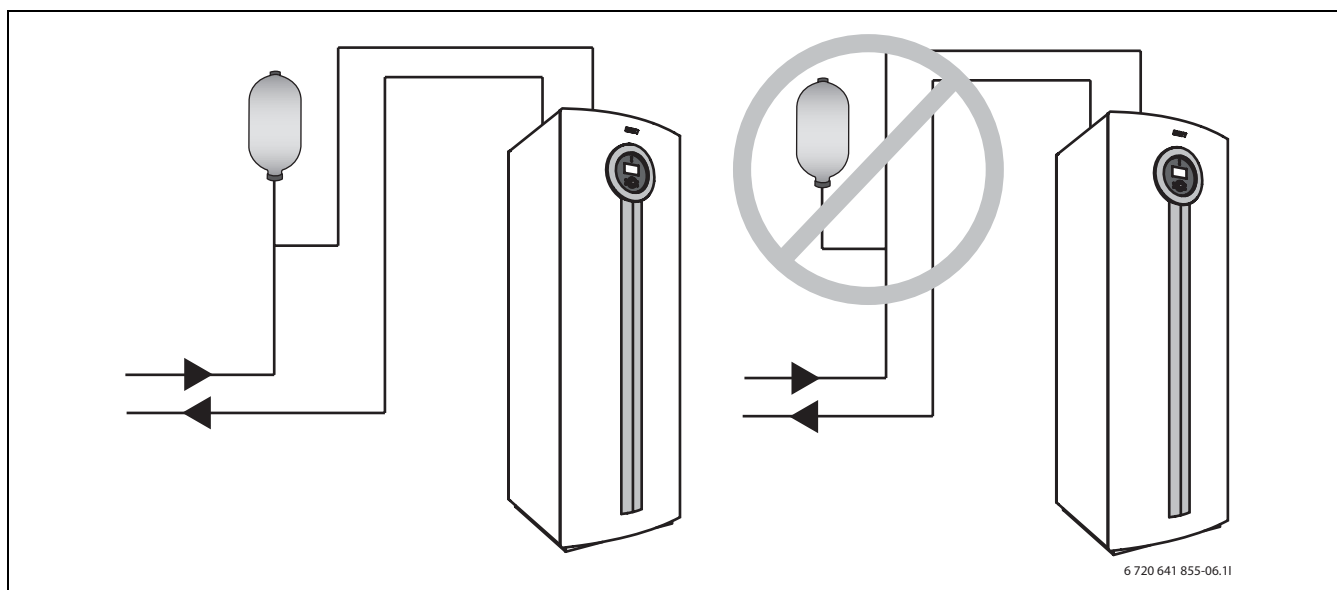

Fig. 17 Installing the expansion vessel

As an alternative to a plastic vessel a membrane expansion vessel in the heat transfer circuit can be used.

Select membrane expansion vessel according to:

Model	Volume
C6-C11, E6-E11	12 litres

Table 17

### Antifreeze/Corrosion preventative

Frost protection to -15 °C should be ensured. We recommend the primary use of bio-ethanol, otherwise propylene glycol.

## 9.2 Heating system

### Particle filter (integrated in E6 - 11)

A particle filter for the heating system is included in the delivery of C6-C11 and should be installed on the connection for the heating system's return line.

### Heat carrier pump

Factory setting for the heat carrier pump is ext. in (→ Figure 18). The factory setting (ext. in) on the heat carrier pump must not be changed using the dial, the pump settings are controlled from the control unit.

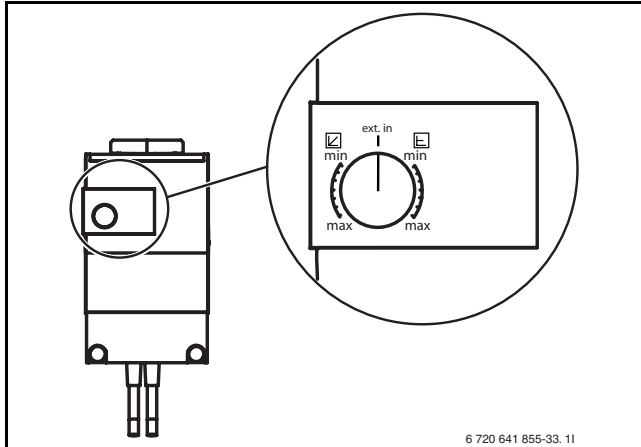

Fig. 18

### Propylene glycol

Glycol is not normally used in the heating system. In special cases, where increased protection is required, glycol can be added with a maximum concentration of 15%. Heat pump performance will however decrease.

	<p><b>WARNING:</b></p> <ul style="list-style-type: none"> <li>▶ No other anti-freeze may be used in the heating system.</li> </ul>
--	--

### Safety valve

Pursuant to EN 12828, a safety valve should be used. The safety valve should be installed vertically.

	<p><b>WARNING:</b></p> <ul style="list-style-type: none"> <li>▶ Never block the safety valve outlet.</li> </ul>
--	---

## 9.3 Siting the appliance

Noise transfer to adjacent areas must be taken into consideration when choosing a position for the heat pump (→ Chapter 7.3 for sound levels).

## 9.4 Pipework preparations

- ▶ Connection pipes for the collector system, heating system and possible hot water should be installed in the premises to the heat pump location.
- ▶ An expansion vessel, a safety group and a pressure gauge should be mounted in the heating circuit (accessories).
- ▶ Mount the filling unit in a suitable place in the collector circuit.

## 9.5 Flushing out the heating system

The heat pump is a part in a heating system. Faults in the heat pump can be caused by poor water quality in the radiators/floor loops or air penetrating the system continuously.

Oxygen causes corrosion products in the form of magnetite and sediment.

Magnetite has a grinding effect on the heating system's pumps, valves and components with turbulent flows such as the condenser.

Heating systems which require regular filling or where the heating water is not clear when drained, require remedial measures before the installation of a heat pump, for example the heating system must be fitted with filters and vents.

Do not use any water treatment additives except agents for raising the pH level. Recommended pH value is 7.5 – 9.

An intermediate heat exchanger is sometimes necessary to protect the heat pump.

	<p><b>CAUTION:</b> The heat pump may become damaged in the event of dirt or other particles in the pipework.</p> <ul style="list-style-type: none"> <li>▶ Flush out the system to remove all dirt residues.</li> </ul>
--	--

## 9.6 Setting up

- ▶ Remove packing, taking care to observe the instructions on the packing.
- ▶ Remove the supplied accessories.
- ▶ Install the supplied adjustable feet and adjust the height.

## 9.7 Heat insulation

All heat transfer and collector circuits must have suitable heat and condensation insulation according to applicable norms.

## 9.8 Removing the front panel

- ▶ Loosen the screws, tilt the front panel outwards and take it off.

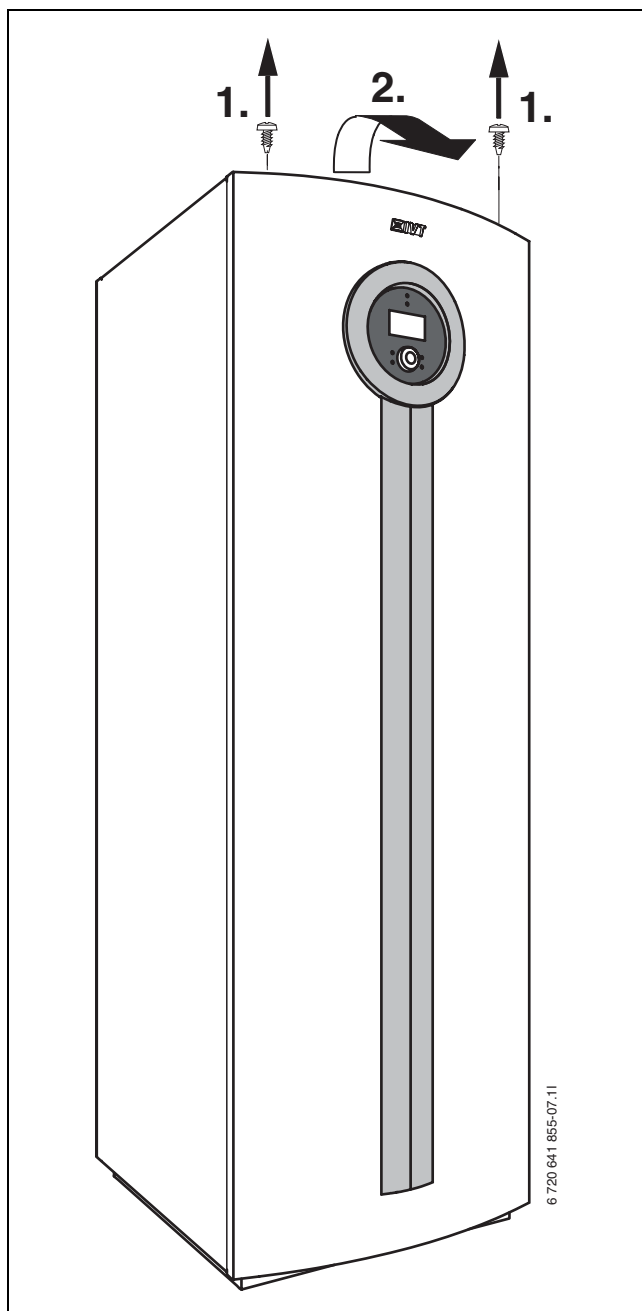

Fig. 19

## 9.9 Temperature sensor installation

### 9.9.1 Flow sensor T1

- ▶ Install the sensor in direct contact with the flow line pipe and preferably after a 90° bend (horizontally), according to the system diagram.
- ▶ With buffer tank: Install the sensor in the upper part of the buffer tank, according to the system solution. See installation instructions for the buffer tank.

### 9.9.2 Outdoor sensor T2

- ▶ Install the sensor on the coldest side of the house. It must be protected from direct sunlight, ventilation air or anything that can affect the temperature measurement. The sensor must not be installed directly beneath the roof.

### 9.9.3 Hot water sensor T3

**C:** The sensor is pre-installed in the hot water heater.

**E:** The sensor must be installed when the external hot water heater is used. Install the sensor approx 1/3 up from the bottom of the hot water heater. The sensor must be installed over the return connection to the heat pump.

### 9.9.4 Room sensor T5 CANbus LCD (accessory)

See separate instruction manual for complete information.



When installing the room sensor the control unit must be set to Installer level.



One CANbus LCD room sensor can be connected per circuit.



It is only the room where the room sensor is located that can influence regulation of the temperature for the relevant heating circuit.

Installation location requirements:

- If possible, interior wall without drafts or heat radiation.
- Unimpeded circulation of room air under room sensor T5 (dotted area in figure 20 must be kept clear).

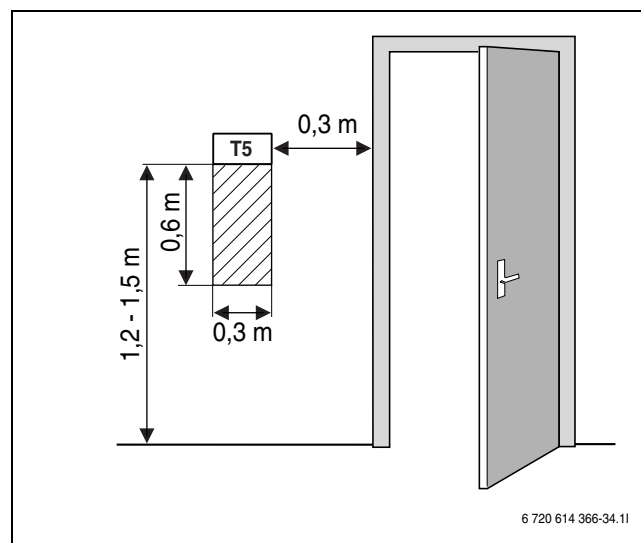



Fig. 20 Recommended installation location for room sensor T5

### 9.10 Filling the heating system

- ▶ Set the pre-pressure for the expansion vessel in the premises according to the heating unit's statistical height.
- ▶ Open the heating system's valves.
- ▶ Open the stopcock on the particle filter, fill the heating system to between 1 and 2 bar and close it.
- ▶ Vent the heating system.
- ▶ Refill the heating installation to between 1 and 2 bar.
- ▶ Check all connections for leaks.



**WARNING:** The water heater can crack if filling is performed in the wrong order.

- ▶ Fill and pressurise the water heater **before** filling the heating system.

### 9.11 Filling the collector system

The collector system is filled with collector circuit fluid which must guarantee antifreeze protection until  $-15\text{ }^{\circ}\text{C}$ . We recommend bio-ethanol or a mixture of water and propylene glycol.



Only glycol and alcohol are permitted.

A rough estimate of the amount of collector circuit fluid that is required in relation to the length of the collector system and the inner diameter of the pipe can be made using table 18.

Inner diameter	Volume per metre	
	Single pipes	Double U pipes
28 mm	0.62 l	2.48 l

Table 18



Single U pipes, consisting of one descending and one ascending pipe, are most often used as a rock collector.

The following description of filling presupposes the use of the filling station accessory. Follow corresponding steps if other equipment is used.

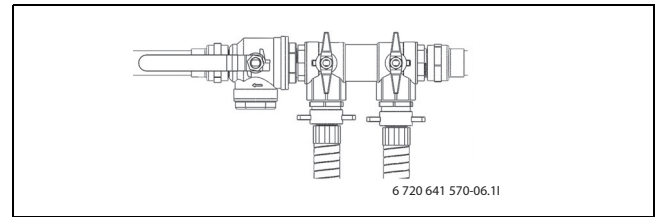

Fig. 21 Filling unit

- ▶ Connect two hoses from the filling station to the filling unit (→ Figure 22).

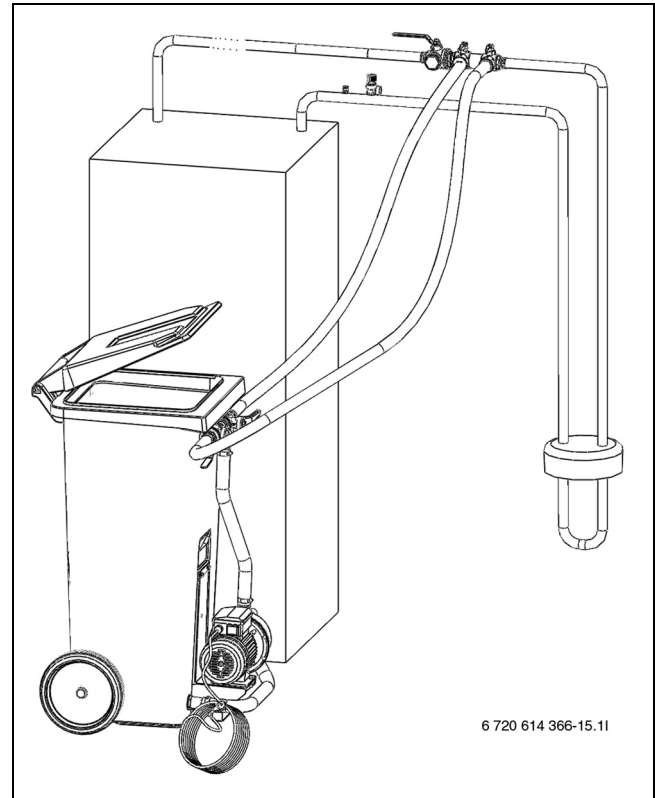

Fig. 22 Filling with filling station

- ▶ Fill the filling station with collector circuit fluid. Fill water before you fill antifreeze.
- ▶ Turn the valves on the filling unit so that they are in filling position (→ Figure 23).

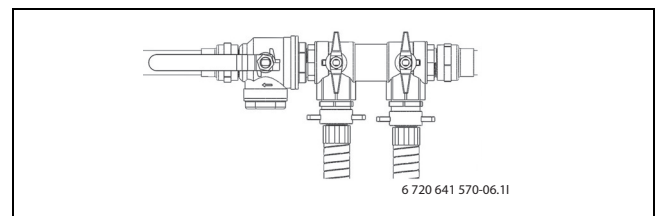

Fig. 23 Filling unit in filling position

- ▶ Turn the valves on the filling station so that they are in mixing position (→ Figure 24).

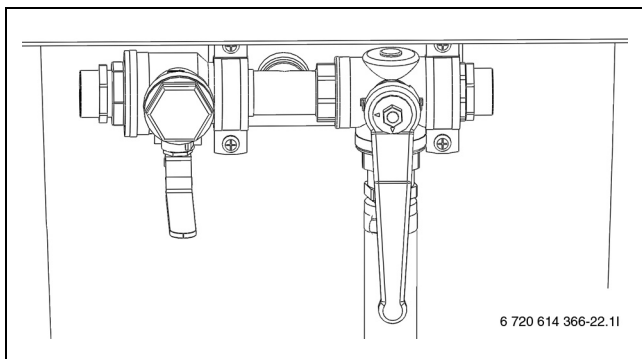

Fig. 24 Filling station in mixing position

- ▶ Start the filling station (pump) and mix the collector circuit fluid for at least two minutes.



Repeat the following steps for each circuit. One circuit at a time is filled with collector circuit fluid. Keep the valves closed in the other loops during the process.

- ▶ Turn the valves on the filling station to filling position and fill the circuit with collector circuit fluid (→ Figure 25).

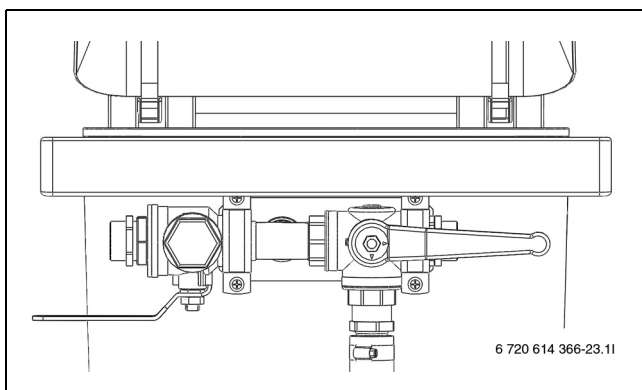

Fig. 25 Filling unit in filling position

- ▶ When the fluid level has fallen to 25% in the filling station, the pump should be stopped and more collector circuit fluid should be filled and mixed.
- ▶ When the circuit is full and air no longer comes from the return pipe, the pump should be run again for at least 60 minutes (the fluid should be clear and should not contain any bubbles).

- ▶ The circuit must be pressurized when venting is complete. Turn the valves on the filling unit to pressure increase position and pressurize the circuit to 2.5 to 3 bar (→ Figure 26).

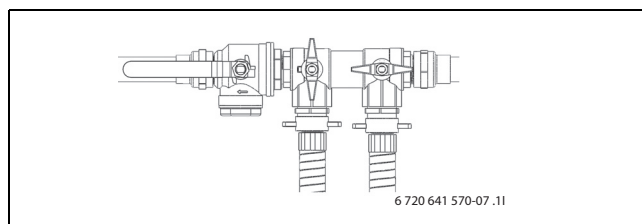

Fig. 26 Filling unit in pressure increase position

- ▶ Turn the valves of the filling unit to normal position (→ Figure 27) and turn off the pump on the filling station.

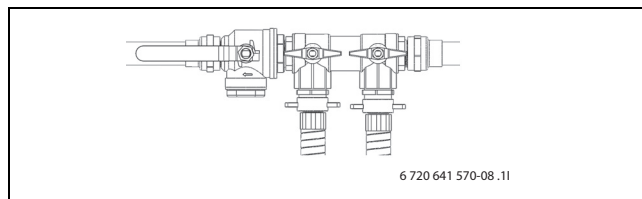

Fig. 27 Filling unit in normal position

- ▶ Disconnect the hoses and insulate the filling unit.

If other equipment is used, the following is required, among other things:

- A clean container with capacity for the amount of collector circuit fluid that is required
- An additional container for collection of contaminated collector circuit fluid
- Submerged pump with filter, flow capacity of min. 6 m<sup>3</sup>/h, pressure height of 60 to 80 m
- Two hoses, Ø 25 mm

## 10 Electrical connections



**DANGER:** Risk of electric shock!

- ▶ Switch off the main power supply before starting work on the electrical part.

All regulation, control and safety devices on the heat pump are connected and checked upon delivery.



The heat pump's electrical connections must be able to be disabled safely.

- ▶ Install separate safety switch that cuts all current to the heat pump. A safety switch for each supply is required for separate power supplies.
- ▶ Install a separate earth breaker for the heat pump.

- ▶ According to applicable regulations for connecting supply voltage. Select cable area and cable type that corresponds to the relevant fuse rating (→ Chapter 7.3 ) and routing method.
- ▶ Connect the heat pump to the electric box connection strip according to BS EN 60335 part 1 and via a switch with a minimum contact distance of 3 mm (e.g. fuses, LS switch). Other consumers must not be connected.
- ▶ Follow the relevant wiring diagram when connecting an earth breaker. Only connect components that are approved for each market.
- ▶ Observe the colour coding when replacing circuit boards.

### 10.1 Connecting the heat pump



**CAUTION:** Never grasp a circuit board without wearing a ground-connected bracelet (→ Chapter 3.10 ).

- ▶ Remove the front panel (→ page 29).
- ▶ Remove the electric box cover.
- ▶ Route the connection cables to the electric box through the cable gland in the roof plate of the heat pump.
- ▶ Connect the cables according to the wiring diagram.
- ▶ Reinstall the electric box cover and the front panel of the heat pump.

### 10.2 Soft starter

The soft starter has four different alarm causes, see table below. Type 2 alarms are due to large voltage variations in the electricity grid. Type 3 alarms indicate the existence of a fault in the compressor. Types 4 and 5 alarms are there to protect the soft starter.



The soft starter has normally 1 minute restart delay. The restart delay is 5 minutes at an alarm.

Number of flashes red LED	Conditions	Action
2	Undervoltage ( $U_e < 190VAC^{1)}$ )	Auto reset with 5 min. recovery <sup>2)</sup>
3	Overcurrent during start-up ( $> 80A$ for 1 s.)	Auto reset with 5 min. recovery
4	Relay protection	User action/possible replacement of unit
5	Incomplete ramp	Auto reset with 5 min. recovery

Table 19

1)  $< 190 VAC_{rms} \pm 2\%$  at  $\geq 1$  s.

2) Contact network supplier if alarm remains.



If same alarm is repeated even after manual restart, the unit should be replaced (refers to 4 and 5 flashing alarms).



### 10.3 Electrical connection wiring diagram

#### 10.3.1 Overview of circuit boards

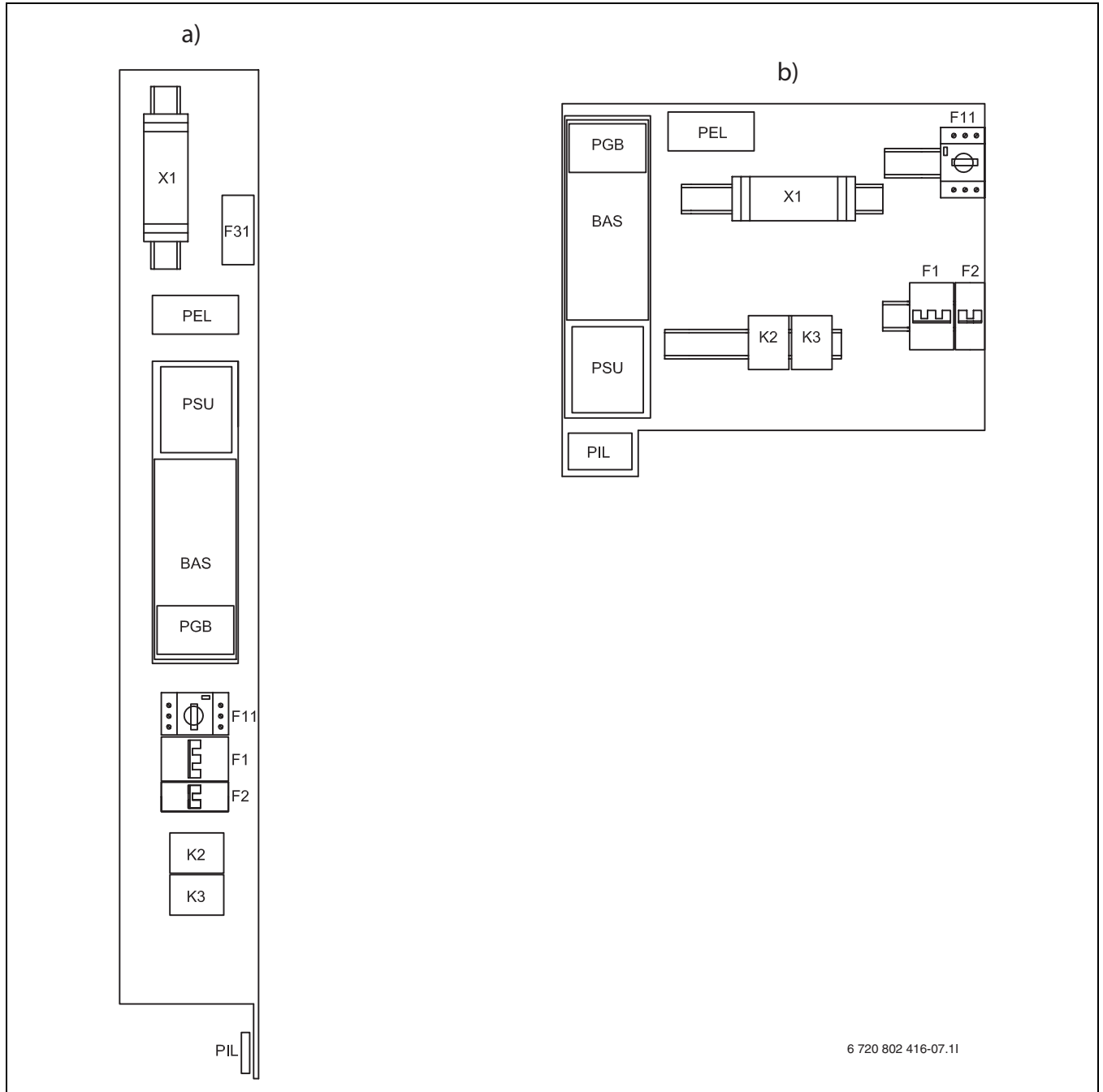

Fig. 28 Overview PCB

- [F1] Miniature circuit breaker electric additional heat
- [F2] Miniature circuit-breaker heat pump
- [F11] Motor cut-out compressor
- [K2] Contactor electric additional heat stage 1
- [K3] Contactor electric additional heat stage 2
- [X1] Terminal block
- [BAS] Circuit board
- [PGB] Circuit board
- [PIL] Circuit board
- [PEL] Circuit board
- [PSU] Circuit board
- [F31] PCB protective anode (only stainless water heater)
- [a)] 6-11 kW C-model
- [b)] 6-11 kW E-model

10.3.2 CANbus overview

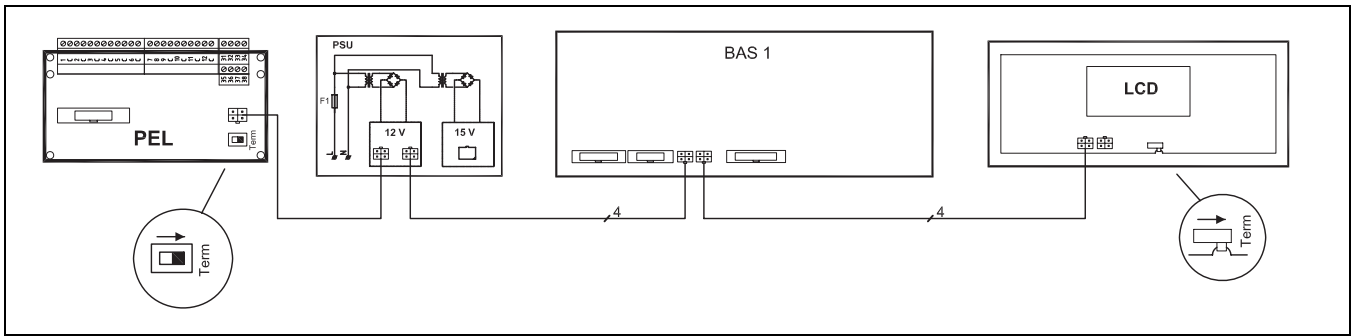
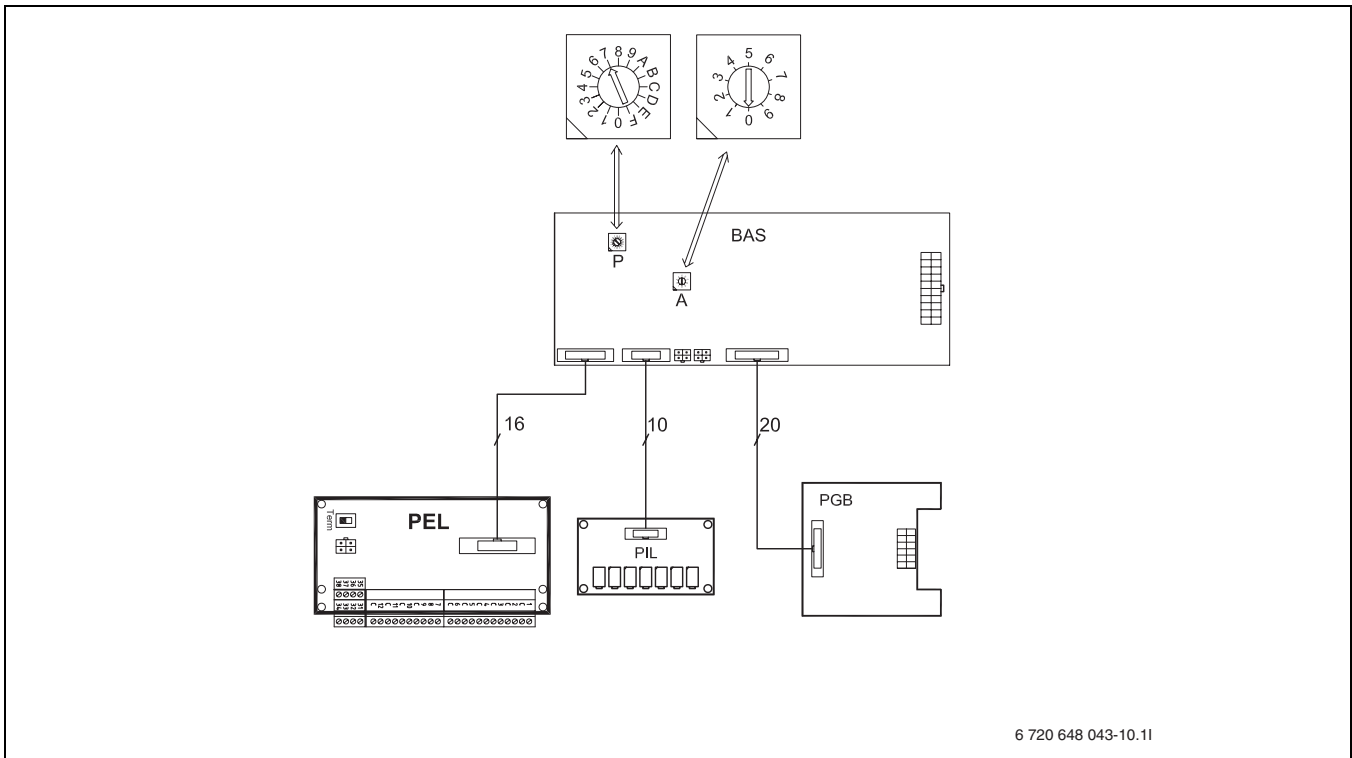

Fig. 29 CANbus overview

10.3.3 Circuit board wiring



6 720 648 043-10.11

Fig. 30 Circuit board wiring

10.3.4 Power supply

The terminal blocks are strapped at the factory to a common power supply. Connect to L1, 1N and PE.

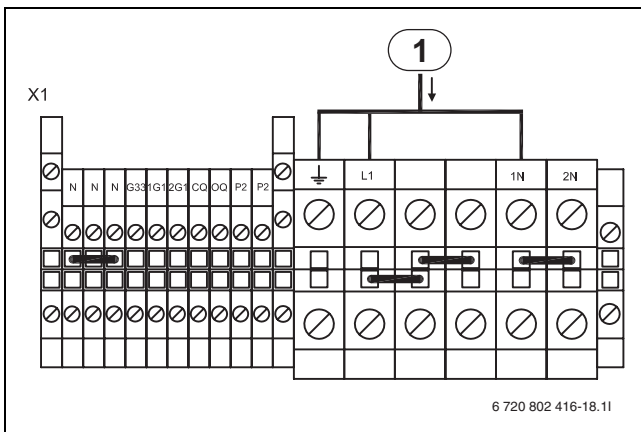

6 720 802 416-18.11

Fig. 31 Power supply

[1] Supply, heat pump

## 10.3.5 Internal wiring diagram

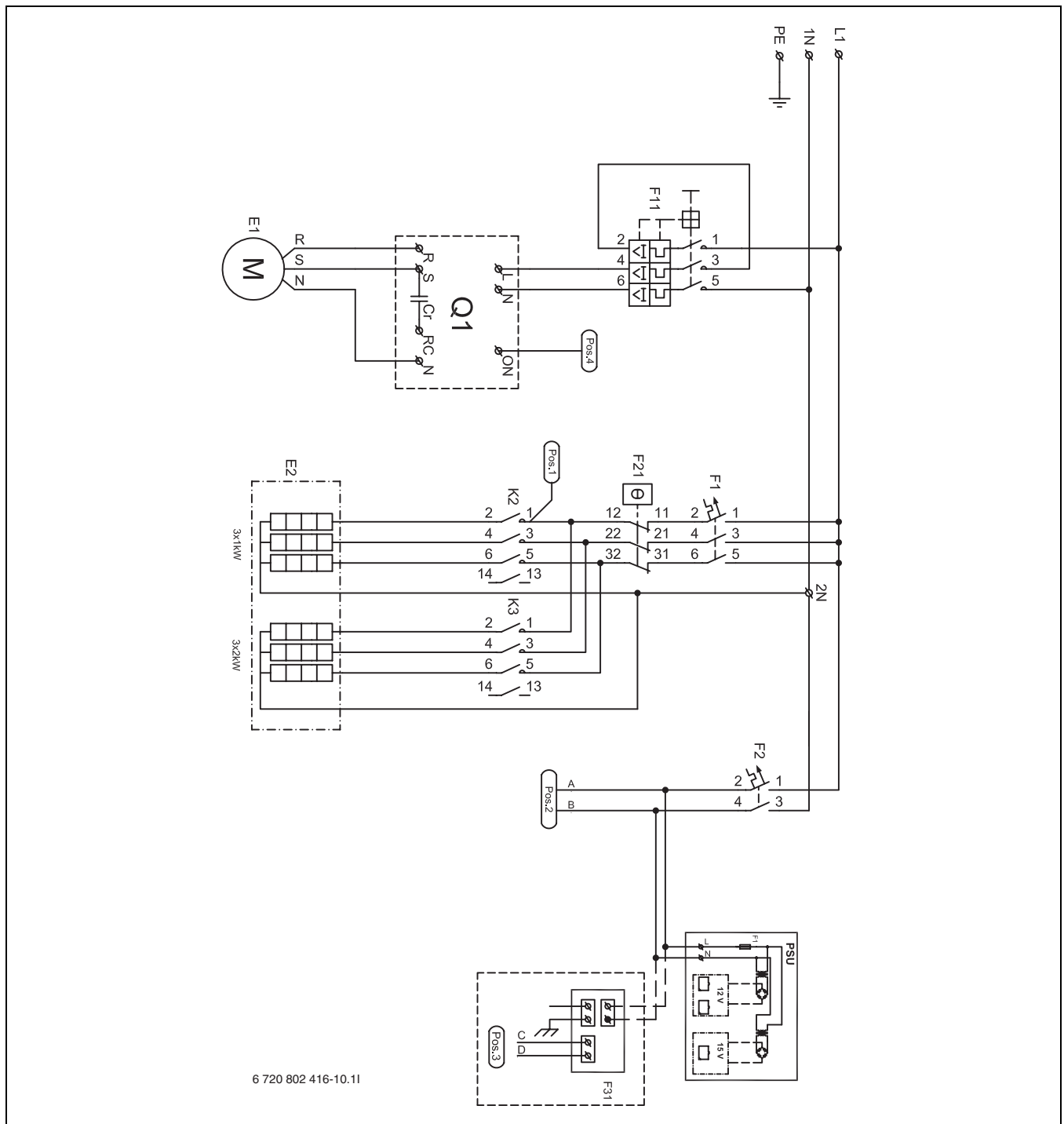
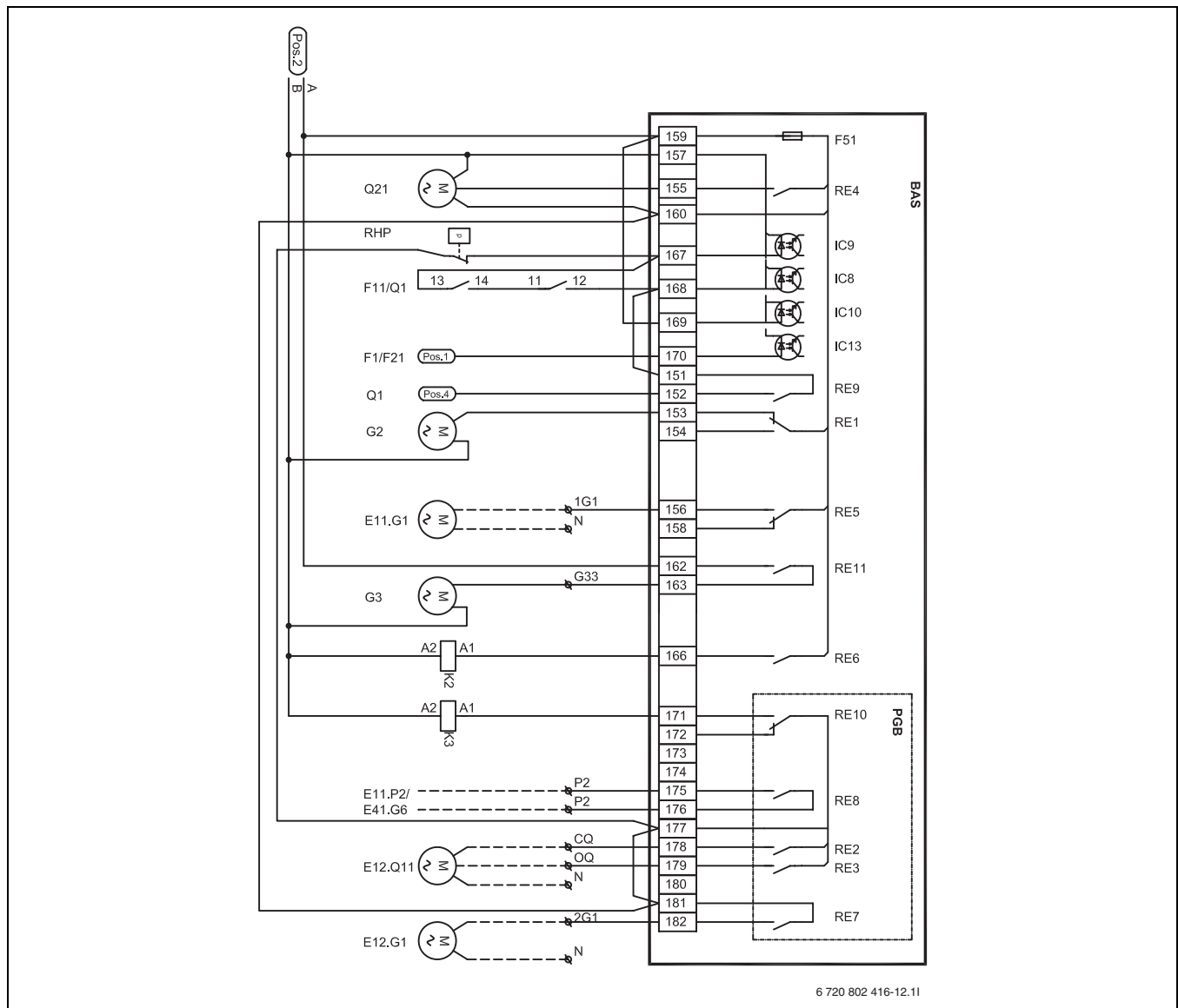

Fig. 32 Internal wiring diagram

- [E1] Compressor
- [E2] Electric additional heat
- [F1] Miniature circuit breaker electric additional heat
- [F2] Miniature circuit-breaker heat pump
- [F11] Motor cut-out compressor
- [F21] Power supply to overheat protection
- [F31] Protective anode, C-model with stainless water heater
- [K2] Contactor electric additional heat stage 1
- [K3] Contactor electric additional heat stage 2
- [Q1] Soft starter
- [PSU] Circuit board

10.3.6 Complete wiring diagram connections



6 720 802 416-12.11

Fig. 33 Complete wiring diagram connections (230V)

**Solid line = factory set connection**

**Dotted line = connect during installation:**

- [RHP] High pressure switch
- [F11] Motor cut-out compressor
- [F1/F21] Fuse/overheat protection electric additional heat
- [Q1] Soft starter
- [K2] Contactor electric additional heat stage 1
- [K3] Contactor electric additional heat stage 2
- [E11.G1] Circulation pump circuit 1
- [G2] Heat carrier pump
- [G3] Collector circuit pump
- [Q21] 3-way valve
- [F51] Fuse 6.3A
- [E11.P2<sup>1)</sup>] General alarm
- [E41.G6<sup>1)</sup>] Circulation pump hot water
- [E12.Q11] Extra mixing valve circuit 2
- [E12.G1] Circulation pump circuit 2



E12.G1: When a low energy pump is connected, an external control relay must be used. The pump is connect to the power grid with a dedicated supply.

1) P2- P2 potential free connection for cirkulation pump / general alarm

10.3.7 Complete wiring diagram connections

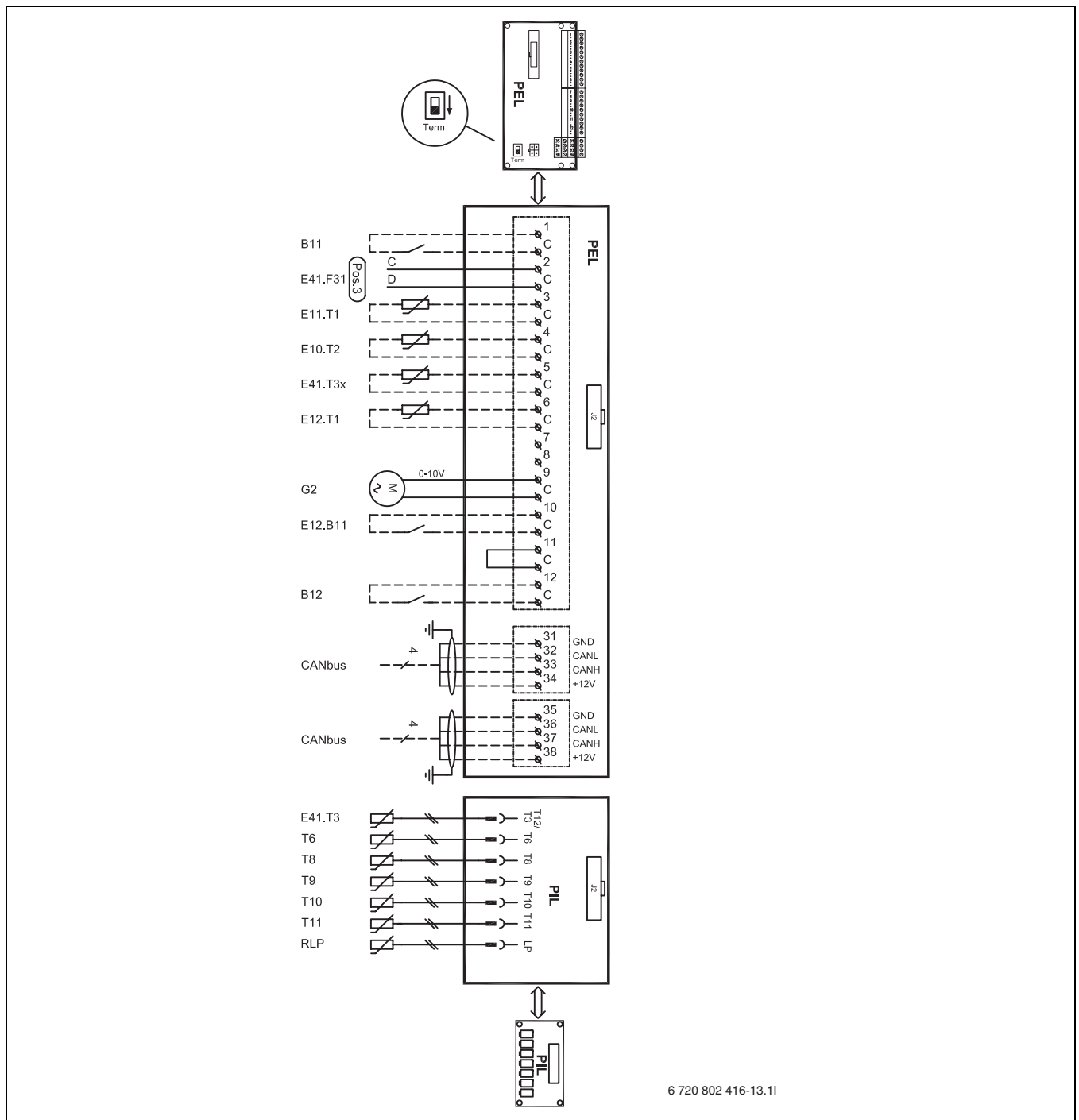

Fig. 34 Complete wiring diagram connections (low current)

**Solid line = factory set connection**

**Dotted line = connect during installation:**

- |           |                           |          |                         |
|-----------|---------------------------|----------|-------------------------|
| [B11]     | External input 1          | [B12]    | External input 2        |
| [E41.F31] | Alarm protective anode    | [E41.T3] | Hot water C-model       |
| [E11.T1]  | Flow                      | [T6]     | Hot gas sensor          |
| [E10.T2]  | Outdoor sensor            | [T8]     | Heat transfer fluid out |
| [E41.T3x] | Hot water E model         | [T9]     | Heat transfer fluid in  |
| [E12.T1]  | Flow circuit 2            | [T10]    | Collector circuit in    |
| [G2]      | Heat carrier pump         | [T11]    | Collector circuit out   |
| [E12.B11] | External input, circuit 2 | [RLP]    | Low pressure switch     |

### 10.4 External connections

All external connections are made on terminal board PEL (low current) and connection terminal blocks.

► High and low current cables should be routed separately in order to avoid interference on the sensors (minimum distance of 100 mm).

► Use the following cable area when extending the temperature sensor cable:

- Up to 20 m long cable: 0.75 till 1.50 mm<sup>2</sup>
- Up to 30 m long cable: 1.0 till 1.50 mm<sup>2</sup>

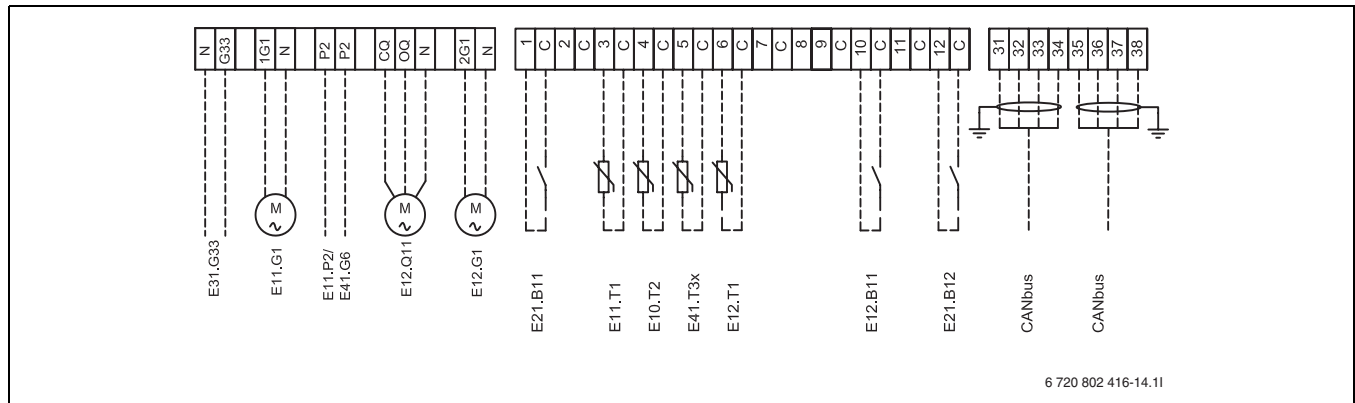

Fig. 35 External connections

**Solid line = always connected**

**Dotted line = option, alternative:**

- [E31.G33] Control signal circulation pump ground water
- [E11.G1] Circulation pump circuit 1
- [E11.P2] General alarm
- [E41.G6] Circulation pump hot water
- [E12.Q11] Extra mixing valve circuit 2
- [E12.G1] Circulation pump circuit 2
- [B11] External input 1
- [E11.T1] Flow circuit 1
- [E10.T2] Outdoor sensor
- [E41.T3x] Hot water
- [E12.T1] Flow circuit 2
- [E12.B11] External input, circuit 2
- [B12] External input 2

### 10.5 Connection groundwater pump

Connect groundwater pump to the power supply with dedicated input (230). The control to the contactor uses 230V which is taken from terminals G33 and N in the heat pump.

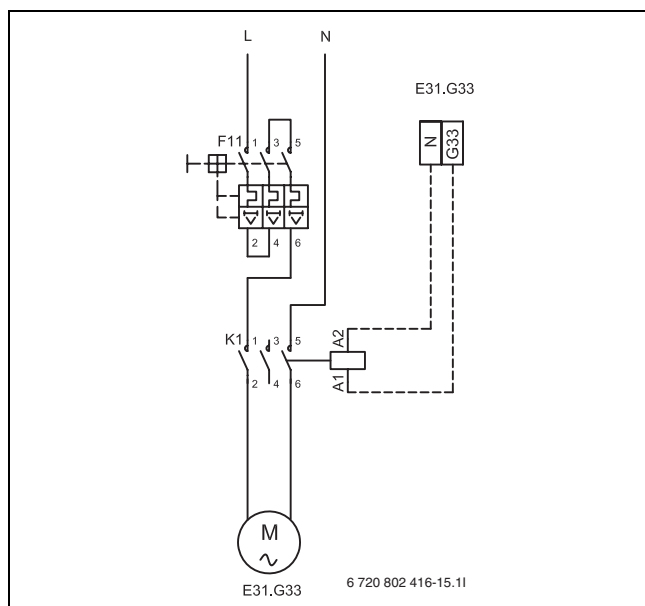
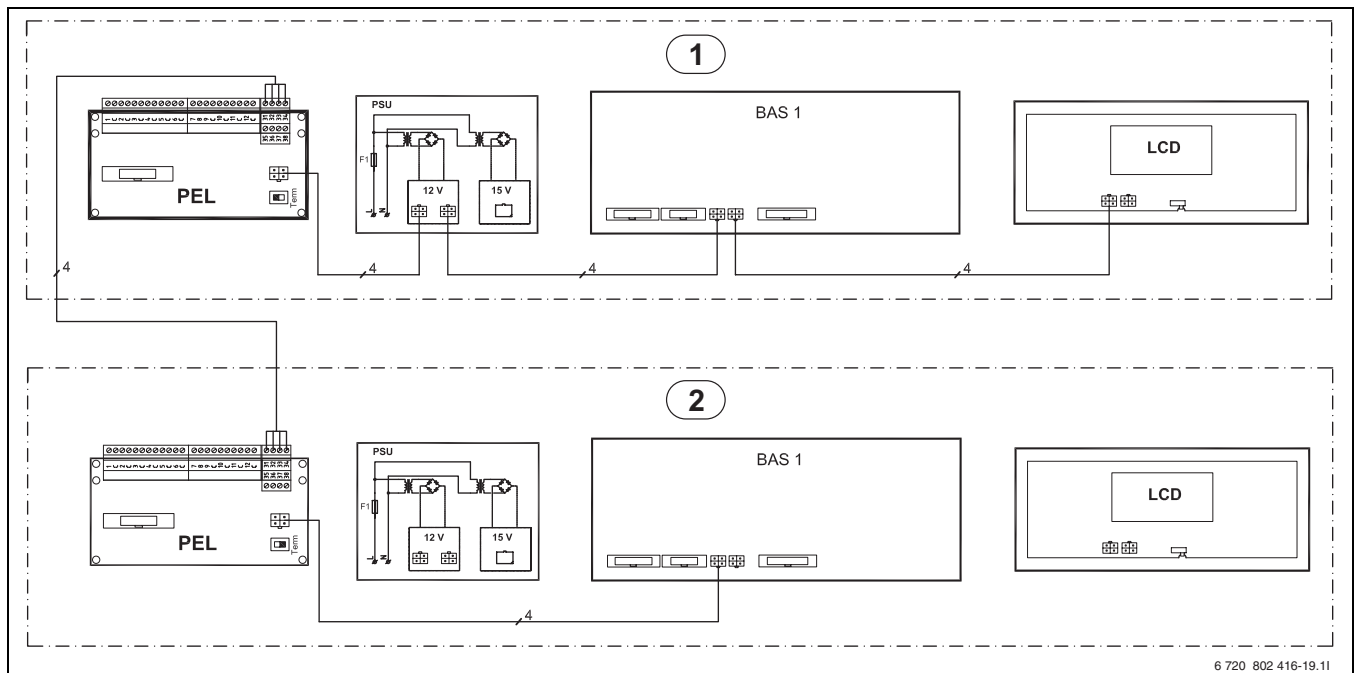

Fig. 36 Connection groundwater pump

## 10.6 Combined operation of two heat pumps (cascade connection)



6 720 802 416-19.11

Fig. 37 CANbus overview with two heat pumps

**CAUTION:** Do not mix up the 12V and CAN-BUS connections!  
The processors are destroyed if 12V is connected to the CAN-BUS.

- ▶ Check that the four cables are connected to the contacts with the corresponding marking on the circuit board.

**i** In cascade connection both heat pumps must have the same output.

**i** PSU and LCD (→ Figure 37) in heat pump 2 are factory connected, these must be disconnected and are not used in cascade connection.

**i** The recommended cabling is ELAQBY 2x2x0.5. If other cables are used besides the recommended ones, the following must be complied with: screened, twisted pair, max 30 m, min area 0.5.

1. Pull the new cabling (according to specified cable) between screw terminal 31-34 on the PEL board (heat pump 1) and screw terminal 31-34 on the PEL board (heat pump 2).
2. Remove the display cabling in heat pump 2 between BAS and LCD. Remove the bottom strap to release the cable.
3. Pull out the earth wire from the removed display cabling and re-connect this to the earth terminal and the earth plate in the front plate of the heat pump 2.
4. Re-connect CANbus with existing CANbus cabling in heat pump 2 (→ Figure 37).
5. Use cable ties to again fasten cabling in a suitable manner.

6. Re-address BAS (heat pump 2) from A=0 to A=1 (→ Figure 38). Set termination switch to Term mode on PEL (heat pump 2).

If one wishes to proceed to accessories, this is done from either heat pump 1 or heat pump 2 - PEL CAN 2 and then set the termination switch to non-Term mode.

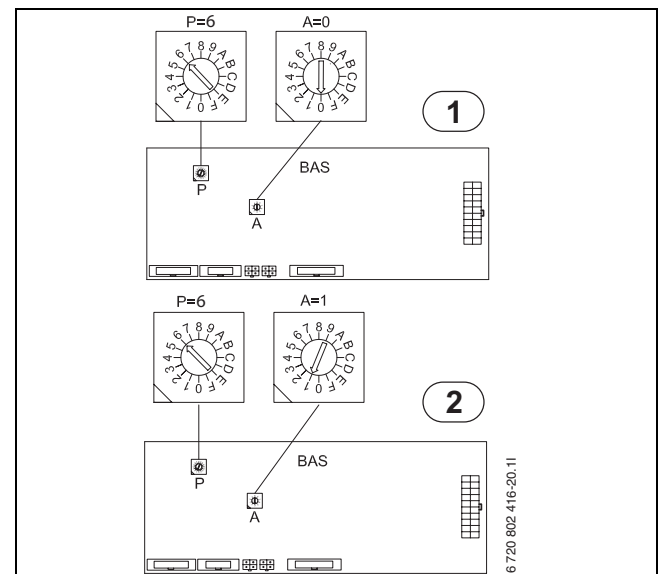

6 720 802 416-20.11

Fig. 38 Addressing heat pumps 1 and 2.

## 11 Control panel

Settings for the control of the heat pump are made with the control unit's control panel, which also provides information about current status.

### 11.1 Panel overview

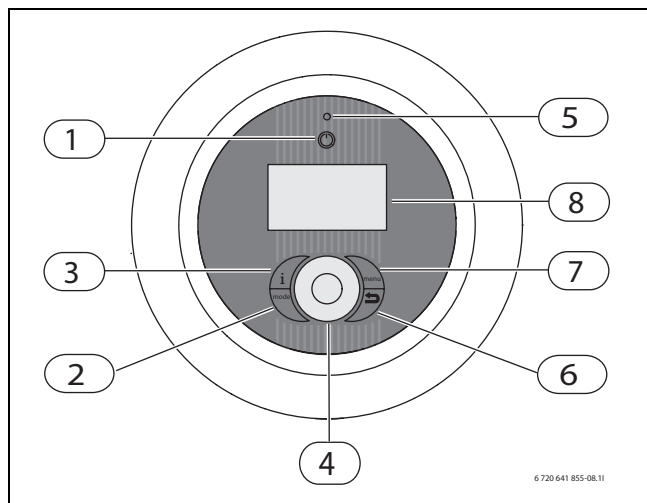

Fig. 39 The control panel

- [1] On/Off button
- [2] Mode button
- [3] Info button
- [4] Menu dial
- [5] Status lamp
- [6] Return button
- [7] Menu button
- [8] Menu display

### 11.2 On/Off button

Use the On/Off button to switch the heat pump on and off.

### 11.3 Status lamp

The lamp lights green.	The heat pump is running.
The lamp flashes red.	There is an alarm which has not been acknowledged.
The lamp lights red.	The alarm has been acknowledged but the alarm cause remains.
The lamp flashes slowly green, menu window not lit.	The heat pump is in stand-by mode <sup>1)</sup> .
The lamp and menu display not lit.	No voltage to the control unit.

Table 20 Lamp functions

1) Stand-by means that the heat pump is running but no heating or hot water demand exists.

### 11.4 Menu display

Use the menu display in order to:

- View information from the heat pump.
- View available menus.
- Change set values.

### 11.5 Menu button and menu dial

Use to get from *Initial menu* to the menus. Use the menu dial in order to:

- Navigate the menus and get to the setting displays.
  - Turn the dial to see more menus on the same level or change a set value.
  - Press the dial to change to a lower menu level or save a change.

### 11.6 Return button

Use to:

- Go back to the previous menu level.
- Leave a setting display without changing the set value.

### 11.7 Mode button

Use to change type of operation.

- Change type of operation.



The controller language can be changed with the button.

- ▶ Press the button in the initial menu for at least 5 s, then select the required language.

### 11.8 Info button

Use to see information from the control unit about operating mode, temperature, program version, etc.



## 12 Start up

The first time the heat pump is started, a number of settings are displayed automatically so as to facilitate putting it in operation.

Before this stage, the heat pump should be installed in accordance with the previous sections (→ Chapter 9 , → Chapter 10 ). Collector circuits, heating circuits and hot water circuits should be filled and vented.

The settings are also available under ordinary installer menus.



Only functions which are identified by the control unit are displayed in the initial menu.

The start-up menus are available until **Yes** is entered in **Start-up completed**.

- ▶ Read the complete menus before start-up.
- ▶ A selection must be made in **Heat pump x capacity** and **Protective anode installed**.

### Language, Country, Operating mode and Electrical connection

- ▶ Select language for the menus of the control unit (→ Chapter 16.10 ).
- ▶ Select **Country** (→ Chapter 16.10 ).
- ▶ Select operating mode (**L/W + electric additional heat**) (→ Chapter 4.4 , → Chapter 16.7 ).
- ▶ Select **Electrical connection (230V)**.



With the  -button, reinstate the selection that applied to **Language, Country, Operating mode** or **Electrical connection** prior to or during **Start-up**.

### Start-up

Review and adjust, as required, the functions below. See the references for description of the functions.



The selected system solution would normally require a review of more settings than the ones in the start-up.

- ▶ Set **Hot water production** for each heat pump (compressor) (→ Chapter 16.2 ).
- ▶ Set the heat pump output for each heat pump in **Heat pump x capacity** (→ Chapter 16.7 ). See the type plate.
- ▶ **Output limitation electric heater in compressor mode.**  
Set the permitted output at the same time as the compressor is operating (→ Chapter 16.8 ).
- ▶ **Output limitation electric heater when additional heat only.**  
Set the permitted output when the compressor is not operating (→ Chapter 16.8 ).
- ▶ Set **Minimum outdoor temperature** (→ Chapter 16.1 ).
- ▶ Specify if **Groundwater** is used.
- ▶ Set **Circuit 1 Heating \ Type of heating system** (→ Chapter 16.1 ).
- ▶ Set **Circuit 1 Cooling** (if Cooling installed, option), see the option documentation.
- ▶ Set **Circuit 2, 3...** (→ Chapter 16.1 )(option).
  - **Mixing valve mode**
  - **Type of heating system**
  - **Mixing valve running time**
- ▶ Select option in **Protective anode installed** (→ Chapter 16.2 ).
- ▶ Set value for **Pool** (if pool function is installed), see option documentation.
- ▶ Set **Date** (→ Chapter 16.10 ).
- ▶ Set **Time** (→ Chapter 16.10 ).
- ▶ **Start-up completed, Yes/No.**  
The start-up menu will be available until **Yes** is specified.



Under **Protective anode installed** make the appropriate selection to prevent unnecessary alarm messages.

After the start-up menus, the Initial menu is shown in the display. All customer functions are accessible from this menu, whereas the installer menus are accessible only after change of access level.

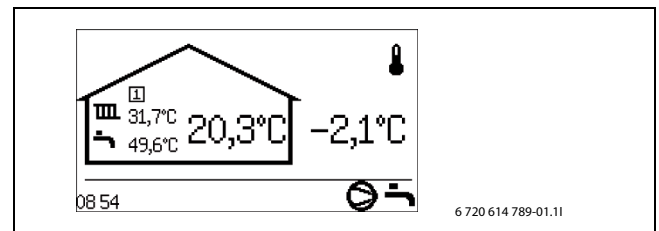

Fig. 40 Starting position

## 13 Function check

### 13.1 Refrigerant circuit



The refrigerant circuit may only be opened by authorised service engineers with refrigeration authorisation.



**DANGER:** Risk of toxic fumes!

The refrigerant circuit contains substances which, when released or exposed to open fire, can form toxic fumes. The fumes block the airways even at low concentrations.

- ▶ If the refrigerant circuit is not air-tight, the room must be vacated immediately and properly aired.

When the heat pump starts and there are quick changes in temperature, bubbles may become visible in the sight glass → Figure 41.

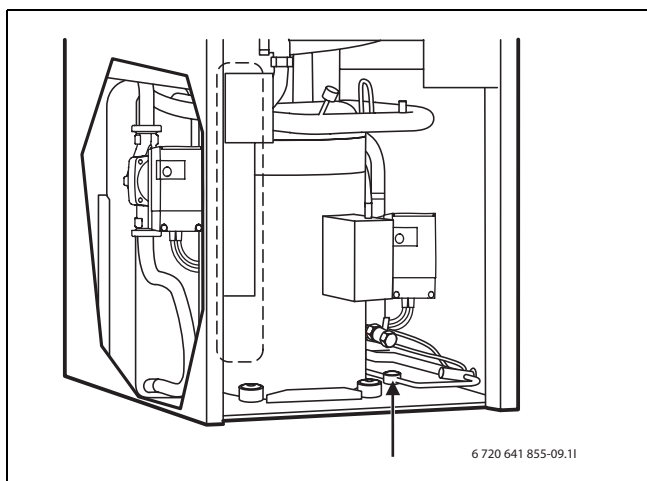

Fig. 41

In the event of constant formation of bubbles:

- ▶ Contact a service representative.

### 13.2 Filling pressure in collector circuit

The level in the vessel should not fall below the min-level 1/3. If the fluid level is too low fill in as below:

The heat pump must be running all the time while filling.

- ▶ Remove the cover on the valve on top of the tank. Now carefully open the valve.
- ▶ Check that the valve is fully open.
- ▶ Fill with anti-freeze (to 2/3) with the help of a clean watering can or similar.
- ▶ Close the valve and finish by screwing on the cover.

### 13.3 Setting heating system operating pressure

Pressure gauge reading	
0.5 bar	Minimum system pressure (when cold)
1 bar	Normal filling pressure
1.5 bar	Maximum system pressure at highest heating water temperature: must not be exceeded (safety valve opens).

Table 21

- ▶ When the gauge is below 0.5 bar (in cold installation): Fill water until the gauge shows approx 1 bar again.
- ▶ If there is a pressure drop: check the expansion vessel and heating system for leaks.

### 13.4 Operating temperatures

Check the temperatures in the heat carrier and collector circuit after 10 minutes of operation:

- Temperature difference between heating system flow and return approx. 7 ... 10 K.
- Temperature difference between collector circuit in and out approx. 2 ... 5 K, recommendation: 2 ... 3 K.

When the temperature difference is too small:

- ▶ Reduce the speed of the corresponding circulation pump (G2 or G3) in order to obtain a lower flow.

When the temperature difference is too great:

- ▶ Increase the speed of the corresponding circulation pump (G2) in order to obtain a greater flow.

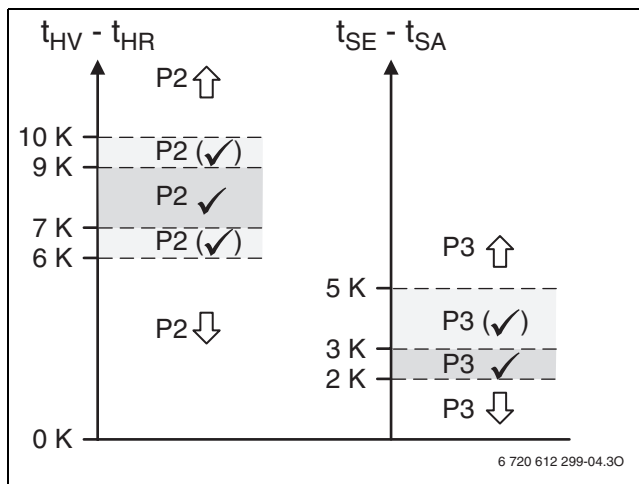

Fig. 42

- [P2] Heat carrier pump G2
- [P3] Collector circuit pump G3
- [t<sub>SA</sub>] Temperature collector circuit out T11
- [t<sub>SE</sub>] Temperature collector circuit in T10
- [t<sub>HV</sub>] Temperature heat transfer fluid out T8
- [t<sub>HR</sub>] Temperature heat transfer fluid in T9

## 14 Installer menus

### 14.1 Access to the functions on Installer level

A four digit access code is required to switch from Customer level to Installer level in the menus. The access code is the present date given as two digits for the month and two digits for the date (for example 0920).

- ▶ Go to **Access level** under **Menu** at Customer level.
- ▶ Enter the four digit access code using the menu dial. Press the menu dial after setting each digit.

**Access = Installer** shown in the menu window.

- ▶ Turn the menu dial to see the menus in the top level.  
All functions at Customer level and Installer level can now be reached.

The control unit returns automatically to Customer level:

- After 20 min (adjustable value, → Chapter 16.7 ).

### 14.2 CANbus LCD

Install/set room sensor for the respective circuit according to separate installer guide. For more information (→ Chapter 9.9.4 ).

### 14.3 Temperature sensor

The control unit controls the production of heat, hot water, etc., after signals from a great number of temperature sensors. Most signals that can appear in the display are listed here.



Complete component names are displayed in the control unit only when needed. If, for example, you are in a menu which refers only to circuit 2, the sensor names are indicated without E12. before the sensor name.

The complete name is always presented in alarm information so as to facilitate troubleshooting. Full names can also be found on drawings and in system solutions.

T1 E11.T1	Flow, circuit 1
T2 E10.T2	Out
T3 E41.T3	Hot water (if hot water production)
T5 E11.TT.T5	Room, circuit 1 (option, CAN-BUS sensor)
T6 E21.T6	Hot gas
T8 E21.T8	Heat transfer fluid out
T9 E21.T9	Heat transfer fluid in
T10 E21.T10	Collector circuit in
T11 E21.T11	Collector circuit out
T1 E12.T1	Flow, circuit 2 (if circuit 2 is used)
T5 E12.TT.T5	Room, circuit 2 (option)

Table 22 Temperature sensor

The sensors name in heat pump 2 is:

E22.T6	Hot gas
E22.T8	Heat transfer fluid out
E22.T9	Heat transfer fluid in
E22.T10	Collector circuit in
E22.T11	Collector circuit out

Table 23 Sensors, heat pump 2

The control unit recognizes which sensors are installed and acknowledges them automatically. An accessory sensor can be deacknowledged manually in the control unit. This makes it possible to remove the sensor from the control unit if it is not used.

### Sensors for options

Circuits 3, 4 etc.

E13.T1	Flow, circuit 3
E13.TT.T5	Room, circuit 3 (accessory)
E14.T1	Flow, circuit 4
E14.TT.T5	Room, circuit 4 (accessory)

Table 24 Sensors, circuit 3, 4

The control unit recognizes which sensors are installed and acknowledges them automatically. An accessory sensor can be deacknowledged manually in the control unit. This makes it possible to remove the sensor from the control unit if it is not used.

## 15 Menu overview

The top menu level for installers is:

- Room temperature
- Hot water
- Holiday
- Energy measurements
- Timers
- External control
- Installer
- Additional heat

- Safety functions
- General
- Alarms
- Access level
- Return to factory settings
- Program version

Access level 0 = Customer

Access level 1 = Installer

HP x = Heat pump 1 or 2 / Compressor 1 or 2

Room temperature		Access level	
Circuit 1 Heating	Type of heating system	1	
	Highest permitted flow temperature T1	1	
	Lowest permitted flow temperature T1	1	
	Heat curve	0	
	Heat curve hysteresis heat pump x	Maximum	1
		Minimum	1
		Time factor	1
	Room sensor	Room temperature influence	1
		Acknowledge room sensor	1
	Room temperature program	Active program	0
		View/edit active program	0
		Room temperature normal	0
		Temperature increase/decrease (no room sensor)	0
		Setting temp. increase/decrease (no room sensor)	1
		> Limit value for left or right end point	1
> Change when much colder/warmer		1	
> Change when colder/warmer		1	
Room temperature influence (no room sensor)		0	
Room temperature exception		0	
Copy to all heating circuits	0		
Circuit 2, 3... (option)	Mixing valve mode	1	
	Type of heating system	1	
	Highest permitted flow temperature T1	1	
	Lowest permitted flow temperature T1	1	
	Heat curve	0	
	Room sensor	As Circuit 1 Heatings	0, 1
	Room temperature program	As Circuit 1 Heating minus Copy to all heating circuits	0, 1
	Regulator settings	P constant	1
		I constant	1
		D constant	1
Minimum PID signal		1	
Maximum PID signal		1	
Mixing valve running time		1	
Mixing valve fully closed		1	
Mixing valve start closing	1		
General	Summer/winter operation	Winter operation	0
		Outdoor temperature limit for change over	0
		Delay before change over to winter operation	1
		Delay before change over to summer operation	1
		Direct start limit for winter operation	1
	Maximum operating time for heating at hot water demand	1	
	Minimum outdoor temperature	1	

Table 25 Room temperature menus

Hot water		Access level
Acknowledge hot water sensor T3		1
Extra hot water	Extra hot water duration	0
	Extra hot water stop temperature	0

Table 26 Hot water menus

Hot water		Access level
Hot water peak	Day of the week	0
	Interval in weeks	0
	Start time	0
	Maximum time	1
	Time for warm-keeping	1
Hot water program	Active program	0
	View/edit active program	0
Hot water mode		0
Hot water settings heat pump x	Hot water production	1
Block heating during hot water demand		1
Maximum operating time for hot water at heating demand		1
Hot water circulation	Hot water circulation pump active	1
	Time settings	1
Protective anode installed		1

Table 26 Hot water menus

Holiday		Access level
Circuit 1 and hot water	Activate holiday function	0
	Start date	0
	Stop date	0
	Room temperature	0
	Copy to all heating circuits	0
	Block hot water production	0
Circuit 2, 3... (option)	Activate holiday function	0
	Start date	0
	Stop date	0
	Room temperature	0

Table 27 Holiday menus

Energy measurements		Access level
Generated energy	Heating	0
	Hot water	0
Consumption electric additional heat	Heating	0
	Hot water	0

Table 28 Energy metering menus

Timers		Access level	
Extra hot water		0	
Hot water peak time for warm-keeping		1	
Alarm mode delay		0	
Operating time for heating at hot water demand		0	
Hot water, operating time at heating demand		0	
Heat pump x timers	Compressor start delay	0	
	Compressor start delay groundwater	1	
	G2 heat carrier pump stop delay	1	
	Block low pressure switch	1	
	Compressor working area timers	Block after hot water production	1
		Delay after temporary stop	1
Block after low outdoor temperature		1	
Additional heat timers	Additional heat start delay	0	
	Delay mixing valve control after additional heat start	0	
	Additional heat program activation delay after low outdoor temperature	1	
	Additional heat start delay after high outdoor temperature	1	
Delay before change over to summer operation		1	
Delay before change over to winter operation		1	
Shut down protection during change over from hot water to heating		1	
Heating start delay		1	
Heating stop delay		1	

Table 29 Timers

## Menu overview

External control			Access level
Heat pump x	External input 1, 2	Invert input	1
		Block additional heat 100% at triggered power guard	1
		Max output additional heat at triggered power guard	1
		Block compressor x	0
		Block additional heat	0
		Block heating at tripped underfloor temperature limiter	0
		Block heating	0
		Room temperature	0
		Block hot water production	0
		Start collector circuit pump	1
		Alarm at low pressure in collector circuit	1
External input circuit 2, 3...		Invert input	1
		Block heating at tripped underfloor temperature limiter	1
		Block heating	0
		Room temperature	0

Table 30 External control menus

Installer			Access level
General	Anti-seizure mode	Day of the week	1
		Start time	1
	Highest permitted flow temperature T1		1
	Operating mode		1
	Groundwater	Groundwater	1
		Compressor start delay groundwater	1
	Display light switch off delay		1
Time for reset of access level		1	
Heat pump x capacity			1
Connected I/O boards	Shows which circuit boards are connected and their program version		1
Compressor working area	Outdoor stop function activated		1
Generated energy	Heating		1
	Hot water		1
Operating times and consumptions	Displays the total operating times of the compressor and additional heat. Short term measurements can be made.		1
Temperatures	All connected temperature sensors are displayed and can also be corrected.		1
Programmable outputs			1
Inputs	Shows the status of all connected inputs (pressostats, motor cut-out, external inputs, etc.)		1
Outputs	Manual operation of and status of constituent components (pumps, valves, additional heat, alarm indication etc.)		1
Circulation pumps	Heating circuit pump G1	Operation alternative	1
	Heat carrier pump G2	Operation alternative	1
		Pump speed E2x	1
		Regulator settings	1
Collector circuit pump G3	Operation alternative	1	

Table 31 Installer menus

Additional heat			Access level
Additional heat general	Start delay		1
	Allow additional heat timer during energy supply cut-off		1
	Additional heat only		1
	Block additional heat		1
	Maximum outdoor temperature for additional heat		1

Table 32 Additional heat menus

Additional heat			Access level
Electric additional heat	Electric heater connection	Connected output	1
		Output limitation in compressor mode	1
		Output limitation when additional heat only	1
		Output limitation in hot water mode	1
	Regulator settings	P constant	1
		I constant	1
	D constant	1	
	Minimum PID signal	1	
	Maximum PID signal	1	
Hot water electric heater	Acknowledge hot water additional heat		
Additional heat program	Active program		1
	View/edit active program		1
	Outdoor temperature limit for deactivation of time control		1

Table 32 Additional heat menus

Safety functions			Access level
Setting collector circuit in T10	Lowest permitted temperature E21.T10		1
	Lowest permitted temperature E22.T10		1
	Hysteresis alarm reset		1
	Number of warnings before alarm		1
Setting collector circuit out T11	Lowest permitted temperature E21.T11		1
	Lowest permitted temperature E22.T11		1
	Hysteresis alarm reset		1
	Number of warnings before alarm		1

Table 33 Safety functions menus

General			Access level
Room sensor settings	Show outdoor temperature in room sensor		0
Set date			0
Set time			0
Summer/winter time			0
Display contrast			0
Language			0
Country			1

Table 34 General menus

Alarms			Access level
Information log			0
Delete information log			0
Alarm log			0
Delete alarm log			0
Alarm history			1
Alarm indication	Alarm buzzer signal	Interval	0
		Blocking time	0
	Alarm indication control unit	Block alarm buzzer	0
	Alarm indication room sensor	Block alarm indicator lamp	0
	General alarm level	Alarms and warnings	1

Table 35 Alarm menus

Access level	Access level
Access level	0, 1

Table 36 Access level menu

Return to factory settings	Access level
Return to factory settings	0, 1

Table 37 Return to factory settings menu

## 16 Settings

### 16.1 Room temperature

Press the  button in the standard display to open the main menu. Select **Room temperature** to adjust the heating.

The following options are available under **Room temperature**:

- **Circuit 1 Heating**
- **Circuit 2, 3...**
- **General**

#### > Circuit 1 Heating

##### >> Type of heating system

Factory setting	Underfloor
Alternative	Radiator/Underfloor

Table 38 Type of heating system

- ▶ Select type of heating system, **Radiator** or **Underfloor**.

The factory settings for the **Radiator** have a curve value (flow temperature) of 22 °C at 20 °C an outdoor temperature, 37.4 °C at -2.5 °C and 60 °C at -35 °C at an outdoor temperature (the high point of the curve).

The factory settings for the **Underfloor** have a curve value (flow temperature) of 22 °C at 20 °C outdoor temperature, 27.2 °C at -2.5 °C and 35 °C at -35 °C outdoor temperature.

At a temperature higher than 20 °C, the same curve value applies as for 20 °C.



The right point of the curve (-35 °C) can be changed in **Minimum outdoor temperature** (→ Chapter 16.1 ). Set value applies for all heat curves. A change of the right point affects the flow temperature for all outdoor temperatures that are lower than the set temperature.

##### >> Highest permitted flow temperature T1

Factory setting	80.0 °C
Lowest value	1)
Highest value	100.0 °C

Table 39 Radiator

Factory setting	45.0 °C
Lowest value	1)
Highest value	45.0 °C

Table 40 Underfloor

1) The value that is set in **Lowest permitted flow temperature T1**.

##### >> Lowest permitted flow temperature T1

Factory setting	10.0 °C
Lowest value	10.0 °C
Highest value	80.0 °C

Table 41 Radiator

Factory setting	10.0 °C
Lowest value	10.0 °C
Highest value	45.0 °C

Table 42 Underfloor

- ▶ Set the highest and lowest permitted temperature for T1. Ensure that the value corresponds with the selected curve and possible curve adjustments.
- ▶ Check also that the highest temperature T1 with **Underfloor** does not exceed the permitted value for the type of floor used.



The heat curve forms the basis for set point value calculation of the flow temperature. Most other temperatures for heating that are set refer to room temperature. These values are transformed by the control unit into flow temperature values.

##### >> Heat curve

The heat curve constitutes the basis for the control unit's control of the temperature on the heating water to the circuit and indicates how high it needs to be in relation to the outdoor temperature. The control unit increases the temperature of the heating water when the outdoor temperature drops. The temperature of the heating water out to the circuit, i.e. the flow temperature is measured by sensor T1 for circuit 1 (full name E11.T1) and sensor T1 for circuit 2 (full name E12.T1).

Each circuit is controlled by its own heat curve. The installer sets the type of heating for each circuit, that is **Radiator** or **Underfloor**. The curve for **Underfloor** has lower values because the floors do not tolerate such high temperatures.

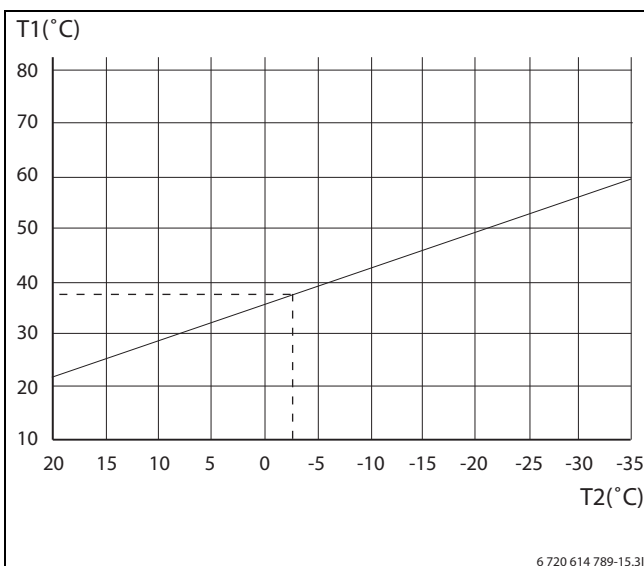

Fig. 43 Radiator

The figure indicates the factory setting curve for a radiator circuit. At -2.5 °C the flow set point is 37.4 °C.

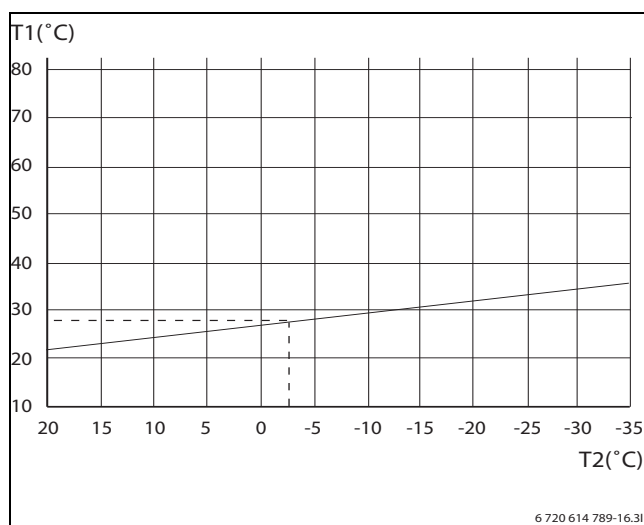

Fig. 44 Floor

The figure indicates the factory setting curve for an underfloor circuit. At -2.5 °C the flow set point is 27.2 °C.



### Setting of heat curve



If the heat curve has been set too high, the display will show the message **Too high heat curve setting**.

- ▶ Change the heat curve setting.

A heat curve is set for each circuit. If the room temperature is perceived to be too high or too low in the circuit, it is preferable to adjust the curve.

The curve can be changed in different ways. The slope of the curve can be changed by offsetting the flow temperature upwards or downwards on the left-hand side (the value at outdoor temperature 20 °C, factory value 22.0 °C) as well as the right-hand side (the value at outdoor temperature -35 °C, factory setting 60.0 °C). In addition, the curve can be affected by every 5th outdoor temperature degree.

The value at 0 °C is displayed above the curve's left-hand point, factory value 35.7 °C.

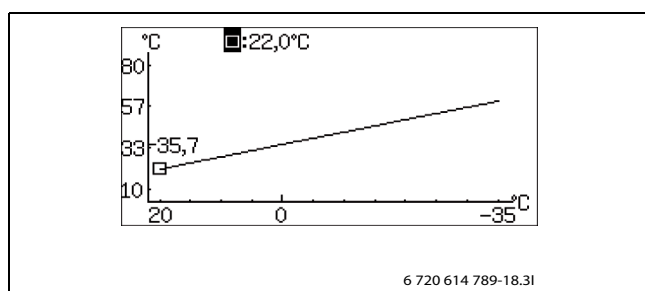

Fig. 45 Settings window Heat curve (radiator)

Change the left point:

- ▶ Press the menu dial when the square is marked. The value is marked.

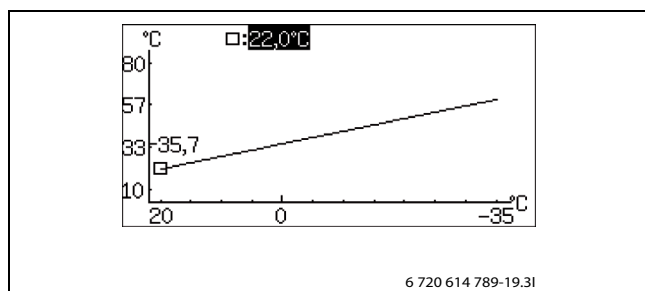

Fig. 46

- ▶ Turn the menu dial to change the value. Press the dial to save or use to return without saving.

In the window, the square is marked again and any changed values are displayed after the square. In addition, the curve is updated according to the new value.

Change the right point:

- ▶ Turn the menu dial when the square is marked. The upper square is changed to outdoor temperature with the corresponding curve value after the colon. The circle marks the relevant curve position.
- ▶ Continue to turn the dial until it shows a square before the colon.
- ▶ Press the dial to mark the value.

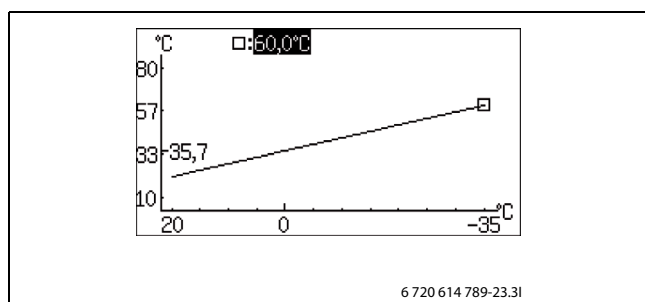

Fig. 47

- ▶ Turn the menu dial to change the value. Press the dial to save or use to return without saving. In the window, the square is marked again and any changed values are displayed after the square. In addition, the curve is updated according to the new value.

Change a specific value, for example the value at an outdoor temperature of 0 °C:

- ▶ Turn the menu dial when the square is marked until 0 °C is marked (→ Figure 48).
- ▶ Press the dial to mark the value.

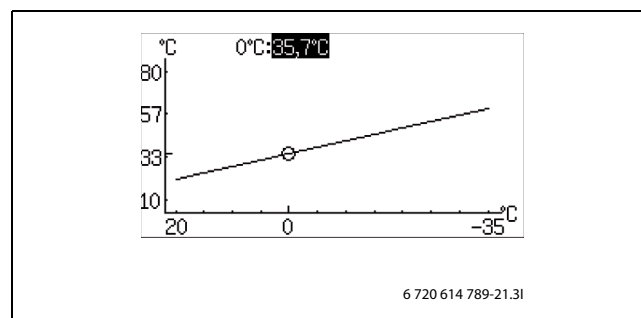

Fig. 48

- ▶ Turn the menu dial to change the value.

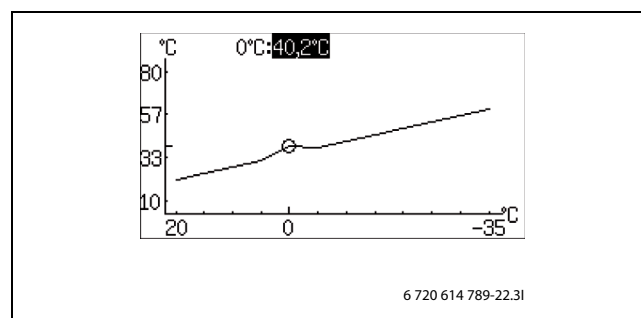

Fig. 49

- ▶ Press the dial to save or use to return without saving.
- ▶ Use to leave the curve setting window and return to the menu.



Recommendations:

- ▶ Increase the value of the right point if it feels too cold at low outdoor temperatures.
- ▶ Increase the value of curve at 0 °C if it feels a little cold at outdoor temperatures around 0.
- ▶ Increase or decrease the value of the curve equally at the right and left points to fine adjust the heat (the curve is offset parallel).

### >> Heat curve hysteresis heat pump x

#### >>> Maximum

Factory setting	25.0K
Lowest value	The value in Minimum
Highest value	30.0K

Table 43 Maximum hysteresis

- ▶ Set how big the maximum hysteresis for the flow temperature can be.

#### >>> Minimum

Factory setting	4.0K
Lowest value	2.0K
Highest value	The value in Maximum

Table 44 Minimum hysteresis

- ▶ Set how big the minimum hysteresis for the flow temperature can be.

>>> Time factor

Factory setting	20.0
Lowest value	1.0
Highest value	30.0

Table 45 Time factor

- ▶ Select how long the compressor should be on or off in heating mode. Higher set values result in fewer compressor starts and stops, which achieves higher economy. However, more pronounced temperature fluctuations in the heating system may result than with lower values.

>> Room sensor

> Room temperature influence

Factory setting	3.0
Lowest value	0.0
Highest value	10.0

Table 46 Room temperature influence

- ▶ Set how much a 1 K (°C) difference in room temperature should influence the set point value for the flow temperature. Example: at a 2 K (°C) deviation from the set room temperature, the set point value for the flow temperature is changed by 6 K (°C) (2 K deviation \* factor 3 = 6 K).

The menu is displayed only if a room sensor is installed.

>>> Acknowledge room sensor

Factory setting	Yes (if correctly installed)
Alternative	Yes/No

Table 47 Acknowledge room sensor

- ▶ Indicate **No** only if the room sensor, even if it is installed, should not be used.

>> Room temperature program

Factory setting	HP optimized
Alternative	<ul style="list-style-type: none"> <li>• HP optimized</li> <li>• Program 1</li> <li>• Program 2</li> </ul>

Table 48 Program selection, circuit 1

- ▶ Choose if the circuit should be controlled with a program or not.

**Optimised operation**

This means that the control unit is only controlled by the flow set point value (→ Chapter 16.1.1 ), without programmed changes during the day. Optimised operation provides the best comfort and energy savings in the vast majority of cases.

**Program 1 and 2**

These selections provide an opportunity to define user programs for time control by adjusting the start and stop times, as well as a normal and an exception temperature.

Program	Day	Start	Stop
Program 1, 2	Mon - Sun	5:30	22:00

Table 49 Program 1 and 2

To set the desired time of day:

- ▶ Select **Program 1** or **Program 2**.
- ▶ Go to menu **View/edit active program**.
- ▶ Select day by turning the menu dial.

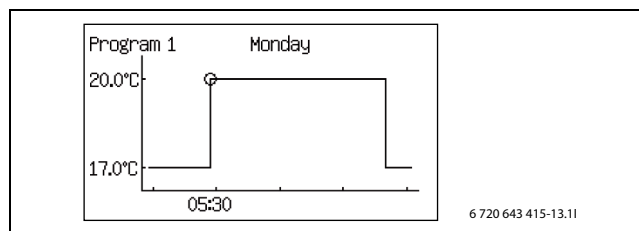

Fig. 50

- ▶ Press the menu dial to mark the value to be changed.

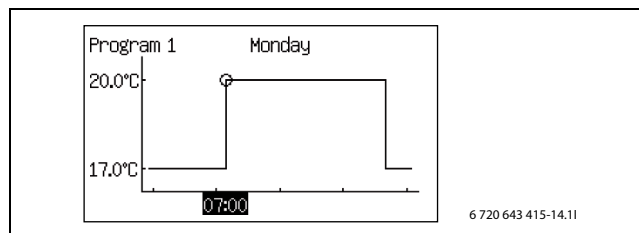



Fig. 51

- ▶ Turn the menu dial until the desired setting has been selected.
- ▶ Then press the menu dial.
- ▶ Turn the menu dial to be able to set additional values in the same way as above.
- ▶ Go back one step with .
- ▶ Select **Saving alternative**:
  - Return without saving
  - Program 1
  - Program 2

The set changes are saved as a selected program or not at all.

- ▶ To adjust the normal temperature, proceed to menu **Room temperature normal**.
- ▶ To adjust the exceptional temperature, proceed to menu **Room temperature exception**.

**Room temperature program when there is a room sensor:**

>> Room temperature program

>>> Active program

If a program is selected, the following (if the menu button is turned) is displayed:

>>> View/edit active program

>>> Room temperature normal

Factory setting	20.0°C
Lowest value	10.0°C
Highest value	35.0°C

Table 50 Room temperature, normal

- ▶ Set the desired set point for the room temperature.

>>> Room temperature during time program

Factory setting	17.0°C
Lowest value	10.0°C
Highest value	30.0°C

Table 51 Room temperature, exception

- ▶ Set the temperature that should apply as exceptional temperature in the program. The menu is displayed only if **Program 1** or **Program 2** has been selected.

## &gt;&gt;&gt; Copy to all heating circuits

Factory setting	No
Alternative	No/Yes

Table 52 All circuits

- ▶ Select **Yes** to have the same control for all installed circuits. The menu is displayed only under **Circuit 1**.

**Room temperature program when there is no room sensor:**

## &gt;&gt; Room temperature program

## &gt;&gt;&gt; Active program

## &gt;&gt;&gt; View/edit active program

The same as when there is a room sensor, see above.

## &gt;&gt;&gt; Room temperature normal

Factory setting	20.0 °C
Lowest value	10.0 °C
Highest value	35.0 °C

Table 53 Room temperature, normal

- ▶ Set the measured value in the room. The indicated value is used by temperature programs to calculate the difference between normal and exceptional temperature.

## &gt;&gt;&gt; Temperature increase/decrease

Factory setting	=
Alternative	- , - , = , + , ++

Table 54 Room temperature increase/decrease

- ▶ Use this function to adjust the room temperature so that the normal room temperature (see the previous menu) becomes the desired temperature.
- ▶ Use this function to simply increase or decrease the heat when there are no room sensors.
  - - gives approx. 1 °C lower room temperature.
  - gives approx. 0.5 °C lower room temperature.
  - + gives approx. 0.5 °C higher room temperature.
  - ++ gives approx. 1 °C higher room temperature.

## &gt;&gt;&gt; Setting temp. increase/decrease

## &gt;&gt;&gt;&gt; Limit value for left or right end point

Factory setting	0.0 °C
Lowest value	-10.0 °C
Highest value	15.0 °C

Table 55 Heating increase/decrease limit value

- ▶ Set which outdoor temperature should be the limit value for the end point that should be adjusted when increase/decrease is requested. At outdoor temperatures lower than the limit value, the flow temperature in the right end point (-35 °C) of the heat curve is affected, with change indicated in %, see below. At outdoor temperatures higher than the limit value, the flow temperature in the left end point (+20 °C) of the heat curve is affected, with change indicated in %, see below.

## &gt;&gt;&gt;&gt; Change when much colder/warmer

Factory setting	8%
Lowest value	1%
Highest value	20%

Table 56 Change when much colder/warmer

- ▶ Set how many % the flow temperature in the applicable end point of the heat curve should change down or up when - - or ++ is selected in **Temperature increase/decrease**.

## &gt;&gt;&gt;&gt; Change when colder/warmer

Factory setting	3%
Lowest value	1%
Highest value	20%

Table 57 Change when colder/warmer

- ▶ Set how many % the flow temperature in the applicable end point of the heat curve should change down or up when - or + is selected in **Temperature increase/decrease**.

## &gt;&gt;&gt; Room temperature influence

Set in the same way as in menu **Room sensor** (→ Chapter 16.1 ). The setting is used in the temperature program to calculate how the flow line temperature is affected when **Room temperature exception** is to apply.

## &gt;&gt;&gt; Room temperature during time program

## &gt;&gt;&gt; Copy to all heating circuits

The same as when there is a room sensor, see above.



It always takes some time for a change of a heating setting, e.g. an increase or decrease in room temperature, to apply. The same applies in the event of a quick change of the outdoor temperature. This is why you should always wait for at least 24 hours before making a new change.

## &gt; Circuit 2, 3...

Make the settings for the first mixed circuit under **Circuit 2**. Other circuits are displayed only if they exist. The same functions apply to these as the functions for circuit 2.

## &gt;&gt; Mixing valve mode

Factory setting	Off
Alternative	Heating/Off

Table 58 Mixing valve operating mode

- ▶ Select **Off** if the circuit is not ready-built or needs to be turned off temporarily or should not be used.

## &gt;&gt; Type of heating system

Factory setting	Underfloor
Alternative	Radiator/Underfloor

Table 59 Type of heating system

- ▶ Select type of heating system.

The factory settings for the **Radiator** have a curve value (flow temperature) of 22 °C at 20 °C an outdoor temperature, 37.4 °C at -2.5 °C and 60 °C at -35 °C at an outdoor temperature (the high point of the curve).

The factory settings for the **Underfloor** have a curve value (flow temperature) of 22 °C at 20 °C outdoor temperature, 27.2 °C at -2.5 °C and 35 °C at -35 °C outdoor temperature.

At a temperature higher than 20 °C, the same curve value applies as for 20 °C.



The right point of the curve (-35 °C) can be changed in **Minimum outdoor temperature** (→ Chapter 16.1 ). Set value applies for all heat curves. A change of the right point affects the flow temperature for all outdoor temperatures that are lower than the set temperature.

>> Highest permitted flow temperature T1

Factory setting	80.0 °C
Lowest value	1) <sup>1)</sup>
Highest value	100.0 °C

Table 60 Radiator

Factory setting	45.0 °C
Lowest value	1) <sup>1)</sup>
Highest value	45.0 °C

Table 61 Underfloor

<sup>1)</sup> The value that is set in **Lowest permitted flow temperature T1**.

>> Lowest permitted flow temperature T1

Factory setting	10.0 °C
Lowest value	10.0 °C
Highest value	80.0 °C

Table 62 Radiator

Factory setting	10.0 °C
Lowest value	10.0 °C
Highest value	45.0 °C

Table 63 Underfloor

- ▶ Set the highest and lowest permitted temperature for T1. Ensure that the value corresponds with the selected curve and possible curve adjustments.
- ▶ Check also that the highest temperature T1 with **Underfloor** does not exceed the permitted value for the type of floor used.

>> Heat curve

The settings are the same as for **Circuit 1**.

>> Room sensor

The settings are the same as for **Circuit 1**.

>> Room temperature program

The settings are the same as for **Circuit 1**, except that **Copy to all heating circuits** is not included.

>> Regulator settings

The mixing valve is controlled with PID regulator in order to reach the flow set point value when there is a need. The signal determines how much the opening of the mixing valve should change. It is calculated with short time intervals.

>> Regulator settings

>>> P constant

Factory setting	1.0
Lowest value	0.1
Highest value	30.0

Table 64 P constant

>>> I constant

Factory setting	300.0
Lowest value	5.0
Highest value	600.0

Table 65 I constant

>>> D constant

Factory setting	0.0
Lowest value	0.0
Highest value	10.0

Table 66 D constant

>>> Minimum PID signal

Factory setting	0%
Lowest value	0%
Highest value	100%

Table 67 Minimum PID signal

>>> Maximum PID signal

Factory setting	100%
Lowest value	0%
Highest value	100%

Table 68 Maximum PID signal

>>> Mixing valve running time

Factory setting	300s / 05:00
-----------------	--------------

Table 69 Mixing valve running time

- ▶ Set the run time that is indicated on the mixing valve and indicate value in number of minutes.



If there is no time indication on the mixing valve, run it manually (→ Chapter 16.7 ) and measure how long it takes to go from fully closed to a fully open mixing valve (the mixing valve stops sounding and the endposition switch switches off).

>>> Mixing valve fully closed

Factory setting	2.0K
Lowest value	1.0K
Highest value	10.0K

Table 70 Mixing valve fully closed

- ▶ Set how many K ( °C) below the maximum permitted flow temperature T1 the mixing valve is to be fully closed. The maximum flow temperature is different depending on the type of heating system (radiator or underfloor). With an underfloor system, the mixing valve should be fully closed at 45 °C-2K=43 °C (with factory settings).

>>> Mixing valve start closing

Factory setting	2.0K
Lowest value	1.0K
Highest value	10.0K

Table 71 Start closing mixing valve

- ▶ Set how many K ( °C) below the value for fully closed mixing valve the closure of the mixing valve should begin. The result is 43 °C-2K=41 °C (with the factory settings for underfloor heating).

### 16.1.1.1 Should value

The heating circuit's set point value is the temperature of the flow that the heat pump attempts to maintain. Sometimes, the measured actual value fluctuates a bit upward and downward depending on changes in the outdoor temperature or a large hot water demand.



The set point value specified by the customer/installer is most often the room temperature, which is recalculated by the control unit into a corresponding flow temperature set point value. Under normal conditions, 1 K (°C) in room temperature corresponds to approx. 3 K (°C) in flow temperature.

The set point value is normally based on:

- Current curve value (the flow temperature at the current outdoor temperature according to the applicable heat curve).
- Current curve influence through:
  - Room sensor
  - Holiday
  - Active program
  - External control

#### Set point value calculation

The set point value for the heating circuit is the current curve value adjusted with active curve influence, if any such exists.

Priority order for curve influence is:

- External control
- Active program
- Holiday

Only one of these can be active. How big the influence should be and when to exercise it is set in the respective function.

#### Fixed set point value

A fixed set point value (not curve-based) applies in the event of:

- External set point value. The set point value is determined according to input signal 0-10V where 1V is 10 °C and 10V is 80 °C (0V triggers an alarm).

#### Set point value limitation

The calculated set point value is always checked against the permitted temperature limits.

The applicable set point value T1 for **Circuit 1** and the measured actual value for T1 are used to activate and deactivate the heat demand.

The following applies to **Circuit 2, 3...**: When the actual value for the mixed circuit's T1 is low in relation to the set point value, more heating water is shunted into the circuit so as to maintain the set point value.

If the flow temperature has been below the set point value for a certain period of time, there is heat demand and the compressor produces heat before there is a too significant temperature reduction indoors. This happens until the flow temperature is a couple of degrees higher than the set point value. (Or because **Maximum operating time for heating at hot water demand** has passed.)

Heating demand is not active during summer operation.

#### > General

#### >> Summer/winter operation

#### >>> Winter operation

Factory setting	Automatic
Alternative	On/Automatic/Off

Table 72 Summer/winter operation

If **On** is selected, the heat pump is constantly in winter operation and heat and hot water are always produced. **Off** signifies constant summer operation; only hot water is produced. **Automatic** signifies change-over at the set outdoor temperature.

#### >>> Outdoor temperature limit for change over

Factory setting	18 °C
Lowest value	5 °C
Highest value	35 °C

Table 73 Change over temperature

The menu is displayed only if **Automatic** has been selected in **Winter operation**.

#### >>> Delay before change over to winter operation

Factory setting	4h
Lowest value	1h
Highest value	48h

Table 74 Delay before change over to winter operation

#### >>> Delay before change over to summer operation

Factory setting	4h
Lowest value	1h
Highest value	48h

Table 75 Delay before change over to summer operation

#### >>> Direct start limit for winter operation

Factory setting	13 °C
Lowest value	5 °C
Highest value	17 °C

Table 76 Direct start limit



In the event of change over between winter and summer operation and vice versa, there is a certain delay to prevent constant starting and stopping of the compressor when the outdoor temperature oscillates around the temperature limit. Below the direct start limit, the control unit changes over to winter operation without delay.

#### >> Maximum operating time for heating at hot water demand

The menu is not displayed if **Block heating during hot water demand** is set to **Yes** (→ Chapter 16.2 ).

Factory setting	20min
Lowest value	0min
Highest value	120min

Table 77 Operating time heating

#### >> Minimum outdoor temperature

Factory setting	-35,0 °C
Lowest value	-35,0 °C
Highest value	-10,0 °C

Table 78 Lowest outdoor temperature

- ▶ Set the minimum outdoor temperature for the heat curve.

## 16.2 Hot water

Under **Hot water**, there are functions to:

- **Acknowledge hot water sensor T3**
  - **Extra hot water**
  - **Hot water peak**
  - **Hot water program**
  - **Hot water mode**
  - **Hot water settings heat pump x**
  - **Block heating during hot water demand**
  - **Maximum operating time for hot water at heating demand**
  - **Hot water circulation**
  - **Protective anode installed**
- > **Acknowledge hot water sensor T3**

Factory setting	Yes (if correctly installed)
Alternative	Yes/No

Table 79 Acknowledge hot water sensor

### > Extra hot water

#### >> Extra hot water duration

Factory setting	0h
Lowest value	0h
Highest value	48h

Table 80 Extra hot water duration

- ▶ Set the duration of extra hot water production.

#### >> Extra hot water stop temperature

Factory setting	65 °C
Lowest value	50 °C
Highest value	65 °C

Table 81 Extra hot water stop temperature

- ▶ Set the stop temperature for extra hot water.

Additional amount of hot water is produced by temporarily increasing the temperature of the hot water during the set number of hours to the indicated stop temperature.

The heat pump starts the function directly and uses the compressor first and then the additional heat source to increase the temperature. When the desired number of hours have passed, the heat pump returns to normal hot water mode.



**DANGER:** Risk of burn injuries.

- ▶ Use a mixing valve when the hot water temperature exceeds 60 °C.

### > Hot water peak

**Hot water peak** means a temporary increase in the hot water temperature to approx. 65 °C for thermal elimination of bacteria (pasteurisation).

The **Hot water circulation pump** is controlled by the control unit during the hot water peak.

For the hot water temperature increase, the compressor is used first; the additional heat source then continues alone.

#### >> Day of the week

Factory setting	None
Alternative	None, Day, All

Table 82 Day of the week

- ▶ Set the day on which the hot water peak should take place. **None** means that the function is disabled. **All** means that a hot water peak takes place every day.  
If hot water peak is deactivated comfort mode must be selected in the menu hot water mode.

- ▶ Select **None** if electric additional heat in the hot water heater is missing.

#### >> Interval in weeks

Factory setting	1
Lowest value	1
Highest value	4

Table 83 Week interval

- ▶ Set how often a hot water peak should take place.
  - 1 means a hot water peak every week.
  - 2 means that a hot water peak takes place in all even weeks of the year, i.e. in week 2, 4, 6, etc.
  - 3 means week 3, 6, 9, etc.
  - 4 means week 4, 8, 12, etc.

#### >> Start time

Factory setting	3:00
Lowest value	0:00
Highest value	23:00

Table 84 Start time

- ▶ Set the time of the hot water peak.

#### >> Maximum time

Factory setting	3.0h
Lowest value	1.0h
Highest value	5.0h

Table 85 Maximum time

#### >> Time for warm-keeping

Factory setting	1.0h
Lowest value	1.0h
Highest value	Maximum time - 1h

Table 86 Time for warm-keeping

- ▶ Set **Maximum time** and **Time for warm-keeping**.  
The hot water peak is activated on the selected day and at the selected time. It continues until the stop temperature has been reached plus the time for warm-keeping. The hot water peak cannot continue longer than the set **Maximum time**. If it is cancelled because the maximum time has expired, a message is shown in the display and a new attempt is made after 24 hours.

### > Hot water program

**Program 1** and **Program 2** enables you to block hot water production during the set time.

#### >> Active program

Factory setting	Always hot water
Alternative	<ul style="list-style-type: none"> <li>• Always hot water</li> <li>• Program 1</li> <li>• Program 2</li> </ul>

Table 87 Hot water program

#### >> View/edit active program

The menu is displayed only if **Program 1** or **Program 2** has been selected. Programs are changed in the same way as for **Room temperature program** (→Chapter 16.1 ).

**> Hot water mode**

Factory setting	Economy
Alternative	Economy/Comfort

Table 88 Hot water mode

- ▶ Select hot water mode.

**Economy** means that the hot water is permitted to cool slightly before hot water production starts compared to **Comfort**. Heating stops at a slightly lower temperature.

- ▶ Change to **Comfort** if more or hotter hot water is desired. This setting must be used if electric additional heat is missing or if the hot water circulation is used, when the temperature in the hot water circulation is otherwise too low.

**> Hot water settings heat pump 1**

In certain countries there are requirements regarding the lowest hot water temperature in buildings. Check that the settings in Economy and Comfort mode conform to the applicable regulations.

**>> Hot water production**

Factory setting	Yes
Alternative	No/Yes

Table 89 Hot water production

**> Hot water settings HP 2**

Heat pump 2 has factory setting **No** for **Hot water production**. This value must not be changed.

**> Block heating during hot water demand**

Factory setting	No
Alternative	Yes/No

Table 90 Block the heat

- ▶ Select **Yes** if the hot water demand must always be satisfied before the heat demand.
- ▶ Select **No** if hot water production should be interrupted after a certain time in event of a heat demand.
- ▶ In **No** also set the duration that hot water production may occur for during the heat demand.

**>> Maximum operating time for hot water at heating demand**

Factory setting	30 min
Lowest value	5 min
Highest value	60 min

Table 91 Operating time hot water

**> Hot water circulation (accessory)**

A special circulation pump for hot water, E41.G6, can be installed. It is subject to time control, i.e., it can be activated during parts of the day. Due to the circulation, the hot water reaches the tapping place faster.

**>> Hot water circulation pump active**

Factory setting	No
Alternative	No/Yes

Table 92 Hot water circulation pump active

- ▶ Indicate **Yes** if there is circulation pump. Time settings can then be made.
- ▶ In **Yes**, change hot water mode to comfort mode.

**>> Time settings**

Start time	Stop time
00:00	24:00

Table 93 Time settings

- ▶ Set up to four separate intervals.
- ▶ To change time: turn the menu dial until the desired time appears. Push the menu dial to continue to the next setting field.
- ▶ Go back to the previous field by using .
- ▶ Press the menu dial in the last setting field to save settings. Hot water circulation takes place every day during the set periods.

**> Protective anode installed**

Factory setting	1)
Alternative	Yes/No

Table 94 Anode installed

**1) value set during Start-up**

Change the value if there has been a change since start-up.

- ▶ Change to **No** if no anode exists. Normally, there is an anode in the hot water heater in order to protect it against corrosion. If the anode breaks, it must be fixed to prevent the hot water heater from being damaged. The control unit alerts when the anode is broken.

### 16.3 Holiday

During holidays (absence), the heating can, for example, be kept at a lower or higher level and hot water production can be switched off. *Start* and *Stop date*, *Room temperature* and *Block hot water production* are only displayed if the holiday function is activated.

#### > Circuit 1 and hot water

##### >> Activate holiday function

Factory setting	No
Alternative	No/Yes

Table 95 Holiday function

##### >> Start date

##### >> Stop date

- ▶ Set start and stop date for the desired period. Format yyyy-mm-dd. The period starts and ends at 00:00. Both the start and end date are included in the period.
- ▶ Terminate the period prematurely by indicating **No** in the menu **Activate holiday function**.

##### >> Room temperature

- ▶ Set the room temperature that should apply to the circuit during the period.

Factory setting	17 °C
Lowest value	10 °C
Highest value	35 °C

Table 96 Room temperature, holiday

##### >> Copy to all heating circuits

Factory setting	No
Alternative	Yes/No

Table 97 Copy circuits

##### >> Block hot water production

Factory setting	No
Alternative	Yes/No

Table 98 Block hot water

#### > Circuit 2, 3... (optional)

##### >> Activate holiday function

##### >> Start date

##### >> Stop date

##### >> Room temperature

- ▶ Set the values in the same way as for **Circuit 1 and hot water**.

### 16.4 Energy measurements



Energy is measured per compressor; the calculated results are added prior to being displayed.

#### > Generated energy

This displays **Generated energy** in kWh divided into **Heating** and **Hot water**.

#### > Consumption electric additional heat

This displays **Consumption electric additional heat** in kWh divided into **Heating** and **Hot water**.



## 16.5 Timers

The control unit shows the timers that are in operation. There are a number of timers for, e.g., delays of different types, but also for extra hot water, hot water peak, etc. A number of these times are set under

customer or installer, whereas others have a set factory value which cannot be changed. Level shows at what level the setting can be made. 0 = Customer, 1 = Installer, 3 = Factory.

Timers	Setting	F value	Level
Extra hot water	Extra hot water duration	0h	0, 1
Hot water peak time for warm-keeping	Hot water\Hot water peak\Time for warm-keeping	1.0h	1
Alarm mode delay		1.0h	3
Operating time for heating at hot water demand	Room temperature\General\Maximum operating time for heating at hot water demand	20min	1
Hot water, operating time at heating demand	Hot water\Maximum operating time for hot water at heating demand	30 min	1
Heat pump x timers			
> Compressor start delay		10min	3
> Compressor start delay groundwater	Installer\General\Groundwater\Compressor start delay	15s	1
> G2 heat carrier pump stop delay		5min	3
> Block low pressure switch		150s	3
> Compressor working area timers			
>> Block after hot water production		120s	3
>> Delay after temporary stop		60min	3
>> Block after low outdoor temperature		30 min	3
Additional heat timers			
> Additional heat start delay	Additional heat\Additional heat general\Start delay	60min	1
> Additional heat start delay after high outdoor temperature		30 min	3
> Delay mixing valve control after additional heat start	Additional heat\Mixed additional heat\Delay mixing valve control after additional heat start	20min	1
> Additional heat program activation delay after low outdoor temperature		15min	3
Delay before change over to summer operation	Room temperature\General\Summer/winter operation\Delay before change over to summer operation	4h	1
Delay before change over to winter operation	Room temperature\General\Summer/winter operation\Delay before change over to winter operation	4h	1
Shut down protection during change over from hot water to heating		300s	3
Heating start delay <sup>*)</sup>		3min	-
Heating stop delay <sup>*)</sup>		3min	-

Table 99 Timers

<sup>\*)</sup> Between compressors/heat pumps

## 16.6 External control

When an external input is connected, the control unit performs functions which are set to **Yes** or is separated from 0 (**Room temperature**). When the external input is no longer connected, the control unit returns to normal mode. Only installed functions are displayed.

This is where the functions for the external inputs 1 and 2 per heat pump and the external inputs for circuits 2, 3, etc. are located.

### > Heat pump x

#### >> External input 1, 2

##### >>> Invert input

Factory setting	No
Alternative	No/Yes

Table 100 Invert input

► Select **Yes** if the input signal is to be reversed (i.e. activated with open contact).

##### >>> Block additional heat 100% at triggered power guard

Factory setting	No
Alternative	Yes/No

Table 101 Block additional heat completely when power guard is triggered

##### >>> Max output additional heat at triggered power guard

Factory setting	Off (0,0kW)
Lowest value	Off (0,0kW)
Highest value	9.0kW

Table 102 Max output additional heat power guard is triggered

##### >>> Block compressor x

Factory setting	No
Alternative	No/Yes

Table 103 Blocking

##### >>> Block additional heat

Factory setting	No
Alternative	No/Yes

Table 104 Blocking

##### >>> Block heating at tripped underfloor temperature limiter

Factory setting	No
Alternative	No/Yes

Table 105 Blocking

>>> **Block heating**

Factory setting	No
Alternative	No/Yes

Table 106 Blocking

>> **Room temperature**

Factory setting	No (0.0 °C)
Lowest value	10.0 °C
Highest value	35.0 °C

Table 107 Room temperature

- ▶ Set the room temperature that should apply in the event of enabled external control.
- ▶ Value > 0 °C enables the function.

>>> **Block hot water production**

Factory setting	No
Alternative	No/Yes

Table 108 Blocking

>>> **Start collector circuit pump**

Factory setting	No
Alternative	No/Yes

Table 109 Start collector circuit pump

>>> **Alarm at low pressure in collector circuit**

Factory setting	No
Alternative	No/Yes

Table 110 Alarm at low pressure in collector circuit



This function requires the installation of a pressure switch in the collector circuit and its connection to the external input. In the event of incorrect pressure in the circuit, the external input closes, triggering a category A alarm (→ Chapter 17.7 ).

>> **External input circuit 2, 3...**

>>> **Invert input**

Factory setting	No
Alternative	No/Yes

Table 111 Invert input

- ▶ Select **Yes** if the input signal is to be reversed (i.e. activated with open contact).

>>> **Block heating at tripped underfloor temperature limiter (Circuit 2)**

Factory setting	No
Alternative	No/Yes

Table 112 Blocking

>>> **Block heating**

Factory setting	No
Alternative	No/Yes

Table 113 Blocking

>>> **Room temperature**

Factory setting	No (0.0 °C)
Lowest value	10.0 °C
Highest value	35.0 °C

Table 114 Room temperature

- ▶ Set the room temperature that should apply in the event of enabled external control.
- ▶ Value > 0 °C enables the function.

The highest temperature is used if temperature changes have been set for a certain circuit at several external inputs.

**16.7 Installer**

This section includes:

- **General**
- **Heat pump x capacity**
- **Connected I/O boards**
- **Compressor working area**
- **Generated energy**
- **Operating times and consumptions**
- **Temperatures**
- **Programmable outputs**
- **Inputs**
- **Outputs**
- **Circulation pumps**

> **General**

>> **Anti-seizure mode**

>>> **Day of the week**

Factory setting	Wednesday
Alternative	Monday-Sunday

Table 115 Anti-seizure day

>>> **Start time**

Factory setting	12:00
Alternative	0:00 - 23:00

Table 116 Anti-seizure start time

- ▶ Set date and time for anti-seizure operation of vital parts of the installation.

Anti-seizure mode ensures that vital components do not become clogged during periods when they are not used.

Anti-seizure mode operates differently in summer and in winter. This enables the duration of the anti-seizure operation to be reduced. Furthermore, during anti-seizure operation the entire system does not need to be switched off in winter.

**Anti-seizure mode in summer mode**



Anti-seizure mode starts only if there is no other type of demand. When there is a demand, the anti-seizure operation waits for one hour at the most for the demand to be satisfied. Otherwise, the anti-seizure operation has to wait until the next occasion.

Heat pump 1 runs first followed by heat pump 2, etc. 3-way valves and circulation pumps are run for 1 minute and mixing valves for the respective mixing valve's run time + 10s. A pause of 30s is made between components.

During anti-seizure mode, certain parts of the heating system become hot for a short period of time, which is completely normal.



The anti-seizure mode is not cancelled if hot water demand arises during the anti-seizure operation. The hot water temperature can thereby fall. A suitable time for anti-seizure operation is when the hot water consumption is low, e.g., at night.

**Anti-seizure mode in winter mode**

In winter mode, anti-seizure operation is executed on valves, mixers and pumps that normally do not operate in winter mode (refers to accessories such as cooling, pool and solar). Anti-seizure mode can occur during operation.

**>> Highest permitted flow temperature T1**

Factory setting	80,0 °C
Lowest value	10,0 °C
Highest value	100,0 °C

Table 117 Radiator

Factory setting	45,0 °C
Lowest value	10,0 °C
Highest value	45,0 °C

Table 118 Underfloor

**>> Operating mode**

- For a description of operating modes (→ Chapter 4.4 ).



The set operating mode is indicated with the symbol > before the alternative. Operating mode is selected directly the first time the heat pump is started. Operating mode can be changed here. The control unit allows only the alternative(s) that can be achieved with the installed equipment.

Selection of operating mode leads to automatic setting of certain values in the control unit.

**>> Groundwater**

Factory setting	No
Alternative	Yes/No

Table 119 G33

- Indicate if groundwater pump G33 exists or not. G33 is normally run simultaneously with collector circuit pump G3.

In the event of **Yes**:

**>>> Compressor start delay**

Factory setting	15s
Lowest value	0s
Highest value	600s

Table 120 Start delay compressor

- Indicate the delay that is required until the groundwater circuit circulates. The compressor should not start before this has taken place.

**>> Display light switch off delay**

Factory setting	5min
Lowest value	1min
Highest value	240min

Table 121 Display light switch off delay

- Set the delay before the display backlighting is automatically switched off after the last display activity (navigating, setting, alarm display etc.).

**>> Time for reset of access level**

Factory setting	20min
Lowest value	1min
Highest value	240min

Table 122 Reset of access level

- Set how much time it should take for the control unit to return automatically from installer level to customer level.

**> Heat pump x capacity**

Lowest value	6.0kW
	7.0kW
	9.0kW
	11.0kW
	14.0kW
Highest value	17.0kW

Table 123 Heat pump capacity

- The total capacity is selected under **Start-up**. If an incorrect value was selected, make changes in line with the heat pump type plate.

**> Connected I/O boards**

All boards and current version are displayed, if relevant.

**> Compressor working area**

This defines a number of functions that make the compressor stop temporarily or change operating mode to avoid more serious alarms.

**>> Outdoor stop function activated**

Factory setting	No
Alternative	Yes/No

Table 124 Outdoor temperature stop function

- Select **Yes** if the stop function should be active. The compressor stops when the outdoor temperature falls below the lowest permitted outdoor temperature for the compressor (-20 °C). When the outdoor temperature rises to a value that is higher than the lowest permitted temperature and this continues for 60 minutes (factory value), the stop function is deactivated and the compressor starts automatically if there is a demand.



The stop functions are always inactive at outdoor temperatures higher than 10 °C (factory value, not adjustable).

**> Generated energy**

This displays **Generated energy** in kWh divided into **Heating** and **Hot water**.

**> Operating times and consumptions**

The total operating time for the control unit, heat pump x and additional heat (active connection). It can also make short term measurements for compressor and additional heat.

> **Temperatures**

All connected/acknowledged sensors present values. The set point value is also given for some. The opportunity to correct the sensors is also given.

Open circuits/short circuits/faults in sensors are indicated with a dash in the  display and under **Temperatures**. Alarms are triggered and stored in alarm log and alarm history.

T2 Out	T2 display, correction, Attenuation
Temperatures heat pump x	T1 Start/stop limits compressor
	T6,T8,T9,T10,T11 display, correction
	T3 hot water start
	T8 hot water stop
Circuit x	T1 set point
	T1 display, correction
	T5 display, correction, Attenuation
	Room temperature set point value
Hot water	T3 display, correction
	Extra hot water stop temperature
	Hot water peak stop temperature

Table 125 Temperature display

**Deviation of T6 hot gas temperature**

Details regarding the hot gas temperature at T6 are also displayed if the actual value has deviated during the last 24 hours from the calculated ideal value. This enables the status of the refrigerant circuit to be assessed without special tools.

Deviations in excess of -10 °C can have the following causes:

- Filter E2x.V101 obstructed <sup>1)</sup>
- Compressor run time too short <sup>1)</sup>
- Incorrect temperature indication from an internal sensor <sup>1)</sup>
- Expansion valve works incorrectly (too much open) <sup>2)</sup>

Deviations in excess of +10 °C can have the following causes:

- Incorrect temperature indication from an internal sensor <sup>1)</sup>
- The expansion valve does not function as it should (too closed)<sup>2)</sup>
- Too little or too much refrigerant <sup>2)</sup>
- Contaminants, magnetite and/or limescale deposits in the condenser <sup>2)</sup>

<sup>1)</sup> Inspection and remedy possible by the installer.

<sup>2)</sup> Visit by an authorised refrigeration engineer with suitable tools for the inspection and remedy is required.

> **Programmable outputs**

Factory setting	E11.P2
Alternative	E41.G6/E11.P2

Table 126 Programmable outputs

> **Inputs**

The status of all inputs is displayed here. Pressure switches and motor cut-outs are shown for each heat pump. In addition, any alarms for shunted additional heat, status for external inputs and protective anode are shown.

Only connected inputs are displayed.

> **Outputs**

All components can be manually operated individually here to check function.

>> **Manual operation time**

Factory setting	0min
Lowest value	0min
Highest value	240min

Table 127 Manual operation time

- ▶ Set the number of minutes for manual operation. Different vital components can be put into operation/turned off separately. With 0min, status, e.g., **On** or **Off**, is displayed for each component.



Use the manual operation function on commissioning in order to check if the installed components work.

Manual operation is possible for the following components (only the ones that are installed are displayed):

- >> **G1 Heating circuit pump**
- >> **Heat pump x**
- >>> **Q21 Three-way valve (Heating/Hot water)**
- >>> **G2 Heat carrier pump**
- >>> **G2 Heat carrier pump speed**
- >>> **G3 Collector circuit pump**
- >>> **Compressor**
- >> **Hot water electric heater**
- >> **Hot water circulation pump**
- >> **Circuit 2, 3...**
- >>> **Circulation pump**
- >>> **Mixing valve signal**
- >>> **Mixing valve open**
- >>> **Mixing valve close**
- >> **Electric heater 1**
- >> **Electric heater 2**
- >> **Mixed additional heat**
- >>> **Mixed additional heat**
- >>> **Mixing valve signal**
- >>> **Mixing valve open**
- >>> **Mixing valve close**
- >> **Alarm buzzer**
- >> **General alarm**

## > Circulation pumps

### >> Heating circuit pump G1

#### >>> Operation alternative

Factory setting	Continuous
Alternative	Continuous/Automatic

Table 128 G1

- ▶ Select if circulation pump G1 should run continuously or in optimised operation. The setting applies to G1 of all circuits.

**Continuous** means that G1 is always in operation during the heating season.

**Automatic** means that the circulation pump runs in approx. 10 min, stands idle for 10 min, and so on, if it is in winter operation and there has not been any heating demand for 40 min. Automatic operation is cancelled when heating demand arises or winter operation is disabled.

G1 stands idle (apart from anti-seizure operation) if it is summer operation.

### >> Heat carrier pump G2

#### >>> Operation alternative

Factory setting	Continuous
Alternative	Continuous/Automatic

Table 129 G2

- ▶ Select if heat carrier pump G2 should run continuously or start automatically when the compressor starts.  
The setting applies to all heat pumps' G2. In automatic operation, G2 starts for heat pump 2 when compressor 2 starts.

### >>> Pump speed E2x

#### >>>> Fixed pump speed

Factory setting	Auto
Lowest value	0% (Auto)
Highest value	100%

Table 130 Fixed pump speed

- ▶ Set desired percentage to maintain a constant pump speed. Auto means the pump speed will be controlled by the control unit.

#### >>>> Temperature difference heat transfer fluid when heating

Factory setting	7K
Lowest value	3K
Highest value	15K

Table 131 Temperature difference heat transfer fluid when heating

- ▶ Specify the temperature difference which the heat pump will aim to achieve. This is done by regulating the pump speed.

#### >>>> Temperature difference heat transfer fluid when hot water

Factory setting	7K
Lowest value	3K
Highest value	15K

Table 132 Temperature difference heat transfer fluid when hot water

- ▶ Specify the temperature difference which the heat pump will aim to achieve. This is done by regulating the pump speed.

#### >>>> Pump speed at no demand

Factory setting	10%
Lowest value	1%
Highest value	100%

Table 133 Pump speed at no demand

- ▶ Set pump speed when there is no demand. A low speed is used to keep the system operating when there is no demand for heat.

## >>> Regulator settings

### >>>> P constant

Factory setting	3.0
Lowest value	0.1
Highest value	30.0

Table 134 P constant

### >>>> I constant

Factory setting	300.0
Lowest value	5.0
Highest value	600.0

Table 135 I constant

### >> Collector circuit pump G3

#### >>> Operation alternative

Factory setting	Automatic
Alternative	Continuous/Automatic

Table 136 G3

- ▶ Select if collector circuit pump G3 should run simultaneously with the compressor or continuously.

## 16.8 Additional heat

The additional heat works together with the heat pump to maintain the right heating in the circuits. The additional heat can be selected to work alone.



See manual for the multi-module for the mixed additional heat operating mode.

Under **Additional heat**, there are:

- **Additional heat general**
- **Electric additional heat**
- **Hot water electric heater**
- **Additional heat program**

### > Additional heat general

Under **Additional heat general** the functions that are common to electric additional heat and mixed additional heat are found.

#### >> Start delay

Factory setting	120min
Lowest value	0min
Highest value	240min

Table 137 Additional heat start delay

- ▶ Set what start delay should apply to the additional heat.  
When the need for additional heat arises, a timer with set time is started. When this time has passed the additional heat starts.

#### >> Additional heat only

Factory setting	No
Alternative	Yes/No

Table 138 Additional heat only

- ▶ Change to **Yes** if the additional heat should work alone.  
This can be suitable if the heat pump should provide heat before, e.g., the collector circuit is ready.

>> **Block additional heat**

Factory setting	No
Alternative	Yes/No

Table 139 Block additional heat

- ▶ Indicate if the additional heat should be blocked. In this case, the additional heat may not take part. The additional heat is, however, allowed to kick in in alarm mode and additional heat only mode if no other blocking function is enabled, e.g., type 1 energy supply cut-off.

>> **Maximum outdoor temperature for additional heat**

Factory setting	10 °C
Lowest value	-30 °C
Highest value	40 °C

Table 140 Maximum outdoor temperature for additional heat

- ▶ Set the desired temperature limit. If the outdoor temperature exceeds this value, the additional heat may not work.

> **Electric additional heat**

The control unit supports 1 additional heat unit.

The settings for connection capacity and regulator for the additional heat use are made under this menu.

> **Electric heater connection**

>> **Connected output**

- ▶ Shows the actual output of the input electric additional heat.

>>> **Output limitation in compressor mode**

Factory setting	6.0kW
Lowest value	0.0kW
Highest value	9.0kW

Table 141 Output limitation

- ▶ Set the output permitted during compressor operation.



A low value can result in hot water peak failure.

>>> **Output limitation when additional heat only**

Factory setting	6.0kW
Lowest value	0.0kW
Highest value	9.0kW

Table 142 Output limitation

- ▶ Set the output permitted when the compressor is not in operation.

>>> **Output limitation in hot water mode**

Factory setting	6.0kW
Lowest value	0.0kW
Highest value	9.0kW

Table 143 Output limitation

- ▶ Set the output permitted during hot water production.

>> **Regulator settings**

>>> **P constant**

Factory setting	4.0
Lowest value	0.1
Highest value	30.0

Table 144 P constant

>>> **I constant**

Factory setting	300.0
Lowest value	5.0
Highest value	600.0

Table 145 I constant

>>> **D constant**

Factory setting	0.0
Lowest value	0.0
Highest value	10.0

Table 146 D constant

>>> **Minimum PID signal**

Factory setting	0%
Lowest value	0%
Highest value	100%

Table 147 Minimum PID signal

>>> **Maximum PID signal**

Factory setting	100%
Lowest value	0%
Highest value	100%

Table 148 Maximum PID signal

> **Hot water electric heater**

Under **Additional heat**, there are also settings for additional electric heat in hot water heaters.

>> **Acknowledge hot water additional heat**

Factory setting	No
Alternative	Yes/No

Table 149 Additional electric heat, hot water



Operating modes **Mixed additional heat**, **Extra hot water** and **Hot water peak** requires additional heat in the hot water heater

### > Additional heat program

This function can be used to set the times between which additional heat mode is blocked.

#### >> Activate program

Factory setting	No
Alternative	No/Yes

Table 150 Activate additional heat program

#### >> View/edit active program

Only displayed if a program has been selected.

#### >> Outdoor temperature limit for deactivation of time control

Only displayed if a program has been selected.

Factory setting	-26 °C (Off)
Lowest value	-26 °C
Highest value	20 °C

Table 151 Outdoor temperature limit time control

- ▶ Set a suitable temperature for deactivation of time control. -26 °C = function **Off**.

If T2 is over set **Outdoor temperature limit for deactivation of time control** for 15 minutes, or if **Outdoor temperature limit for deactivation of time control** is set to **Off**, the additional heat will be blocked by time control as long as **Additional heat program** is activated.

If T2 is under set **Outdoor temperature limit for deactivation of time control** or if **Additional heat program** is deactivated the additional heat will not be blocked by time control.

## 16.9 Safety functions

- **Setting collector circuit in T10**
- **Setting collector circuit out T11**

The settings for collector circuit in/out are:

#### > Setting collector circuit in T10 / Setting collector circuit out T11

#### >> Lowest permitted temperature E21.T10 / Lowest permitted temperature E21.T11

Factory setting	-6,0 °C (T10) -8,0 °C (T11) 4,0 °C Groundwater (T10) 2,0 °C Groundwater (T11)
Lowest value	-10,0 °C
Highest value	20,0 °C

Table 152 Lowest temperature, collector circuit

#### >> Hysteresis alarm reset

Factory setting	1.0K
Lowest value	1.0K
Highest value	10.0K

Table 153 Hysteresis

#### >> Number of warnings before alarm

Factory setting	1
Lowest value	1
Highest value	4

Table 154 Number of warnings before alarm

The number of warnings is calculated during a time period of 180 min.

## 16.10 General

Among other things, settings for date and time are available here.

### > Room sensor settings

#### >> Show outdoor temperature in room sensor

Factory setting	No
Alternative	Yes/No

Table 155 Show outdoor temperature in the room sensor

#### > Set date

Factory setting	
Format	yyyy-mm-dd

Table 156 Date

#### > Set time

Factory setting	
Format	hh:mm:ss

Table 157 Time

- ▶ Check and change, if necessary, date and time. These are used by the control unit to manage the different clock settings, e.g., holiday and room temperature program.

#### > Summer/winter time

Factory setting	Automatic
Alternative	Manual/Automatic

Table 158 Summer/winter time.

- ▶ Select if there should be automatic change over between summer and winter time or not (dates according to EU standard).

#### > Display contrast

Factory setting	70%
Lowest value	20%
Highest value	100%

Table 159 Brightness

- ▶ If necessary, change the background light of the control panel.

#### > Language

- ▶ Change language, if desired.



Language change can also be brought about by holding down the -button in the standard display for at least 5 s.

#### > Country

- ▶ Select country.  
Here, a different country can be selected than was chosen as part of the pre-configuration (start-up).

### 16.11 Alarms

The different alarms that can occur are described in (→Chapter 17 ).

Under **Alarms** there is:

- **Information log**
- **Delete information log**
- **Alarm log**
- **Delete alarm log**
- **Alarm history**
- **Alarm indication**

#### > Information log

The information log shows information from the heat pump. The information log symbol is displayed in the control panel start-up position when there is active information.

#### > Delete information log

The information log is deleted here.

#### > Alarm log

The alarm log shows the alarms and warnings that have occurred. Alarm category (→ Chapter 17.7 ) is displayed in the top left corner of the display and if the alarm is active, the alarm symbol is displayed both in the alarm log and the initial menu of the control panel.

#### > Delete alarm log

The alarm log is deleted here

#### > Alarm history

Alarm history shows extensive information about the 20 most recent alarms that have occurred. For example actual and set point values of the temperature sensor and heat pump status at the time of the alarm. Limited information is displayed for older alarms.

#### > Alarm indication

Settings for alarm buzzer and status lamp are made here.

#### >> Alarm buzzer signal

##### >>> Interval

Factory setting	2s
Lowest value	2s
Highest value	3600s (60min)

Table 160 Interval

- ▶ Set the length of the alarm interval.  
The alarm buzzer sounds for one second and is silent during the rest of the interval. The setting applies to all alarm buzzers.

##### >>> Blocking time

Factory setting	Off
Start time	0:00 - 23:45
Stop time	0:00 - 23:45

Table 161 Blocking time

- ▶ Indicate the times between which the alarm buzzer may not give out a sound.  
All alarm buzzers are silent during a set interval.

#### >> Alarm indication control unit

##### >>> Block alarm buzzer

Factory setting	No
Alternative	No/Yes

Table 162 Block alarm buzzer

The setting applies only to the control unit's alarm buzzer.

#### >> Alarm indication room sensor

##### >>> Block alarm indicator lamp

Factory setting	No
Alternative	Yes/No

Table 163 Block indicator lamp

- ▶ Set if the indicator lamp should be off or not.

The setting applies to all room sensors.

#### >> General alarm level

##### >>> Alarms and warnings

Factory setting	No
Alternative	No/Yes

Table 164 Alarms and warnings

**No** means that alarms produce a signal on the general alarm output. **Yes** means that alarms as well as warnings produce a signal on the general alarm output.

### 16.12 Access level

Access level is **Customer** as standard: This level gives you access to all functions that the user requires. The installer also has access to the additional functions required at installation.

### 16.13 Return to factory settings

- ▶ Select **Return to factory settings** and **Yes** to reset all settings to the factory settings. Settings made by the customer are not affected.

Factory setting	No
Alternative	Yes/No

Table 165 Return to factory settings



## 17 Alarms

### 17.1 Alarms

This section includes:

- **Information log** (→ Chapter 16.11 )
- **Delete information log** (→ Chapter 16.11 )
- **Alarm log** (→ Chapter 16.11 )
- **Delete alarm log** (→ Chapter 16.11 )
- **Alarm history** (→ Chapter 16.11 ).

### 17.2 Control unit and room sensor alarm lamp

The status lamp on the control unit is used to show ON/OFF status for the heat pump but also to show possible alarms. The status lamp is therefore also called alarm lamp.

The room sensor alarm lamp can be blocked.

Behaviour	Function
<i>The lamp lights green continuously.</i>	The heat pump is running.
<i>The lamp flashes red.</i>	There is an alarm which has not been acknowledged.
<i>The lamp lights red continuously.</i>	The alarm has been acknowledged but the alarm cause remains.
<i>The lamp flashes green slowly.</i>	The heat pump is in stand-by mode <sup>1)</sup> .

Table 166 Alarm lamp control unit

1) Stand-by means that the heat pump is running but no heating or hot water demand exists.

The room sensor display is used to indicate alarms for some alarm categories (→ 17.7 ). The display window slowly flashes red until the alarm has been acknowledged in the heat pump control unit, or been automatically reset.

The room sensor alarm display function is referred to as alarm lamp in this chapter.

The room sensor alarm lamp can be blocked.

### 17.3 Alarm display

When an alarm/warning occurs, the display shows information about what has happened. At the same time, information is saved in the alarm log and alarm history.

### 17.4 Alarm buzzer at alarm

At an alarm the alarm buzzer on the heat pump sounds for one second per alarm buzzer interval set. At certain times of the day the alarm buzzer can be blocked or blocked altogether.

In the event of a warning alarm, the alarm buzzer does not sound.

### 17.5 Acknowledgement of alarms

Acknowledgement means that you have to press  to make the alarm window disappear. What happens after acknowledgement is described in the respective alarm description.

In most cases, warnings do not have to be acknowledged. The alarm window disappears by itself once the warning cause has disappeared. It is, however, possible to acknowledge the warning.

### 17.6 Alarm timer, alarm mode

In the event of an alarm that stops the compressor the control unit starts a timer at 1h. If the fault does not recur additional heat may start when the timer has counted down.

### 17.7 Alarm categories

The alarms are divided into different categories depending on the type and seriousness of the fault. Alarm category is displayed in the alarm window, alarm log and alarm history.

**Categories A-H are alarms, categories I-J are warnings/information, categories K-M are warnings, category Z is information.**

Meaning	A	B	C	D	E	F	G	h	In	J	K	L	M	Z
Stops the compressor	X	X	X	X	X				X	X				
Stops additional heat						X	X				X			
Alarm lamp, alarm buzzer is activated	X	X	X	X	X	X	X	X						
Alarm delay	5s	3s	15 min	1 min	5s	1s	1s	1s	5s	5s	2s	5s	0s	0s
Requires acknowledgement to restart	X	X	X	X		X								
Can be restarted before acknowledgement					X		X	X	X	X	X		X	
Menu display must be acknowledged	X	X	X	X	X	X	X	X				X	X	
Placed in the information log									X	X				X

Table 167 Alarm categories

- [In] Temporary stop of compressor. The information may recur a number of times during a certain time period; if there are more during the period, a category A alarm is sounded.
- [J] Temporary stop of compressor. The information may recur a number of times during a certain time period; if there are more during the period, a category A alarm is sounded.
- [M] Used for board connection problems.

### 17.8 Alarm window

When an alarm/warning occurs, the display shows information about what has happened. At the same time, information is saved in the alarm log and alarm history.

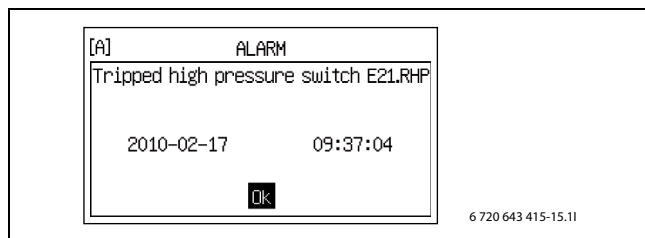

Fig. 52 Example

## 17.9 Alarm functions

The alarm text is indicated in the heading.

### 17.9.1 High hot gas temperature E2x.T6

**Function:** Compressor stops. Activated when the temperature on sensor T6 exceeds the applicable maximum hot gas temperature.

**Alarm timer starts:** Yes.

**Reset condition:** The hot gas temperature drops 5K below the alarm limit.

**Category:** A.

**Alarm lamp/buzzer:** Yes.

**Restart:** Acknowledgement is required.

### 17.9.2 Tripped low pressure switch E2x.RLP

**Function:** The compressor is stopped because of too low pressure in the refrigerant circuit. Activated on open contact on the low pressure switch. The alarm is delayed with 150s after compressor start or alternation between hot water and heating production.

**Alarm timer starts:** Yes.

**Reset condition:** Closed signal over the pressure switch.

**Category:** A.

**Alarm lamp/buzzer:** Yes.

**Restart:** Acknowledgement is required.

### 17.9.3 Tripped high pressure switch E2x.RHP

**Function:** The compressor is stopped because of too high pressure in the refrigerant circuit. Activated on open contact on the high pressure switch.

**Alarm timer starts:** Yes.

**Reset condition:** Closed signal over the pressure switch.

**Category:** A.

**Alarm lamp/buzzer:** Yes.

**Restart:** Acknowledgement is required.

### 17.9.4 Low pressure collector circuit

**Function:** If **Alarm at low pressure in collector circuit** is selected and the external input closes, this alarm is triggered. The compressor stops (→ Chapter 16.6 ).

**Alarm timer starts:** Yes.

**Reset condition:** The pressure exceeds the set level. The setting is made on the pressure switch.

**Category:** A.

**Alarm lamp/buzzer:** Yes.

**Restart:** Acknowledgement is required.

### 17.9.5 Low temperature collector circuit in E2x.T10

**Function:** Warning/alarm is given if the temperature of the collector circuit in is too low. First, a warning is given. If the warning appears several times during a certain time period, the warning transforms into a category A alarm.

For settings of T10: (→Chapter 16.9 ).

**Alarm timer starts:** Yes.

**Reset condition:** T10 exceeds the lowest permitted temperature T10 plus hysteresis.

**Category:** J which goes over into A.

**Alarm lamp/buzzer:** Yes.

**Restart:** Acknowledgement is required in category A.

### 17.9.6 Low temperature collector circuit out E2x.T11

**Function:** Warning/alarm is given if the temperature of the collector circuit out is too low. First, a warning is given. If the warning appears several times during a certain time period, the warning transforms into a category A alarm.

For settings of T11: (→Chapter 16.9 ).

**Alarm timer starts:** Yes.

**Reset condition:** T11 exceeds the lowest permitted temperature T11 plus hysteresis.

**Category:** J which goes over into A.

**Alarm lamp/buzzer:** Yes.

**Restart:** Acknowledgement is required in category A.

### 17.9.7 Too high boot count I/O board BAS x

**Function:** Compressor stops. Is activated if the controller has executed more than three new starts after the alarm **Check CANbus cable connection**, (→ Chapter 17.9.40 ).

**Alarm timer starts:** Yes.

**Reset condition:** The CANbus communication with the controller has been restored.

**Category:** A.

**Alarm lamp/buzzer:** Yes.

**Restart:** Acknowledgement is required.

► Contact the dealer if the alarm remains after acknowledgement.

### 17.9.8 Motor cut-out 1 E2x.F11, Compressor

**Function:** Activated when the compressor's motor cut-out has tripped because of high current or lost current phase resulting in undue strain on the compressor.

Alarms may also be due to alarms from the soft starter (→ Chapter 10.2 ).

**Alarm timer starts:** Yes.

**Reset condition:** Motor cut-out reset.

**Category:** B.

**Alarm lamp/buzzer:** Yes.

**Restart:** Reset the motor cut-out / correct the softstarter alarm.

### 17.9.9 Failure on sensor E2x.T6 hot gas

**Function:** The compressor stops because the hot gas cut-out cannot be guaranteed. Activated when the sensor's value indicates a temperature lower than -50 °C.

**Alarm timer starts:** Yes.

**Reset condition:** The value of the sensor indicates > -50 °C.

**Category:** E.

**Alarm lamp/buzzer:** Yes.

**Restart:** Automatic once the alarm cause has disappeared.

### 17.9.10 Short circuit on sensor E2x.T6 hot gas

**Function:** The compressor stops because the hot gas cut-out cannot be guaranteed. Activated when the sensor's resistance value indicates a temperature higher than 150 °C.

**Alarm timer starts:** Yes.

**Reset condition:** The value of the sensor indicates < 150 °C.

**Category:** E.

**Alarm lamp/buzzer:** Yes.

**Restart:** Automatic once the alarm cause has disappeared.

### 17.9.11 High flow temperature E1x.T1

**Function:** The compressor stops because the flow temperature is too high for the heating circuit. Activated when the sensor shows a value which is 5K higher than the highest set point value for the circuit. The factory setting for the highest set point value is 60 °C for radiator type of circuit and 35 °C for underfloor type of circuit

After hot water production, the alarm is delayed with 4 min.

**Alarm timer starts:** Yes.

**Reset condition:** The sensor's value falls below the temperature for beginning of the heating demand.

**Category:** E.

**Alarm lamp/buzzer:** Yes.

**Restart:** Automatic once the alarm cause has disappeared.

### 17.9.12 Faulty electric heater E21.E2

**Function:** The electric heater is turned off. Activated by tripped overheat protection on the electric additional heat, high flow temperature or too high temperature in electric additional heat. The automatic trip fuse to the electric additional heat may have been tripped due to, for example, a short circuit.

**Reset condition:** Overheat protection reset.

**Category:** F.

**Alarm lamp/buzzer:** Yes.

**Restart:** Acknowledgement is required.

### 17.9.13 Overheat protection tripped hot water electric heater

**Function:** The electric heater is turned off. If alarm output from the electric heater has been connected to the multi module, the alarm is given when an error occurs.

**Reset condition:** The error in the electric heater has been overcome and no alarm signal.

**Category:** F.

**Alarm lamp/buzzer:** Yes.

**Restart:** Acknowledgement is required.

### 17.9.14 Faulty protective anode E41.F31

**Function:** The alarm is activated when the anode in the hot water heater is broken or does not work. Presupposes that **Yes** is indicated in **Protective anode installed**.

**Reset condition:** The anode should be taken care of so as to prevent corrosion in the hot water heater.

**Category:** H.

**Alarm lamp/buzzer:** Yes.

**Restart:** Acknowledgement is required.

### 17.9.15 Failure on sensor E11.T1 flow

**Function:** The alarm is activated when the sensor's value indicates a temperature lower than 0 °C. The flow temperature T1 becomes identical to T8. If there are several heat pumps installed, T1 = T8 for the heat pump that does not produce hot water and has the highest value on T8. Additional heat mixing valve shut.

**Reset condition:** The value of the sensor indicates >0 °C.

**Category:** H.

**Alarm lamp/buzzer:** Yes.

**Restart:** Automatic once the alarm cause has disappeared.

### 17.9.16 Short circuit on sensor E11.T1 flow

**Function:** The alarm is activated when the sensor's value indicates a temperature higher than 110 °C. The flow temperature T1 becomes identical to T8. If there are several heat pumps installed, T1 = T8 for the heat pump that does not produce hot water and has the highest value on T8. Additional heat mixing valve shut.

**Reset condition:** The value of the sensor indicates < 110 °C.

**Category:** H.

**Alarm lamp/buzzer:** Yes.

**Restart:** Automatic once the alarm cause has disappeared.

### 17.9.17 Failure on sensor E12.T1, E13.T1... flow

**Function:** The alarm is activated when the sensor's value indicates a temperature lower than 0 °C. The mixing valve for the circuit is closed completely.

**Reset condition:** The value of the sensor indicates >0 °C.

**Category:** H.

**Alarm lamp/buzzer:** Yes.

**Restart:** Automatic once the alarm cause has disappeared.

### 17.9.18 Short circuit on sensor E12.T1, E13.T1... flow

**Function:** The alarm is activated when the sensor's value indicates a temperature higher than 110 °C. The mixing valve for the circuit is closed completely.

**Reset condition:** The value of the sensor indicates < 110 °C.

**Category:** H.

**Alarm lamp/buzzer:** Yes.

**Restart:** Automatic once the alarm cause has disappeared.

### 17.9.19 Failure on sensor T2 outdoor

**Function:** The alarm is activated when the sensor's value indicates a temperature lower than -50 °C. In the event of a failure on T2, the outdoor temperature is set to 0 °C.

**Reset condition:** The value of the sensor indicates > -50 °C.

**Category:** H.

**Alarm lamp/buzzer:** Yes.

**Restart:** Automatic once the alarm cause has disappeared.

### 17.9.20 Short circuit on sensor T2 outdoor

**Function:** The alarm is activated when the sensor's value indicates a temperature higher than +70 °C. In the event of a short circuit on T2, the outdoor temperature is set to 0 °C.

**Reset condition:** The value of the sensor indicates < 70 °C.

**Category:** H.

**Alarm lamp/buzzer:** Yes.

**Restart:** Automatic once the alarm cause has disappeared.

### 17.9.21 Failure on sensor T3 hot water

**Function:** The alarm is activated when the sensor's value indicates a temperature lower than 0 °C. The hot water production is terminated.

**Reset condition:** The value of the sensor indicates >0 °C.

**Category:** H.

**Alarm lamp/buzzer:** Yes.

**Restart:** Automatic once the alarm cause has disappeared.

**17.9.22 Short circuit on sensor T3 hot water**

**Function:** The alarm is activated when the sensor's value indicates a temperature higher than +110 °C. The hot water production is terminated.

**Reset condition:** The value of the sensor indicates < 110 °C.

**Category:** H.

**Alarm lamp/buzzer:** Yes.

**Restart:** Automatic once the alarm cause has disappeared.

**17.9.23 Failure on sensor E1x.TT.T5 room**

**Function:** The alarm is activated when the sensor's value indicates a temperature lower than -1 °C. In the event of a failure on sensor T5, the room temperature influence is set to 0.

**Reset condition:** The value of the sensor indicates > -1 °C.

**Category:** H.

**Alarm lamp/buzzer:** Yes.

**Restart:** Automatic once the alarm cause has disappeared.

**17.9.24 Short circuit on sensor E1x.TT.T5 room**

**Function:** The alarm is activated when the sensor's value indicates a temperature higher than +70 °C. In the event of a short circuit on sensor T5, the room temperature influence is set to 0.

**Reset condition:** The value of the sensor indicates < 70 °C.

**Category:** H.

**Alarm lamp/buzzer:** Yes.

**Restart:** Automatic once the alarm cause has disappeared.

**17.9.25 Failure on sensor E2x.T8 heat transfer fluid out**

**Function:** Activated when the sensor's value indicates a temperature lower than 0 °C. To be able to make hot water, T8 is set at a temperature calculated according to the following formula:  $T8 = T9 + Compressor \times 7K + 0.07K \times current\ output\ in\ operation$ .

The active compressor provides  $Compressor = 1$  and *current output in operation* means additional heat in %. Compressor operation and 50% additional heat then give  $T8 = T9 + 10.5K$ . Compressor off ( $Compressor = 0$ ) and no additional heat (0%) give  $T8 = T9$ .

**Reset condition:** The value of the sensor indicates >0 °C.

**Category:** H.

**Alarm lamp/buzzer:** Yes.

**Restart:** Automatic once the alarm cause has disappeared.

**17.9.26 Short circuit on sensor E2x.T8 heat transfer fluid out**

**Function:** Activated when the sensor's value indicates a temperature higher than 110 °C. T8 is calculated according to the same formula as in the event of a failure → Chapter 17.9.25 ).

**Reset condition:** The value of the sensor indicates < 110 °C.

**Category:** H.

**Alarm lamp/buzzer:** Yes.

**Restart:** Automatic once the alarm cause has disappeared.

**17.9.27 Failure on sensor E2x.T9 heat transfer fluid in**

**Function:** Activated when the sensor's value indicates a temperature lower than 0 °C. T9 is calculated according to the following formula:  $T9 = T8 - Compressor \times 7K + 0.07K \times current\ output\ in\ operation$ .

**Reset condition:** The value of the sensor indicates >0 °C.

**Category:** H.

**Alarm lamp/buzzer:** Yes.

**Restart:** Automatic once the alarm cause has disappeared.

**17.9.28 Short circuit on sensor E2x.T9 heat transfer fluid in**

**Function:** Activated when the sensor's value indicates a temperature higher than 110 °C. T9 is calculated according to the following formula:  $T9 = T8 - Compressor \times 7K + 0.07K \times current\ output\ in\ operation$ .

**Reset condition:** The value of the sensor indicates < 110 °C.

**Category:** H.

**Alarm lamp/buzzer:** Yes.

**Restart:** Automatic once the alarm cause has disappeared.

**17.9.29 Failure on sensor E2x.T10**

**Function:** Activated when the sensor's resistance value indicates a temperature lower than -20 °C. In the event of a failure, T10 is set at a temperature calculated according to the following formula:  $T10 = T11 + Compressor \times 3K$ .

**Reset condition:** The value of the sensor indicates > -20 °C.

**Category:** H.

**Alarm lamp/buzzer:** Yes.

**Restart:** Automatic once the alarm cause has disappeared.

**17.9.30 Short circuit on sensor E2x.T10**

**Function:** Activated when the sensor's value indicates a temperature higher than 70 °C. In the event of a short circuit, T10 is set to an estimated temperature using this formula:  $T10 = T11 + Compressor \times 3K$ .

**Reset requirement:** The value of the sensor indicates >70 °C.

**Category:** H.

**Alarm lamp/buzzer:** Yes.

**Restart:** Automatic once the alarm cause has disappeared.

**17.9.31 Failure on sensor E2x.T11**

**Function:** Activated when the sensor's value indicates a temperature lower than -50 °C. In the event of a failure, T11 is set at a temperature calculated according to the following formula:  $T11 = T10 - Compressor \times 3K$ .

**Reset condition:** The value of the sensor indicates > -50 °C.

**Category:** H.

**Alarm lamp/buzzer:** Yes.

**Restart:** Automatic once the alarm cause has disappeared.

### 17.9.32 Short circuit on sensor E2x.T11

**Function:** Activated when the sensor's value indicates a temperature higher than 70 °C. In the event of a short circuit, T11 is set to an estimated temperature using formula:  
 $T11 = T10 - Compressor \times 3K$ .

**Reset requirement:** The value of the sensor indicates >70 °C.

**Category:** H.

**Alarm lamp/buzzer:** Yes.

**Restart:** Automatic once the alarm cause has disappeared.

### 17.9.33 Additional heat is now working at its highest temperature

**Function:** The electric additional heat begins to be stepped down. The warning is activated in additional heat mode if the sensor T8 approaches the highest temperature permitted for T8. The warning is blocked during hot water peaks or extra hot water.

**Reset condition:** The warning is deactivated when the sensor temperature falls sufficiently.

**Category:** K.

**Alarm lamp/buzzer:** No.

**Restart:** Automatic once the alarm cause has disappeared.

### 17.9.34 Electric additional heat shut down due to high temperature E2x.T8

**Function:** The electric heater is turned off. The warning is activated in additional heat mode if the sensor T8 exceeds 80 °C.

**Reset condition:** The warning is deactivated when T8 falls below 76 °C.

**Category:** K.

**Alarm lamp/buzzer:** No.

**Restart:** Automatic once the alarm cause has disappeared.

### 17.9.35 High temperature difference heat transfer fluid E2x

**Function:** The warning is activated when the difference between sensor E2x.T8 and E2x.T9 exceeds 13K. 10 min after compressor start and change of production mode, the temperature difference is measured and if it is too big, the warning is given after a delay of 3 min. The warning is not given when the compressor is inactive or when additional heat is allowed.

**Reset condition:** The warning does not shut down any function but is registered in the alarm log.

**Category:** L.

**Alarm lamp/buzzer:** No.

**Restart:** Deactivated on acknowledgement of the warning display.

### 17.9.36 High temperature difference collector circuit E2x

**Function:** The warning is activated when the difference between sensor E2x.T10 and E2x.T11 exceeds 6K. 30 min after compressor start and change of production mode, the temperature difference is measured and if it is too big, the warning is given after a delay of 15 min. The warning is not given when the compressor is inactive.

**Reset condition:** The warning does not shut down any function but is registered in the alarm log.

**Category:** L.

**Alarm lamp/buzzer:** No.

**Restart:** Deactivated on acknowledgement of the warning display.

### 17.9.37 Sreed drying set point value for heating not reached

**Function:** Activated when the set point value for a drying step has not been reached.

**Reset condition:** The warning is deactivated on acknowledgement of the warning display.

**Category:** L.

**Alarm lamp/buzzer:** No.

**Restart:** The warning does not shut down anything, the drying program continues with the following step.

### 17.9.38 The heat pump is now working in anti-freeze mode

**Function:** Activated when the flow temperature of a circuit falls below 8 °C and the 10-min timer has counted down.

**Reset condition:** The circuit's flow temperature exceeds 25 °C.

**Category:** L.

**Alarm lamp/buzzer:** No.

**Restart:** Automatic once the alarm cause has disappeared.

### 17.9.39 Check connection to I/O board x

**Function:** Depends on the board.

**Reset condition:** Communication with the board is re-established.

**Category:** M.

**Alarm lamp/buzzer:** No.

**Restart:** Acknowledgement is required.

### 17.9.40 Check CANbus cable connection

**Function:** Communication with the controller has been interrupted. The controller executes a new start if the alarm is still active after two hours. If more than three new starts have been carried out within one hour, the alarm **Too high boot count I/O board BAS x** (category A), → Chapter 17.9.7 .

**Category:** M.

**Alarm lamp/buzzer:** No.

**Restart:** Acknowledgement is required.

► Contact the dealer if the warning recurs often.

### 17.9.41 Check connection to room sensor E1x.TT

**Function:** Activated when communication with the room sensor is terminated.

**Reset condition:** Communication with the board is re-established.

**Category:** M.

**Alarm lamp/buzzer:** Yes/No.

**Restart:** Acknowledgement is required.

### 17.10 Alarm log

The alarm log shows the alarms, warnings and other information that has come up. Alarm category (→ Chapter 17.7 ) is displayed in the top left corner of the display and if the alarm is active, the alarm symbol is displayed both in the alarm log and the initial menu of the control panel.

### 17.11 Alarm history

The alarm history saves complete information about the latest 20 alarms/warnings. Older alarms are displayed with limited information. What happened latest is listed as number 1.

Press  and turn the dial to see all information about the alarm. Turn the dial to see more alarms.

The information shows the current values immediately after the appearance of the alarm but before action/cancellation.

Information	Comment/Value
Alarm category	Letter (→Table 167). Displayed in the top left corner of the display.
Alarm text	Displayed at the top of the display. Full component name is most often indicated.
Start date, Start time	Indicates when the alarm occurred
Stop date, Stop time	Indicates when the alarm was acknowledged/cancelled
=====	
Heat pump x	On (/%) / Off
Additional heat	%/Off/Blocked
=====	
T1 Flow line	Current value
T1 Flow line set point value	Current set point value
T2 Out	Current outdoor temperature
Hot water	Calculated hot water temperature
Hot water set point value	
T5 Room	Current value if room sensor exists
Room	Current value if room sensor does not exist/is used
G1 Heat carrier pump	Off/On
=====	
Heat pump E2x	
E2x.T6 Hot gas	Current value
E2x.T8 Heating medium out.	Current value
E2x.T9 Heating medium in	Current value
E2x.T10 Collector circuit in	Current value
E2x.T11 E2x.T10 Collector circuit out	Current value
E2x.RLP Low pressure switch	OK/Error
E2x.RHP High pressure switch	OK/Error
E2x.G2 Heat carrier pump	Off/On
E2x.G3 Collector circuit pump	Off/On
E2x.Q21 3-way valve	Off/On

Table 168 Information in Alarm history

### 17.12 Information log

The information log shows information from the heat pump.

#### 17.12.1 High flow temperature E2x.T8

**Function:** Compressor stops. Activated when the temperature on sensor T8 exceeds the maximum permitted temperature for T8.

**Reset condition:** Restarts when E2x.T9 falls below the saved temperature with hysteresis on 3K (not adjustable).

**Category:** I.

#### 17.12.2 Temporary heat pump stop E21.RLP

**Function:** Activated when the pressure in the refrigerant circuit of the heat pump becomes too low. If the information appears several times during a certain time period, the information transforms into a category A alarm (→ Chapter 17.9.2 ).

**Reset condition:** The pressure goes back to the permitted level.

**Category:** I.

#### 17.12.3 Temporary heat pump stop E21.RHP

**Function:** Activated when the pressure in the refrigerant circuit becomes too high. If the information appears several times during a certain time period, the information transforms into a category A alarm (→ Chapter 17.9.3 ).

**Reset condition:** The pressure goes back to the permitted level.

**Category:** I.

#### 17.12.4 Low temperature collector circuit in E2x.T10

**Function:** The information is given if the temperature of the collector circuit in is too low. First, a information is given. If the information appears several times during a certain time period, the informations transforms into a category A alarm.  
For settings of T10: (→Chapter 16.9 ).

**Alarm timer starts:** Yes.

**Reset condition:** T10 exceeds the lowest permitted temperature T10 plus hysteresis.

**Category:** J which goes over into A.

#### 17.12.5 Low temperature collector circuit out E2x.T11

**Function:** The information is given if the temperature of the collector circuit out is too low. First, a information is given. If the information appears several times during a certain time period, the warning transforms into a category A alarm.  
For settings of T11: (→Chapter 16.9 ).

**Alarm timer starts:** Yes.

**Reset condition:** T11 exceeds the lowest permitted temperature T11 plus hysteresis.

**Category:** J which goes over into A.

#### 17.12.6 Hot water peak failure, new try within 24 hours

**Function:** The hot water has not come up at the right temperature. The hot water peak is repeated at the same time on the next day.

**Reset condition:** The correct hot water peak temperature is reached.

**Category:** Z.

#### 17.12.7 Temporary heat pump stop due to working area limits

**Function:** The information is displayed only if *Hot gas stop function activated* has been set to Yes. The compressor stops until the hot gas temperature falls below the set limit.

**Reset condition:** The hot gas temperature is within the range of the compressor.

**Category:** Z.

#### 17.12.8 Temporary hot water stop due to working area limits

**Function:** The information is displayed only if *Hot gas stop function activated* has been set to Yes. Ongoing hot water operation is aborted and replaced with heating operation.

**Reset condition:** The hot gas temperature is within the range of the compressor.

**Category:** Z.

#### 17.12.9 Additional heat is now working at its highest temperature

**Function:** The additional heat begins to be stepped down. The information is activated in additional heat mode if the outgoing temperature (T1 or T8) approaches the set maximum value. The information is blocked during hot water peaks or extra hot water.

**Reset condition:** The information is deactivated when the temperature falls.

**Category:** Z.

#### 17.12.10 Temporary hot water stop E2x

**Function:** Ongoing DHW mode is temporarily interrupted; the system changes over to heating mode.

**Reset condition:** DHW temperature drops a few degrees.

**Category:** Z.



## 18 Factory settings

### 18.1 Return to factory settings

The function exists on both customer and installer level. All settings available to the customer are restored on customer level. All settings on installer level are restored when the function is used on installer level. Customer level settings are not affected.

### 18.2 Factory values

Access level 0 = Customer

Access level 1 = Installer

Room temperature			F value	Access level	
Circuit 1 Heating	Type of heating system		Underfloor	1	
	Highest permitted flow temperature T1		80/45 °C	1	
	Lowest permitted flow temperature T1		10 °C	1	
	Heat curve			0	
	Heat curve hysteresis heat pump x	Maximum		25.0K	1
		Minimum		4.0K	1
		Time factor		20.0	1
	Room sensor	Room temperature influence		3,0	1
		Acknowledge room sensor		(Auto)	1
	Room temperature program	Active program		HP optimized	0
		View/edit active program			0
		Room temperature normal		20,0 °C	0
		Temperature increase/decrease (no room sensor)		=	0
		Setting temp. increase/decrease (no room sensor)			1
		> Limit value for left or right end point		0,0 °C	1
		> Change when much colder/warmer		8%	1
		> Change when colder/warmer		3%	1
Room temperature influence (no room sensor)			3,0	0	
Room temperature exception			17,0 °C	0	
Copy to all heating circuits		No	0		
Circuit 2, 3...	Mixing valve mode		Off	1	
	Type of heating system		Underfloor	1	
	Highest permitted flow temperature T1	Radiator/Underfloor	80/45 °C	1	
	Lowest permitted flow temperature T1		10 °C	1	
	Heat curve			0	
	Room sensor	As Circuit 1 Heating		0, 1	
	Room temperature program	As Circuit 1 Heating minus Copy to all heating circuits		0, 1	
	Regulator settings	P constant		1,0	1
		I constant		300	1
		D constant		0.0	1
		Minimum PID signal		0%	1
Maximum PID signal			100%	1	
Mixing valve running time			300s	1	
Mixing valve fully closed			2.0K	1	
Mixing valve start closing		2.0K	1		
General	Summer/winter operation	Winter operation	Automatic	0	
		Outdoor temperature limit for change over	18 °C	0	
		Delay before change over to winter operation	4h	1	
		Delay before change over to summer operation	4h	1	
		Direct start limit for winter operation	13 °C	1	
	Maximum operating time for heating at hot water demand		20min	1	
	Minimum outdoor temperature		-35 °C	1	

Table 169 Factory settings Room temperature

## Factory settings

Hot water		F value	Access level
Acknowledge hot water sensor T3		(Auto)	1
Extra hot water	Extra hot water duration	0h	0
	Extra hot water stop temperature	65 °C	0
Hot water peak	Day of the week	None	0
	Interval in weeks	1	0
	Start time	3:00	0
	Maximum time	3.0h	1
	Time for warm-keeping	1.0h	1
Hot water program	Active program	Always hot water	0
	View/edit active program		0
Hot water mode		Economy	0
Hot water settings heat pump x	Hot water production	Yes/No	1
Block heating during hot water demand		No	1
Maximum operating time for hot water at heating demand		30 min	1
Protective anode installed		Yes/No	1

Table 170 Factory settings Hot water

External control			F value	Access level
Heat pump x	External input 1, 2	Invert input	No	1
		Block additional heat 100% at triggered power guard	No	1
		Max output additional heat at triggered power guard	Off	1
		Block compressor x	No	0
		Block additional heat	No	0
		Block heating at tripped underfloor temperature limiter	No	1
		Block heating	No	0
		Room temperature	No (0,0 °C)	0
		Block hot water production	No	0
		Start collector circuit pump	No	1
		Alarm at low pressure in collector circuit	No	1
		External input circuit 2, 3...		Invert input
Block heating at tripped underfloor temperature limiter	No			1
Block heating	No			0
Room temperature	No (0,0 °C)			0

Table 171 Factory value External control

Installer			F value	Access level
General	Anti-seizure mode	Day of the week	Wednesday	1
		Start time	12:00	1
	Highest permitted flow temperature T1	Radiator/Underfloor	80/45 °C	1
	Operating mode			1
	Groundwater	Groundwater	No	1
		Compressor start delay groundwater	15s	1
	Display light switch off delay		5 min	1
Time for reset of access level		20 min	1	
Heat pump x capacity		(Start-up)	1	
Connected I/O boards	Shows which circuit boards are connected and their program version			1
Compressor working area	Outdoor stop function activated	No	1	
Circulation pumps	Heating circuit pump G1	Operation alternative	Continuous	1
		Heat carrier pump G2	Operation alternative	Continuous
		Pump speed E2x		
		> Fixed pump speed	Auto	1
		> Temperature difference heat transfer fluid when heating	7K	1
		> Temperature difference heat transfer fluid when hot water	7K	1
		> Pump speed at no demand Regulator settings	10%	1
		> P constant	3.0	1
> I constant	300.0	1		
Collector circuit pump G3	Operation alternative	Automatic	1	

Table 172 Factory settings Installer

Additional heat			F value	Access level
Additional heat general	Start delay		60 min	1
	Additional heat only		No	1
	Block additional heat		No	1
	Maximum outdoor temperature for additional heat		10 °C	1
Electric additional heat	Electric heater connection	Output per heater	9kW	1
		Output limitation in compressor mode	6kW	1
		Output limitation when additional heat only	6kW	1
		Output limitation in hot water mode	6kW	1
	Regulator settings	P constant	4,0	1
		I constant	300,0	1
		D constant	0,0	1
	Minimum PID signal	0%	1	
	Maximum PID signal	100%	1	
Hot water electric heater	Acknowledge hot water additional heat			1
Additional heat program	Active program		No	1
	View/edit active program			1
	Outdoor temperature limit for deactivation of time control		-26,0 °C	1

Table 173 Factory settings Additional heat

Safety functions			F value	Access level
Setting collector circuit in T10	Lowest permitted temperature E21.T10		-6,0 °C	1
			4,0 °C Groundwater	
	Lowest permitted temperature E22.T10		-6,0 °C	1
			4,0 °C Groundwater	
	Hysteresis alarm reset		1.0K	1
	Number of warnings before alarm		1	1
Setting collector circuit out T11	Lowest permitted temperature E21.T11		-8,0 °C	1
			2,0 °C Groundwater	
	Lowest permitted temperature E22.T11		-8,0 °C	1
			2,0 °C Groundwater	
	Hysteresis alarm reset		1.0K	1
	Number of warnings before alarm		1	1

Table 174 Factory settings Safety functions

General			F value	Access level
Room sensor settings	Show outdoor temperature in room sensor		No	0
Set date				0
Set time				0
Summer/winter time			Automatic	0
Display contrast			70%	0
Language				0
Country			(Start-up)	1

Table 175 Factory value General

Alarms			F value	Access level
Alarm indication	Alarm buzzer signal	Interval	2s	0
		Blocking time	Off	0
	Alarm indication control unit	Block alarm buzzer	No	0
	Alarm indication room sensor	Block alarm indicator lamp	No	0
	General alarm level	Alarms and warnings	No	1

Table 176 Factory settings Alarm

## 19 Environmental protection

Environmental protection is a fundamental corporate strategy of the Bosch Group.

The quality of our products, their economy and environmental safety are all of equal importance to us and all environmental protection legislation and regulations are strictly observed.

We use the best possible technology and materials for protecting the environment taking account of economic considerations.

### **Packaging**

We participate in the recycling programmes of the countries in which our products are sold to ensure optimum recycling.

All of our packaging materials are environmentally compatible and can be recycled.

### **Old products**

Old products contain materials which should be sorted.

Component groups are simple to differentiate and the materials are marked. In this way, the different component groups are sorted and handed over for recycling or waste disposal, respectively.

## 20 Maintenance



**DANGER:** Risk of electric shock!

- ▶ Switch off the main power supply before starting work on the electrical part.

We recommend that a function check be performed regularly by an authorised installer.

- ▶ Only use genuine spare parts!
- ▶ Refer to the spare parts list when ordering spare parts.
- ▶ Always renew seals and O-rings removed during servicing or repair work.

During service, the activities described below should be conducted.

### Show alarms

- ▶ Check the alarm log (→ Chapter 17.10 ).

### Function check

- ▶ A function check should be performed in connection with each service (→ Page 42).

### Electrical cable routing

- ▶ Check the electrical cable routing with regard to mechanical damage and replace defective cables.

### Check the particle filters for the heating system and collector system

The filters prevent dirt from entering the heat pump. If they are clogged, they can cause malfunctions.



It is not necessary to empty the installation in order to clean the filters. Filter and shut-off valve are integrated.

- ▶ Turn off the heat pump.
- ▶ Close the valve.
- ▶ Loosen the lid.
- ▶ Remove the circlip with the circlip pliers.
- ▶ Pull the filter out and clean it, if necessary, under running water.

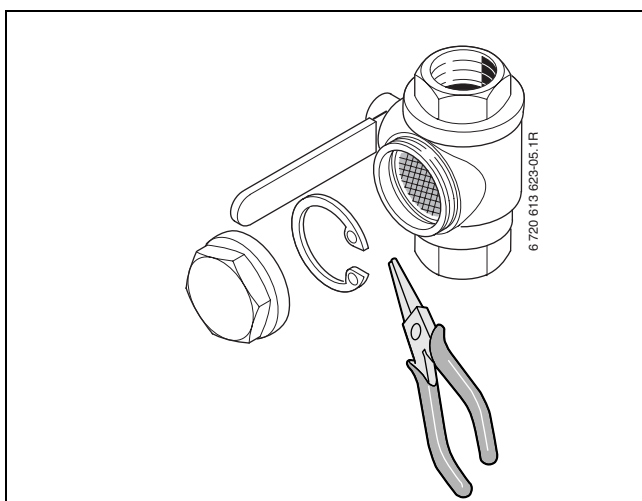

Fig. 53

- ▶ Put the parts back again in reverse order.

## 21 Commissioning protocol Greenline HE

Customer/responsible for installation:	
Installer of installation:	
Heat pump type:	Serial number:
Commissioning date:	Date of manufacture:
Type of collector:	Total length of collector:
Other components in the installation:	
Additional heat <input type="checkbox"/>	Room sensor T5 <input type="checkbox"/>
Water heater <input type="checkbox"/>	Exhaust air collector <input type="checkbox"/>
3-way valve <input type="checkbox"/>	Hot water sensor T3 <input type="checkbox"/>
	Flow line sensor heating circuit 2 E12.T1 <input type="checkbox"/>
Miscellaneous:	
<b>The following work has been carried out:</b>	
Heating system: filled <input type="checkbox"/> vented <input type="checkbox"/> particle filter cleaned <input type="checkbox"/> minimum flow ensured <input type="checkbox"/> installation of T1 checked <input type="checkbox"/> Heat curve set <input type="checkbox"/>	
Collector system: filled <input type="checkbox"/> vented <input type="checkbox"/> particle filter cleaned <input type="checkbox"/> vents installed <input type="checkbox"/> collector fluid concentration checked <input type="checkbox"/>	
Electrical connection: performed <input type="checkbox"/> motor cut-out settings checked <input type="checkbox"/>	
Sight glass: checked <input type="checkbox"/> notes:	
<b>Operating temperatures after 10 minutes heating/hot water operation:</b>	
Heat transfer fluid out (T8):..... °C	Heat transfer fluid in (T9):..... °C
Temperature difference between Heat transfer fluid out (T8) and in (T9) approx. 6 ... 10 K (°C) <input type="checkbox"/>	
Collector circuit in (T10): ..... °C	Collector circuit out (T11): ..... °C
Temperature difference between Collector circuit in (T10) and Collector circuit out (T11) approx. 2 ... 5 K (°C) <input type="checkbox"/>	
Setting heat carrier pump (G2):	Setting collector circuit pump (G3):
Leak test for heating system and collector system carried out <input type="checkbox"/>	
Function check carried out <input type="checkbox"/>	
Customer/responsible for installation: has been informed of how to operate the heat pump <input type="checkbox"/>	
Documentation handed over <input type="checkbox"/>	
Date and signature of installation installer:	

Table 177

---

## Notes



**POWERED BY NATURE**

Alto Energy Limited  
Unit 17 Glenmore Business Centre  
Witney, Oxfordshire, OX29 0AA, United Kingdom  
[www.altoenergy.co.uk](http://www.altoenergy.co.uk) | [info@altoenergy.co.uk](mailto:info@altoenergy.co.uk)