

Product Specifications

Model No.	HV3688T-BLK	HV3688T-WHT
Name	Lesen	
Material	Aluminium	
Colour	Black	White
IP Rating	IP20	
Installation Type	Wall - Surface Mounted	
Input Voltage	240v AC	
Protection Class	1 (Requires Earth)	
Lamp Base	Built in LED	
Lamp Wattage	2x 3w	
Colour Temp	TRI Colour - 3000k, 4000k, 5500k	
Lumens	2x 100lm, 2x 110lm, 2x 105lm	
CRI	>80+	
Dimmable	Yes - Built in Dimming	
Warranty	3 Years Replacement*	

Important Safety Issues:

- This product must be installed by a qualified electrician according to AS/NZS 3000.
- Ensure all electrical mains are disconnected before any installation.
- Modification of this product will void any warranty.
- Havit Lighting does not take responsibility for wrong installation, incorrect use, or use of installation material that does not belong to the system.
- Aluminium and 304SS fittings must not be installed within 5km of any salt water environments.
- All o-rings and seals must be in place correctly to maintain warranty
- This form may be updated at any time due to product improvements, please check online installation form for most current version.

Dimensions

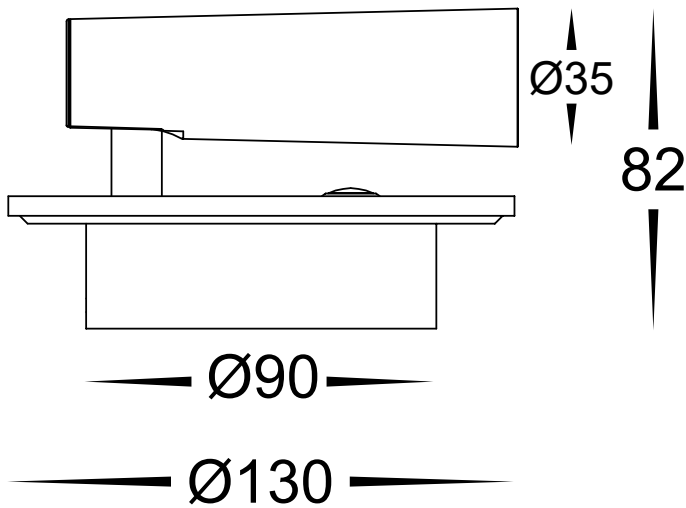

Mounting Base

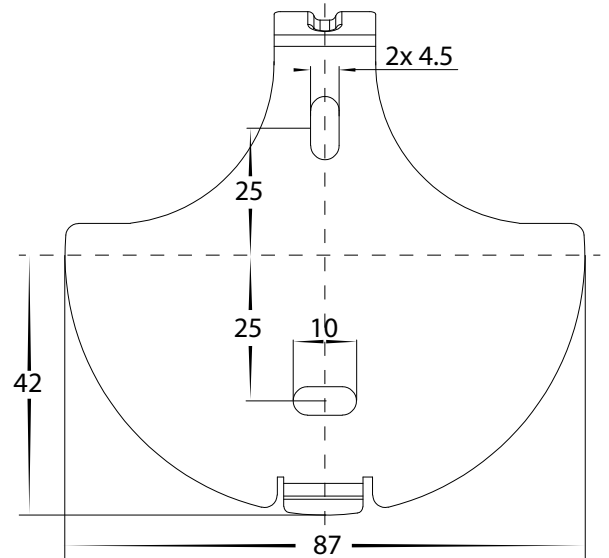

Steps for Installation:

1. Make sure that the electrical circuit is free of voltage (master switch off)
2. Loosen allen screw on side of fitting and remove mounting base.
3. Install mounting base in desired location using appropriate screws for application
4. Connect the cable - use wire with earth; connect the earth first, then live and neutral wire
5. Reattach fitting to base plate making sure allen screws are tight.
6. Adjust fitting to desired position making sure to stop rotating when fitting cannot rotate anymore, If forced fitting will continue to rotate and cause internal cables to become entangled causing fitting to short. If this is done, warranty will be voided.
7. Press switches to turn fitting on and off
8. To change colour temperature, press switches twice quickly to cycle through each colour.
9. To dim fitting, hold down switch to desired light level and release, To make fitting brighter also hold down switch
10. All connections must be carried out carefully, inspect all contacts before switching back on the electric circuit.

Must be installed by a licensed electrician

Contact Details:

143 Beauchamp Road
Matraville NSW 2036
Australia
Tel: 02 9381 8300
Fax: 02 9666 8881
Email: sales@havit.com.au
Web: www.havit.com.au

Warranty Terms & Conditions*



www.havit.com.au

