



# Feiyu Pocket 2

Quick Start Guide

快速入门

Kurzanleitung

Guide de Démarrage Rapide

Guía de Inicio Rápido

Inizio rapido

V 1.0

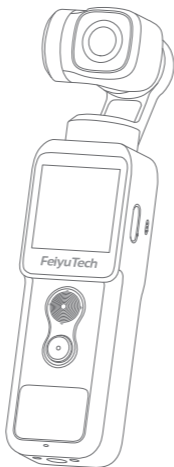

EN	Quick Start Guide	3/
CN	快速入门	7/
DE	Kurzanleitung	11/
FR	Guide de Démarrage Rapide	15/
ES	Guía de Inicio Rápido	19/
IT	Inizio rapido	23/

# Feiyu Pocket 2

Quick Start Guide V 1.0

**EN** CN DE FR ES IT

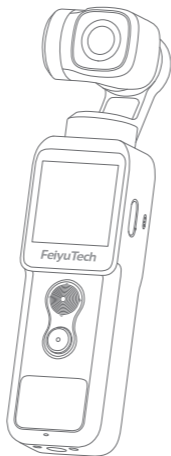

Tutorial Videos



# 1. Overview

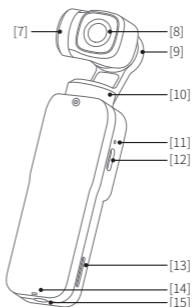
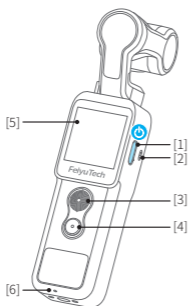
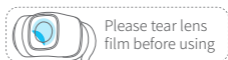

- [1] Power Button
- [2] Loudspeaker
- [3] Joystick / Function Button
- [4] Shutter Button / Indicator
- [5] Touch Screen
- [6] Microphone

- [7] Tilt Axis
- [8] Camera Lens
- [9] Roll Axis
- [10] Pan Axis
- [11] Charging Indicator
- [12] USB-C Charging Port
- [13] MicroSD Card Slot
- [14] Wrist Strap Hole
- [15] 1/4 inch Thread Hole

## LIST



- ① Feiyu Pocket 2 x 1
- ② Protective cover x 1
- ③ USB-C cable x 1

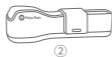

- ④ Wrist strap x 1
- ⑤ Manual x 1



## User manual

Follow the steps below to quickly experience the basic features of Feiyu Pocket 2. Read the detailed manual for more usage of the camera.

<https://www.feiyu-tech.com/feiyu-pocket-2/>



## Download the App

Scan the QR code to download the app, or search for "**Feiyu Cam**" in the App Store or Google Play.

\* Requires iOS 9.0 or above, Android 6.0 or above.



iOS





Android

## 2. Start to Use

### 2.1 Charging

Connect USB-C cable with charging port to charge Feiyu Pocket 2.

**We recommend that you charge your camera at least once a month.**

Charging Status	While Working (Screen status)	While OFF (Indicator status)
Charging	 Display	Red light is on
Complete	 Disappear	Green light is on

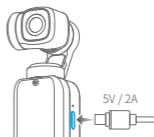

### 2.2 Insert MicroSD Card

An UHS - I Speed Grade 3 (U3) rating microSD card (equipped by user) is required.

**Please format the microSD card with Feiyu Pocket S when insert it at the first time.**



## 2.3 Common Operations

### Power Button

**Long press for 1s:** Power ON/ OFF

**Single tap:**

- (1) Switch among video/ photo mode/ recently used function
- (2) Return to the previous menu



### Joystick/Function Button

**Move to left/ right:** Control pan axis

**Move upward/downward:** Control tilt axis

**Double tap:** Recenter

**Triple tap:** Enter/Exit selfie mode

**Press and hold:** Enter lock mode

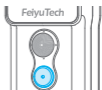

### Enter lock mode

**Single tap:** Take photo/ video/ return to the home page

**Long press for 3s:** Turn on/ off Wi-Fi

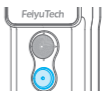

### Touch Screen

**Swipe to Left:** Switch shooting modes

**Swipe to right:** Enter album

**Swipe upward:** Enter album

**Swipe downward:** Enter setting



## 2.4 Storage

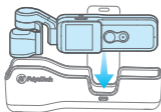

◀ Put in the protective cover

▼ Storage status

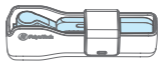

## 3. Specifications

Product name: Feiyu Pocket 2 Stabilized Camera

Product model: Vcam2

Controllable Tilt Range: 280°

Controllable Roll Range: 180°

Controllable Pan Range: 314°

Battery Capacity: 875mAh

Charging Time: 1.2h

Working Time: 220min (1080p@30fps)

Product Size: 124.6×40.6×29.8mm

Main Body Weight: 127g (Built-in battery, not including accessories)



# Feiyu Pocket 2

快速入门 V1.0

EN **CN** DE FR ES IT

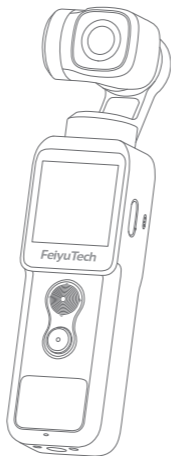

教学视频



## 1. 产品概览

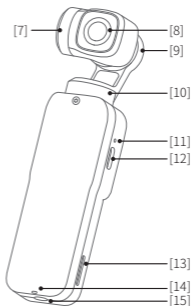
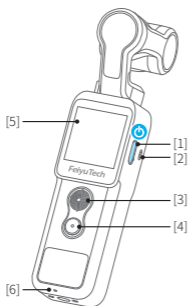

- [1] 电源键
- [2] 扬声器
- [3] 摇杆 / 功能键
- [4] 拍摄键 / 指示灯
- [5] 触摸显示屏
- [6] 麦克风
- [7] 俯仰轴
- [8] 相机镜头

- [9] 横滚轴
- [10] 航向轴
- [11] 充电指示灯
- [12] Type-C 充电接口
- [13] MicroSD 卡槽
- [14] 绳孔
- [15] 1/4 英寸螺纹孔

## 清单



- ① 主机 x 1
- ② 保护套 x 1
- ③ Type-C 数据线 x 1

- ④ 防丢绳 x 1
- ⑤ 说明书 x 1



## 详细说明书

按以下步骤操作可快速体验产品的基本功能。更多功能的使用请参阅详细说明书

<https://www.feiyu-tech.cn/feiyu-pocket-2/>



## 下载 App

扫描二维码或在应用商店搜索“**Feiyu Cam**”下载。

\* 系统要求：iOS 9.0 或更高版本，Android 6.0 或更高版本

\* Android 版本请使用浏览器扫描二维码下载



iOS



Android

## 2. 使用

### 2.1 充电

使用 Type-C 数据线连接充电接口充电。  
建议每月至少充电一次。

充电状态	开机充电 (显示屏指示)	关机充电 (充电指示灯指示)
充电中	显示	红灯亮
充电完成	消失	绿灯亮

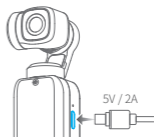

### 2.2 安装 MicroSD 卡

建议使用传输速度达到 UHS - I Speed Grade 3 (U3) 评级的 microSD 卡 (自备)。

初次安装的 microSD 卡，建议使用本产品格式化后再存储数据。



## 2.3 常用操作

### 电源键

长按 1 秒：开 / 关机

单击：

(1) 切换拍照 / 录像 / 最近使用功能

(2) 返回上级菜单



### 摇杆 / 功能键

左 / 右拨动：控制航向

上 / 下拨动：控制俯仰

双击：回中

三连击：进入 / 退出自拍模式

按住：进入锁定模式



### 拍摄键

单击：拍照 / 录像 / 返回主界面

长按 3 秒：开 / 关 Wi-Fi

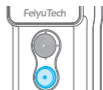

### 触摸显示屏

向左滑动：切换拍摄模式

向右滑动：进入相册

向上滑动：云台控制

向下滑动：进入设置



## 2.4 收纳

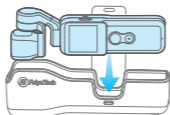

- ◀ 放入保护套中
- ▼ 收纳状态

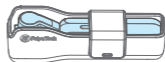

## 3. 参数

产品名 :Feiyu Pocket 2 口袋云台相机

型号 :Vcam2

充电时长 : 1.2 小时

俯仰可控角度 : 280°

工作时间 : 220 分钟 (1080p@30fps)

横滚可控角度 : 180°

产品尺寸 : 124.6×40.6×29.8mm

航向可控角度 : 314°

主机重量 : 127g (内置电池, 不含配件)

内置电池容量 : 875mAh

# Feiyu Pocket 2

Kurzanleitung V 1.0

EN CN **DE** FR ES IT

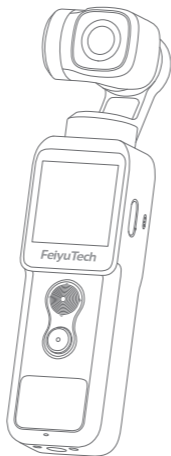

Tutorial Videos



# 1. Übersicht

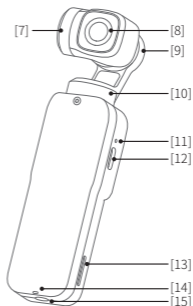
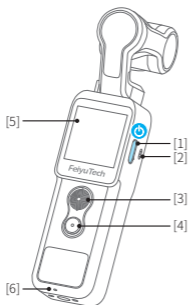

- [1] Netzschalter
- [2] Lautsprecher
- [3] Joystick/Funktionstaste
- [4] Aufnahmetaste/Anzeige
- [5] Touchscreen
- [6] Mikrofon
- [7] Kipp-Achse
- [8] Kameraobjektiv

- [9] Roll-Achse
- [10] Pan-Achse
- [11] Ladekontrollleuchte
- [12] USB-C-Ladeanschluss
- [13] Micro-SD-Kartensteckplatz
- [14] Loch für andgelenkriemen
- [15] 1/4 Zoll Gewindebohrung

## LISTE

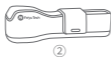

- ① Feiyu Pocket 2 x 1
- ② Schutzhülle x 1
- ③ USB-C-Kabel x 1

- ④ Handgelenkband x 1
- ⑤ Handbuch x 1

## Ausführliches Handbuch

Befolgen Sie die folgenden Schritte, um die grundlegenden Funktionen von Feiyu Pocket 2 schnell kennenzulernen. Lesen Sie das ausführliche Handbuch, um mehr über die Verwendung der Kamera zu erfahren.



<https://www.feiyu-tech.com/feiyu-pocket-2/>

## App herunterladen

Verbinden Sie sich mit der Feiyu Cam App, um mehr Funktionen zu erhalten.

Scannen Sie den QR-Code, um die App herunterzuladen, oder suchen Sie nach **"Feiyu Cam"** im App Store oder bei Google Play.

\* Benötigt iOS 9.0 oder höher, Android 6.0 oder höher.



iOS



Android

## 2. Start zur Verwendung

### 2.1 Aufladen

Verwenden Sie ein Typ-C-Kabel zum Anschluss an den Ladeanschluss zum Aufladen.

**Wir empfehlen Ihnen, die Kamera mindestens einmal im Monat zu laden.**

Status der Ladung	Während der Arbeit (Bildschirmstatus)	Während AUS (Status der Anzeige)
Laden	Anzeige	Rotes Licht leuchtet
Beenden	Ausblenden	Grünes Licht leuchtet

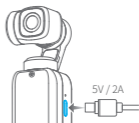

### 2.2 Micro-SD-Karte einlegen

Eine Micro-SD-Karte mit UHS - I Geschwindigkeitsstufe 3 (U3), die vom Benutzer ausgestattet wurde, ist erforderlich.

**Bitte formatieren Sie die Micro-SD-Karte mit dem Feiyu Pocket 2, wenn Sie sie zum ersten Mal einlegen.**



## 2.3 Allgemeine Bedienung

### Netzschalter

**Langes Drücken für 1s:** Strom EIN/AUS

**Einfaches Antippen:**

(1) Umschalten zwischen Video-/Fotomodus/zuletzt verwendete Funktion

(2) Rückkehr zum vorherigen Menü

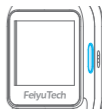

### Joystick/Function Button

**Einfaches Antippen:** Steuerung Schwenkachse

**Aufwärts/abwärts bewegen:** Steuerung der Neigeachse

**Doppeltippen :** Neu ausrichten

**Dreifach-Klicken:** Selbstauslöser-Modus

**Neu ausrichten:** Sperrmodus eingeben



### Aufnahmetaste

**Einfaches Antippen:** Foto/ Video aufnehmen/

**Langes Drücken für 3s:** Wi-Fi ein-/ausschalten

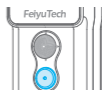

### Touch Screen

**Wischen nach links:** Aufnahmemodus umschalten

**Wischen nach rechts:** Album aufrufen

**Wischen nach oben:** Kardanische Steuerung

**Wischen nach unten:** Einstellung eingeben



## 2.4 Lagerung

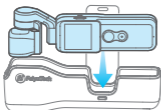

◀ In die Schutzhülle stecken

▼ Lagerungszustand

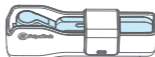

## 3. Spezifikationen

Produktbezeichnung: Feiyu Pocket 2 Stabilisierte Kamera

Produkt-Modell: Vcam2

Kontrollierbarer Neigebereich: 280°

Kontrollierbarer Rollbereich: 180°

Steuerbarer Pan-Bereich: 314°

Akku-Kapazität: 875mAh

Aufladezeit: 1.2h

Betriebszeit: 220min (1080p@30fps)

Produktgröße:

124.6×40.6×29.8mm

Gewicht des Hauptgehäuses: 127g  
(Eingebauter Akku, nicht inklusive  
Zubehör)

# Feiyu Pocket 2

Guide de Démarrage Rapide V1.0

EN CN DE **FR** ES IT

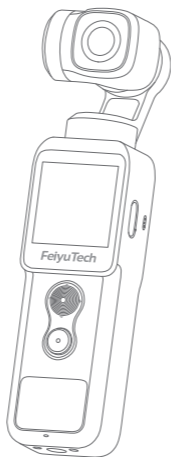

Vidéos des tutoriels



# 1. Aperçu

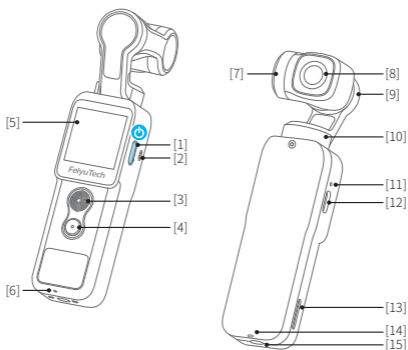
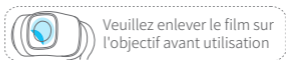

- [1] Alimentation
- [2] Haut-parleur
- [3] Joystick/Bouton de fonction
- [4] Bouton Déclencheur/Voyant
- [5] Ecran tactile
- [6] Micro

- [7] Axe d'Inclinaison
- [8] Objectif de la caméra
- [9] Axe de Roulis
- [10] Axe Panoramique
- [11] Témoin de charge
- [12] Port de chargement USB-C
- [13] Fente pour carte MicroSD
- [14] Trou pour sangle de poignet
- [15] Trou fileté de 1/4 pouce

## Liste de colisage



- |                        |     |                     |     |
|------------------------|-----|---------------------|-----|
| ① Feiyu Pocket 2       | x 1 | ④ Sangle de poignet | x 1 |
| ② Housse de protection | x 1 | ⑤ Manuel            | x 1 |
| ③ Câble USB-C          | x 1 |                     |     |



## Manuel détaillé

Suivez les étapes ci-dessous pour découvrir rapidement les fonctions de base du produit Feiyu pocket 2. Pour plus de fonctionnalités, veuillez vous référer au manuel détaillé.

<https://www.feiyu-tech.com/feiyu-pocket-2/>



## Télécharger l'application

Connectez à l'App Feiyu Cam pour réaliser plus de fonctions.

Scannez le code QR pour télécharger l'application, ou recherchez "**Feiyu Cam**" dans l'App Store ou Google Play.

\* Scannez le code QR pour télécharger l'application, ou recherchez "Feiyu Cam" dans l'App Store ou Google Play.



iOS



Android

## 2. Mise en route

### 2.1 Chargement électrique

Connectez le câble USB-C avec le port de chargement pour recharger le Feiyu Pocket 2.

**Il est recommandé de charger le produit au moins une fois par mois.**

Etat de Charge	L'appareil en marche (affiché sur l'écran)	L'appareil en arrêt (indiqué par le témoin)
Charge en cours	Affiché	Témoin rouge s'allume
Terminé	Disparu	Témoin vert s'allume

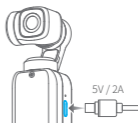

### 2.2 Témoin de charge

Il est recommandé d'utiliser une carte microSD UHS-I au Niveau de Vitesse 3 (U3) (équipée par l'utilisateur).

**Il est recommandé d'utiliser une carte microSD UHS-I au Niveau de Vitesse 3 (U3) (équipée par l'utilisateur).**

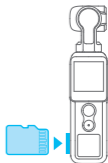

## 2.3 Opérations Courantes

### Alimentation

**Appui long pendant 1s:** Démarrage/Arrêt

**Simple Clic:**

(1) Basculez entre modes Photo /Vidéo/Fonction récemment utilisée

(2) Revenez au menu précédent



### Joystick/Bouton de fonction

**Déplacez vers la gauche/droite:** Contrôle de l'axe panoramique

**Déplacez vers le haut/bas:** Contrôle de l'axe d'inclinaison

**Double Clic:** Recentrer

**Triple tape:** Mode selfie

**Appuyez longuement:** Passer en mode verrouillage



### Bouton Déclencheur

**Simple Clic:** Prendre Photo/Vidéo/Revenez à la page

**Appui long pendant 3s:** Activez/Désactivez le Wi-Fi

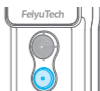

### Ecran tactile

**Ecran tactile:** Changer de mode de prise de vue

**Glissez vers la droite:** Entrer dans l'album

**Glissez vers le haut:** Contrôle du Cardan

**Glissez vers le bas:** Accéder aux réglages

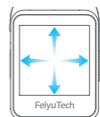

## 2.4 Stockage

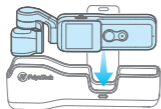

◀ Mettez-le dans la housse de protection

▼ Etat de stockage

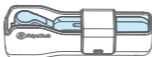

## 3. Spécifications

Désignation du produit: Caméra stabilisé Feiyu Pocket 2

Modèle: Vcam 2

Angle d'Inclinaison réglable: 280°

Angle de Roulement réglable : 180°

Angle de Panoramique réglable: 314°

Capacité de la Batterie: 875mAh

Temps de charge: 1,2 h

Temps de travail: 220m  
(1080p@30fps)

Dimensions:  
124.6×40.6×29.8mm

Poids de l'unité principale: 127g  
(Batterie intégrée, les accessoires non inclus)

# Feiyu Pocket 2

Guía de Inicio Rápido V 1.0

EN CN DE FR **ES** IT

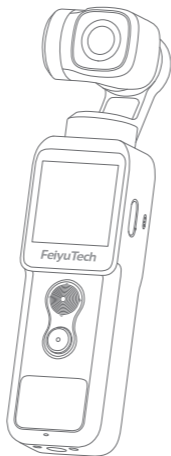

Vídeos Tutoriales



# 1. Información general

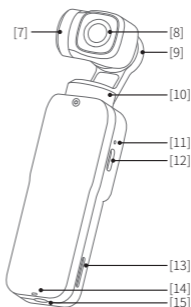
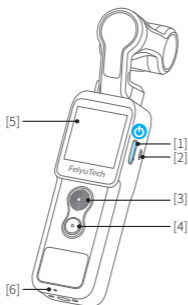

- [1] Botón de encendido
- [2] Altavoz
- [3] Botón de función/Joystick
- [4] Botón/indicador de obturador
- [5] Pantalla táctil
- [6] Micrófono

- [7] Eje de inclinación
- [8] Lente de la cámara
- [9] Eje de balanceo
- [10] Eje de panorámica
- [11] Indicador de carga
- [12] Puerto de carga USB-C
- [13] Ranura para tarjeta MicroSD
- [14] Orificio para correa de muñeca
- [15] Orificio de rosca de 1/4 de pulgada

## LISTA



- ① Feiyu Pocket 2 x 1
- ② Cubierta protectora x 1
- ③ Cable USB-C x 1

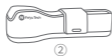

- ④ Correa para la muñeca x 1
- ⑤ Manual x 1

## Manual detallado

Siga los pasos a continuación para experimentar rápidamente las características básicas de Feiyu Bolsillo. Lea el manual detallado para obtener más información sobre el uso de la cámara.



<https://www.feiyu-tech.com/feiyu-pocket-2/>

## Descargar App

Escanee el código QR para descargar la App o busque "Feiyu Cam" en la App Store o Google Play.

\* Requiere iOS 9.0 o superior, Android 6.0 o superior.



iOS



Android

## 2. Empezar a usar

### 2.1 Cargar

Conecte el cable USB-C con el puerto de carga para cargar el Feiyu Bolsillo 2.

Se recomienda que cargue su cámara al menos una vez al mes.

Estado de carga	Mientras funciona (estado de pantalla)	Mientras está APAGADO (estado del indicador)
Cargando	🔌 Exhibir	La luz roja está encendida
Completar	🔌 Desaparecer	La luz verde está encendida

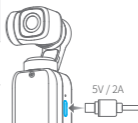

### 2.2 Inserte la tarjeta microSD

Se requiere una tarjeta microSD con calificación UHS - I Speed Grade 3 (U3) (equipada por el usuario).

Formatee la tarjeta microSD con Feiyu Bolsillo 2 la primera vez que utilice nueva tarjeta SD.



## 2.3 Common Operations

### Botón de Encendido

**Mantener pulsado durante 1 segundos:** Encendido/ Apagado

**Solo toque:** (1) Cambiar entre modo Video/Foto/  
Función usada recientemente  
(2) Regresar al menú anterior



### Botón de Joystick/Función

**Mover a la izquierda/derecha:** Control de eje de panorámica

**Mover hacia arriba/hacia abajo:** Controlar el eje de inclinación

**Doble toque:** Volver a centrar

**Triple toque:** Entrar / salir del modo Selfie

**Pulsar y mantenga:** Entrar en modo de bloqueo



### Botón del obturador

**Solo toque:** Tomar foto/video/regresar a la página de inicio

**Mantener pulsado durante 3 segundos:** Activar/  
desactivar Wi-Fi

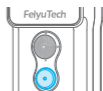

### Pantalla táctil

**Desliza hacia la izquierda:** Cambiar el modo de fotografiar

**Desliza hacia la derecha:** Entrar en álbum

**Deslizar hacia arriba:** Control de cardán

**Deslizar hacia abajo:** Entrar en ajuste



## 2.4 Almacenamiento

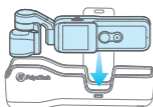

- ◀ Ponga la funda protectora
- ▼ Estado de almacenamiento

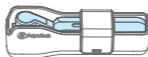

## 3. Especificaciones

Nombre del producto: Feiyu Bolsillo 2 Cámara Estabilizada

Modelo: Vcam2

Rango de inclinación controlable: 280°

Rango de balanceo controlable: 180°

Rango de panorámica controlable: 314°

Capacidad de batería: 875mAh

Tiempo de carga: 1.2h

Tiempo de funcionamiento: 220min  
(1080p@30fps)

Tamaño del producto:  
124.6×40.6×29.8mm

Peso de unidad principal: 127g  
(Batería incorporada, sin incluir accesorios)

# Feiyu Pocket 2

Inizio rapido

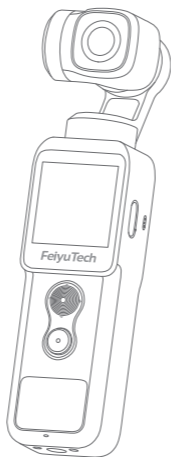

Video Didattico



## 1. Panoramica



Si prega di strappare la pellicola della lente prima dell'uso

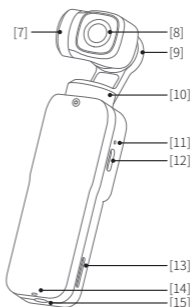
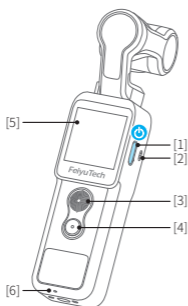

- [1] Tasto di accensione
- [2] Altoparlante
- [3] Pulsante / tasto funzione
- [4] Tasto di ripresa / indicatore
- [5] Schermo tattile
- [6] Microfono
- [7] Asse del passo
- [8] Lente della macchina fotografica

- [9] Rullo
- [10] Asse di direzione
- [11] Indicatore di carica
- [12] Interfaccia di ricarica Type-C
- [13] Slot per scheda MicroSD
- [14] Foro per la corda
- [15] Foro filettato da 1/4 di pollice

## Elenco dettagliato



① Host

x 1

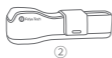

② Copertura intelligente

x 1



③ Linea dati Type-C

x 1



④ Corda anti-perdita

x 1



⑤ Istruzioni

x 1



## Istruzioni dettagliate

Seguite i passi qui sotto per sperimentare rapidamente le funzioni di base del prodotto. Per ulteriori funzioni, si prega di fare riferimento al manuale dettagliato.

<https://www.feiyu-tech.com/feiyu-pocket-2/>



## Scaricare l'App

Scansiona il codice QR o cerca nell'app store "**Feiyu Cam**" per scaricare

\* Requisiti di sistema: IOS 9.0 o superiore, Android 6.0 o superiore.



iOS



Android

## 2. Utilizzare

### 2.1 Carica

Utilizzare il cavo dati di Tipo C per collegare l'interfaccia di ricarica per la ricarica.

**Si raccomanda di caricare almeno una volta al mese.**

Stato di carica	Alimentazione in carica (indicato sul display)	Spegnimento della carica (indicazione luminosa)
Carica	☑ Isualizzare	La luce rossa è accesa
Carica completa	☑ Scomparire	La luce verde è accesa

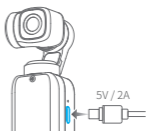

### 2.2 Installazione della scheda MicroSD

Quando si installa una scheda microSD, si raccomanda di usare una scheda microSD con velocità di trasmissione fino a UHS - I grado di velocità 3 (U3) (auto fornita).

**Per la scheda microSD installata per la prima volta, si raccomanda di usare questo prodotto per formattare e poi memorizzare i dati.**



## 2.3 Funzionamento comune

### Tasto di accensione

Tenere premuto per 1 secondo: ON/ OFF

Clic singolo:

(1) Passa dalla funzione di fotografia / registrazione / uso recente

(2) Ritorno al menu principale



### Tasto basculante/funzione

Sinistra / destra Toggle: Controllo rotta

Su / giù Alterna: Controllo del passo

Doppio clic: Hui Zhong

Triplo colpo: entra/esci dalla modalità selfie

Premere e tenere premuto: Entrare in modalità di blocco

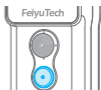

### Tasto di ripresa

Clic singolo: Scattare foto / video / tornare all'interfaccia principale

Tenere premuto per 3 secondo: Attivare / disattivare il Wi-Fi

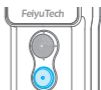

### Schermo tattile

Scorri a sinistra: Cambiare modalità di scatto

Scorrere a destra: Entrare nell'album

Strofinare verso l'alto: Controllo PTZ

Scorrere verso il basso: Entrare nelle impostazioni



## 2.4 Conservazione

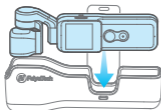

◀ Put in the protective cover

▼ Storage status

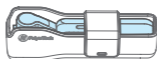

## 3. Parametro

Nome del prodotto: Feiyu pocket 2 pocket pan tilt camera

Modello: Vcam2

Angolo di beccheggio controllabile: 280°

Angolo di rotolamento controllabile: 180°

Angolo di direzione controllabile: 314°

Capacità della batteria incorporata:

875mAh

Tempo di ricarica: 1,2 ore

Tempo di lavoro: 220min

(1080p@30fps)

Dimensione del prodotto:

124.6×40.6×29.8mm

Peso dell'host: 127g (Batteria

integrata, esclusi gli accessori)

EN

### Notice

1. Make sure motor spinning is not blocked by external force when the product is power on.
2. The product DO NOT contact water or other liquid if the product is not mark waterproof or splash-proof. Waterproof and splash-proof product DO NOT contact sea water or other corrosive liquid.
3. DO NOT disassembly the product except marked detachable. It need send to FeiyuTech after-sales or authorized service center to fix it if you accidently disassembly and cause abnormal work. The relevant costs are borne by user.
4. Prolonged continuous operation may cause the product surface temperature to rise, please operate carefully.
5. DO NOT drop or strike the product. If the product is abnormal, contact Feiyu After-sales support.

### Storage and Maintenance

1. Keep the product out of the reach of children and pets.
2. DO NOT leave the product near heat sources such as a furnace or heater. DO NOT leave the product inside of a vehicle on hot days.
3. Please storage the product in dry environment.
4. DO NOT overcharge or overuse the battery, otherwise it will cause damage to the battery core. If does not use the product for a long time, please charge it at least once within one month.
5. Never use the product when the temperature is too high or too low.

CN

### 注意

1. 确保本产品开启过程及开启后，电机转动不受外力阻挡。
2. 请勿将本产品接触到水或其他液体。
3. 请勿拆卸产品整机，如不慎拆开导致工作异常，请寄回重新调试。由此产生的费用全部由客户承担。
4. 长时间持续工作可能导致产品表面温度升高，请谨慎操作。
5. 严禁摔落或碰撞，摔落或碰撞本产品，有可能使其损坏，导致工作异常。如出现摔落或碰撞导致工作异常，请及时联系售后。

### 存储和保养

1. 请将本产品存放在儿童及宠物接触不到的地方。
2. 禁止将本产品放在靠近热源（火炉或加热器等）的地方以及置于热天的汽车内。
3. 请在干燥的环境中存储。
4. 切勿过充、过放电池，否则将对电芯造成损害。长时间不使用时，建议至少充电 1 次 / 月。
5. 切勿在温度太高或太低的环境下使用本产品。

## 免责声明

感谢您选用本产品。本文所提及的内容关系到您的安全、合法权益及责任，请务必认真阅读，以及按照指导正确设置和使用本产品。不按照本文的说明和注意事项来操作，可能会给您和周围人带来伤害，损坏本产品或周围产品。禁止任何用户的任何非法用途。用户将为购买和使用产品的一切行为负责。对于本产品，本公司不承担终端客户对本产品所有调试和使用当中的风险和责任（包括直接或间接或者第三方的损失）。

我公司对于任何从非正常渠道获得或不明用途的产品，将不予任何服务。

DE

## Hinweis

1. Stellen Sie sicher, dass die Motordrehung nicht durch externe Kräfte blockiert wird, wenn das Produkt eingeschaltet ist.
2. Das Produkt darf NICHT mit Wasser oder anderen Flüssigkeiten in Berührung kommen, wenn das Produkt nicht als wasserdicht oder spritzwassergeschützt gekennzeichnet ist. Das wasserdichte und spritzwassergeschützte Produkt darf NICHT mit Meerwasser oder anderen korrosiven Flüssigkeiten in Kontakt kommen.
3. Demontieren Sie das Produkt NICHT, es sei denn, es ist als abnehmbar gekennzeichnet. Wenn Sie das Produkt versehentlich zerlegen und dadurch eine Störung verursachen, müssen Sie es zur Reparatur an den FeiyuTech-Kundendienst oder ein autorisiertes Servicezentrum schicken. Die entsprechenden Kosten sind vom Benutzer zu tragen.
4. Längerer Dauerbetrieb kann zu einem Anstieg der Produktoberflächentemperatur führen, bitte bedienen Sie vorsichtig.
5. Lassen Sie das Produkt NICHT fallen und schlagen Sie nicht dagegen. Wenn das Produkt abnormal ist, kontaktieren Sie den Feiyu-Kundendienst.

## Lagerung und Wartung

1. Bewahren Sie das Produkt außerhalb der Reichweite von Kindern und Haustieren auf.
2. Stellen Sie dieses Produkt nicht in der Nähe einer Wärmequelle (Ofen oder Heizung usw.) oder an heißen Tagen in einem Auto auf.
3. Lagern Sie das Produkt bitte in einer trockenen Umgebung.
4. Überladen Sie den Akku NICHT und verwenden Sie ihn nicht zu oft, da dies zu Schäden am Akku führen kann. Wenn Sie das Produkt über einen längeren Zeitraum nicht verwenden, laden Sie es bitte mindestens einmal innerhalb eines Monats auf.
5. Verwenden Sie das Produkt niemals bei zu hohen oder zu niedrigen Temperaturen.

FR

## Remarques

1. Assurez-vous que la rotation du moteur ne sera pas bloquée par une force externe lorsque le produit est mise sous tension ou après son démarrage.
2. NE PAS exposer le produit à l'eau ou aux autres liquides .
3. NE démontez PAS le produit sauf s'il est marqué démontable. Il doit être envoyé au service après-vente pour le réparer si vous le démontez accidentellement et causez un fonctionnement anormal. Tous les frais qui en découlent seront à la charge du client.

4. Un fonctionnement continu prolongé peut entraîner la hausse de la température superficielle du produit, veuillez manipuler avec prudence.
5. La chute ou la collision du produit peut l'endommager et provoquer un fonctionnement anormal. En cas de dysfonctionnement à cause de la chute ou collision, veuillez contacter le service après-vente Feiyu.

## Stockage et Entretien

1. Gardez à l'écart des enfants et des animaux domestiques.
2. NE laissez pas le produit à proximité d'une source de chaleur (four ou réchauffeur, etc.) ni le placez à l'intérieur d'un véhicule lors des journées chaudes.
3. Veuillez le stocker dans un environnement sec.
4. NE surchargez ni surutilisez la batterie, sinon cela endommagera le noyau de la batterie. Pendant une période de non-utilisation prolongée, il est recommandé de le recharger au moins une fois/mois.
5. N'utilisez pas le produit dans un environnement à température trop élevée ou trop basse.

### FCC regulatory conformance:

This device complies with Part 15 of the FCC Rules. Operation is subject to the following two conditions:

- (1) This device may not cause harmful interference.
- (2) This device must accept any interference received, including interference that may cause undesired operation.

### **NOTE**

This equipment has been tested and found to comply with the limits for a Class B digital device, pursuant to part 15 of the FCC Rules. These limits are designed to provide reasonable protection against harmful interference in a residential installation.

This equipment generates uses and can radiate radio frequency energy and, if not installed and used in accordance with the instructions, may cause harmful interference to radio communications. However, there is no guarantee that interference will not occur in a particular installation. If this equipment does cause harmful interference to radio or television reception, which can be determined by turning the equipment off and on, the user is encouraged to try to correct the interference by one or more of the following measures:

- Reorient or relocate the receiving antenna.
- Increase the separation between the equipment and receiver.
- Connect the equipment into an outlet on a circuit different from that to which the receiver is connected.
- Consult the dealer or an experienced radio/TV technician for help.

### **NOTE**

The manufacturer is not responsible for any radio or TV interference caused by unauthorized modifications to this equipment. Such modifications could void the user's authority to operate the equipment.

### **RF Exposure**

This equipment complies with FCC radiation exposure limits set forth for an uncontrolled environment.

## Warranty Card / 售后服务卡

Product Model

产品型号

Serial Number

序列号

Purchase Date

购买日期

Customer Name

客户姓名

Customer Tel

客户电话

Customer Email

客户邮箱

### **Warranty:**

1. Within one year from the date of selling, the product is malfunctioning under normal due to non-artificial reasons.
2. The malfunction of the product is not caused by artificial reasons such as unauthorized disassemble or conversion or addition.
3. The buyer is able to provide the certificate of maintenance service: the warranty card, the legitimate receipts, invoices, or screenshot of purchasing.

### **The followings cases are not included under the warranty:**

1. Unable to provide legitimate receipt and warranty card with buyer's info.
  2. The damage caused by human or irresistible factor.
- More details about after-sales policy, please refer to after-sales page on website: <https://www.feiyu-tech.com/support>
- \* Our company reserves the right of final interpretation on the above-mentioned after sales terms and limitations.

### **保修范围:**

1. 自购买之日起，产品主体在 1 年内，产品在正常使用情况下出现非人为的性能故障。
2. 无擅自拆机、无擅自改装或加装产品、其它非人为引起的故障。
3. 可提供保修服务凭证：保修卡，正规发票，单据或购买截图。

### **以下情况不在保修范围内：**

1. 不能提供正规购买凭证和填写详细信息的保修卡。
  2. 人为或不可抗因素造成的损害。
- 更多保修细则以售后政策为准：<https://www.feiyu-tech.cn/support>
- \* 本公司保留对上述售后条款和限制进行最终解释的权利。

QUALIFIED CERTIFICATE 合格证	Checker 检验员 _____ Production Date 生产日期 _____
---------------------------------	---







This document is subject to change without notice. If you have any questions about this document, please contact us by the following ways.

说明书内容如有更新，恕不另行通知。如对本内容有任何疑问或建议，可通过以下方式联系我们。

Dieses Dokument kann ohne vorherige Ankündigung geändert werden. Wenn Sie Fragen zu dies.

Le contenu du manuel peut être modifié sans préavis. Si vous avez des questions sur ce manuel, veuillez nous contacter.

Este manual está sujeto a cambios sin previo aviso. Si tiene alguna pregunta sobre este manual, comuníquese con nosotros de las siguientes maneras

Il contenuto del manuale è soggetto ad aggiornamenti senza preavviso. Se avete domande o suggerimenti su questo contenuto, potete contattarci attraverso i seguenti modi.

---

Manufactured by/Hergestellt von/Fabricant/Fabricado por/Produttore:

Guilin Feiyu Technology Incorporated Company

制造商：桂林飞宇科技股份有限公司

---

Website: [www.feiyu-tech.com](http://www.feiyu-tech.com)

Tel: +86 773-2320865 400-990-6118 (Only for mainland China 仅限大陆地区拨打)

E-mail: [support@feiyu-tech.com](mailto:support@feiyu-tech.com)