



# HAND BLENDER XM-71

Professional immersion blender. 750 W.



- ✓ Ergo-design & bi-mat-grip: external casing made in two materials for an ergonomic hold. Anti-slip grip. Optimum inclination of handle, minimising fatigue.
- ✓ Click-on-arm: detachable arm with fast and secure closure.
- ✓ Hood designed to avoid splashes.
- ✓ Intuitive use: very simple operation. LED warning light in two colours to indicate the status of the machine.
- ✓ Possibility of continuous operation.

### Built to last

- ✓ Professional performance: capable of carrying out prolonged work without the casing overheating.
- ✓ Life-plus: equipped with a motor which has passed all of the most demanding usage tests.
- ✓ Studied geometry: casing designed to avoid rolling and falling.
- ✓ Easy to clean: detachable arm, can be cleaned under the tap.
- ✓ Approved by NSF: guaranteed safety and hygiene.



### INCLUDES

- ✓ Fixed speed motor block.
- ✓ MA-71 mixer arm.

### ACCESSORIES

- MA-72 mixer arm.

### SALES DESCRIPTION

Fixed speed motor block.  
540 mm detachable arm.  
Designed for continuous use in recipients of up to 200 litres.

### All-in-one

- ✓ Professional hand blender designed for carrying out different preparations without the need for add-on tools.
- ✓ Professional Y-blade, made from tempered steel and with a long-duration cutting edge.
- ✓ Fixed speed.
- ✓ Designed to work in recipients of up to 200 litres.

### Maximum comfort for the user

- ✓ Logical and manageable size.



SAMMIC, S.L.  
Basarico, 1 - 20720 ASK011TA  
www.sammic.com



**www.sammic.co.uk**  
Food Service Equipment Manufacturer  
Unit 2, Trevanah Road  
Troon Industrial Park  
LE4 9LS - Leicester  
uksales@sammic.com  
Tel.: +44 0116 246 1900



Project	Date
Item	Qty
Approved	

DYNAMIC PREPARATION  
COMMERCIAL HAND BLENDERS - XM RANGE

product sheet  
updated 03/08/2020



# HAND BLENDER XM-71

Professional immersion blender. 750 W.



## SPECIFICATIONS

Total loading: 750 W  
Maximum recipient capacity: 200 l  
Motor speed: 12000 rpm  
Blade diameter: 70 mm  
Blade guard diameter: 123.3 mm

### Length

Liquidising arm length: 540 mm  
Total length: 880 mm

Net weight: 5 Kg  
Noise level (1m.): <80 dB(A)

### Crated dimensions

692 x 310 x 130 mm  
Gross weight: 5.41 Kg.

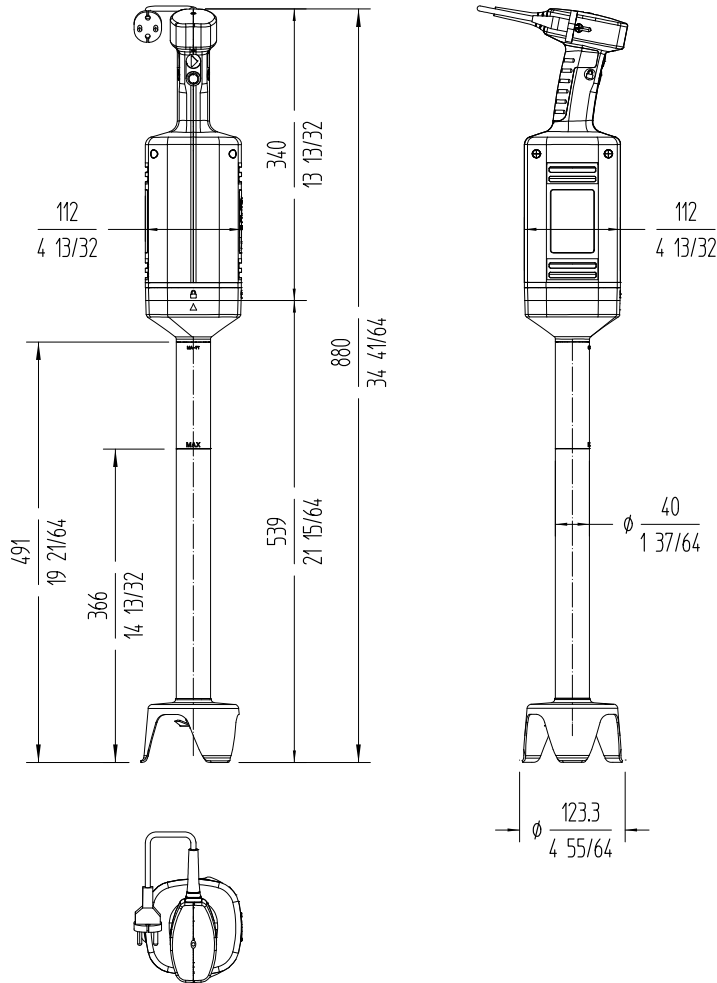

DYNAMIC PREPARATION  
COMMERCIAL HAND BLENDERS - XM RANGE

## AVAILABLE MODELS

3030849 Hand blender XM-71 230/50-60/1

\* Ask for special versions availability



[www.sammic.co.uk](http://www.sammic.co.uk)

Food Service Equipment Manufacturer

Unit 2, Trevanah Road  
Troon Industrial Park  
LE4 9LS - Leicester

[uksales@sammic.com](mailto:uksales@sammic.com)  
Tel.: +44 0116 246 1900



Project

Date

Item

Qty

Approved

product sheet  
updated 03/08/2020