



HAND BLENDER XM-12

Compact immersion blender.



machine is connected to the mains.

Designed to last

- ✓ Professional performance: it is capable of carrying out prolonged work without overheating.
- ✓ Life-plus: equipped with a motor which has passed all of the most demanding usage tests.
- ✓ Studied geometry: casing designed to avoid rolling and falling.
- ✓ Easy to clean: the arm can be washed under the tap or in the dishwasher.
- ✓ Approved by NSF: guaranteed safety and hygiene.

INCLUDES

- ✓ Variable speed motor block.
- ✓ MA-12 mixer arm.

ACCESSORIES

- Mixer arms MA-10

SALES DESCRIPTION

The most delicate preparations, airy blendings, smooth purees with no need of add-on tools.
 Designed for continuous use.
 Ideal for mise en place.
 Maximum comfort of use in recipients of up to 10 litres.

All-in-one

- ✓ Versatility without add-on tools.
- ✓ Tri-blade, professional, made of tempered steel and equipped with a long lasting cutting edge.
- ✓ Vario-speed: adjustable speed.
- ✓ Ideal for mise-en-place and support in service.
- ✓ Designed to work with maximum comfort in recipients of up to 10 litres of capacity.
- ✓ In option: shorter MA-11 mixarm.

Maximum comfort for the user

- ✓ Compact design: logical and manageable size.
- ✓ Ergo-design & bi-mat-grip: The external casing, in two materials, allows an ergonomic hold with an anti-slip grip and the handle features optimum inclination to minimise fatigue.
- ✓ Click-on-arm: detachable arm with quick and safe locking.
- ✓ Hood designed to avoid splashes during work.
- ✓ Intuitive use: very simple operation. Includes warning light when the



SAMMIC, S.L.
 Basiglio, 1 - 20720 ASK011TA
 www.sammic.com



www.sammic.co.uk

Food Service Equipment Manufacturer

Unit 2, Trevanth Road
 Troon Industrial Park
 LE4 9LS - Leicester

uksales@sammic.com
 Tel.: +44 0116 246 1900



Project	Date
Item	Qty
Approved	

DYNAMIC PREPARATION
 COMMERCIAL HAND BLENDERS - XM RANGE

product sheet
 updated 29/03/2021



HAND BLENDER XM-12

Compact immersion blender.



SPECIFICATIONS

Total loading: 240 W
 Maximum recipient capacity: 10 l
 : 148.6 mm
 Motor speed: 1500 - 15000 rpm
 Blade diameter: 44 mm
 Blade guard diameter: 65 mm

Length

Liquidising arm length: 223 mm
 Total length: 448 mm

Net weight: 1.51 Kg
 Noise level (1m.): <80 dB(A)

Crated dimensions

496 x 80 x 180 mm
 Gross weight: 1.94 Kg.

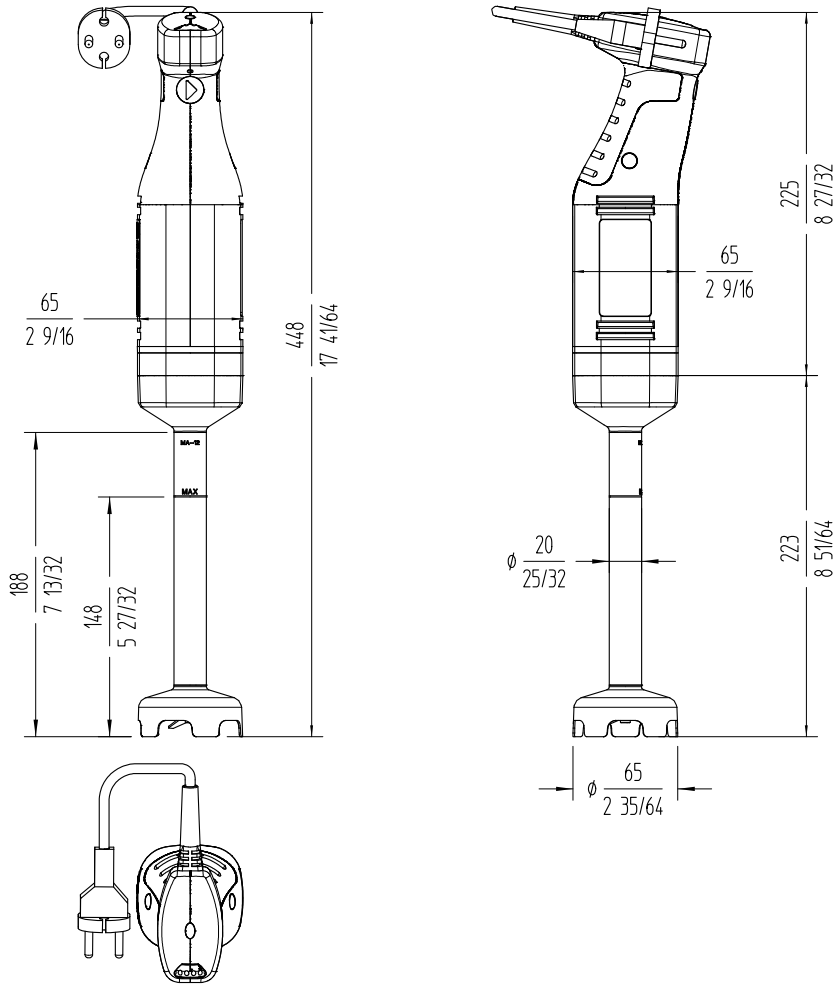

AVAILABLE MODELS

3030736 Hand blender XM-12 230/50-60/1

* Ask for special versions availability



www.sammic.co.uk
 Food Service Equipment Manufacturer
 Unit 2, Trevanth Road
 Troon Industrial Park
 LE4 9LS - Leicester
 uksales@sammic.com
 Tel.: +44 0116 246 1900



Project	Date
Item	Qty
Approved	

DYNAMIC PREPARATION
 COMMERCIAL HAND BLENDERS - XM RANGE

product sheet
 updated 29/03/2021