



# FOOD-PROCESSOR - EMULSIFIER KE-4V

Compact bowl cutter & emulsifier. Adjustable speed with brushless technology.



- tion of the cutting edges.
- ✓ Depending on the purpose, the possibility of using optional smooth or perforated blades.
- ✓ Special programmes: thick and fine grinding.
- ✓ Possibility of extending its functionality by adding the vegetable slicer attachment.

### Built to last

- ✓ Sturdy construction in food-grade best quality materials.

### Maximum comfort for the user

- ✓ Cutter bowl equipped with ergonomic handle.
- ✓ Advanced control panel that is very intuitive to use and offers all the information at a glance.
- ✓ Control panel equipped with timer to standardise processes.

### Maintenance, safety, hygiene

- ✓ Safety microswitches in the position of the bowl and the lid.
- ✓ Complete error warning system.
- ✓ Appliance certified by NSF International (regulations on hygiene, cleaning and materials suitable for contact with foods).
- ✓ 100% tested.

Please note: NSF listing in process (March 2021).

## SALES DESCRIPTION

Compact ULTRA line. Variable speed motor block + 4,4 l cutter bowl.

### Equipped with “brushless” technology: powerful and efficient motors.

- ✓ Maximum efficiency: maintain the torque throughout the speed range.
- ✓ Exclusive “force control system”: guarantee of a uniform and high quality result.
- ✓ Lightweight and compact design: they weigh less, they occupy less space.
- ✓ Improved air/water-tightness since no ventilation is required.
- ✓ They generate less noise: improved workplace environment.

### Efficiency and performance.

- ✓ Possibility of programming by time and pulse button.
- ✓ 4.4 lt-bowl equipped with lateral stirrer and high shaft to obtain a bigger production.
- ✓ Transparent polycarbonate lid equipped with hole to add ingredients in use.
- ✓ Lid complete with gasket to avoid product overflowing.
- ✓ Homogeneous and fine mixing result thanks to the lateral stirrers and inverted blade.
- ✓ The lateral stirrers avoid product overheating.
- ✓ Very uniform finish due to the movement generated the special posi-

## INCLUDES

- ✓ Variable speed motor block.
- ✓ Cutter bowl with toothed blades.

## ACCESSORIES

- Hub with smooth blades.
- Vegetable slicer attachment.
- Hub with perforated blades.



[www.sammic.co.uk](http://www.sammic.co.uk)

Food Service Equipment Manufacturer

Unit 2, Trevanah Road  
Troon Industrial Park  
LE4 9LS - Leicester

[uksales@sammic.com](mailto:uksales@sammic.com)  
Tel.: +44 0116 246 1900



Project

Date

Item

Qty

Approved



# FOOD-PROCESSOR - EMULSIFIER KE-4V

Compact bowl cutter & emulsifier. Adjustable speed with brushless technology.



## SPECIFICATIONS

Bowl capacity: 4.4 l  
 Max. product capacity: 2.5 Kg.  
 Maximum capacity (liquid): 2.4 l  
 Bowl dimensions: Ø193 mm x 161 mm  
 Total loading: 1100 W  
 Speed, min-max: 300 rpm - 3000 rpm

### External dimensions (WxDxH)

- ✓ Width: 252 mm
  - ✓ Depth: 309 mm
  - ✓ Height: 434 mm
- Net weight: 11.9 Kg

### Crated dimensions

285 x 385 x 695 mm  
 Volume Packed: 0.08 m<sup>3</sup>  
 Gross weight: 15.5 Kg.

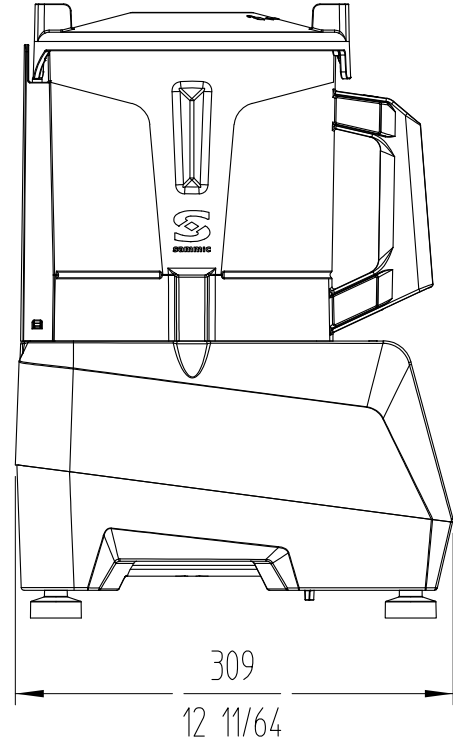
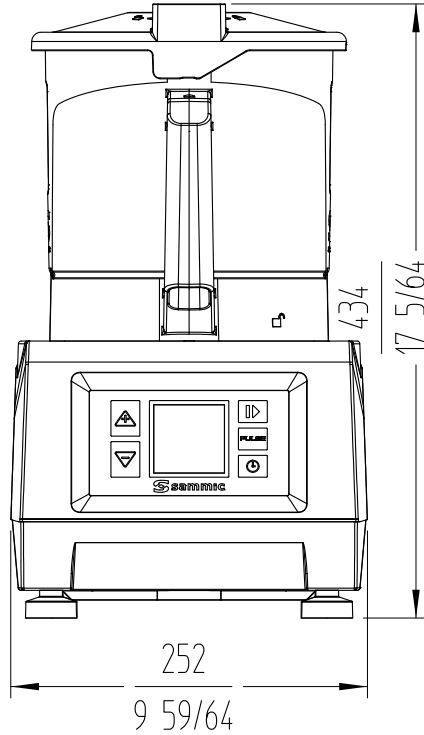

DYNAMIC PREPARATION  
CUTTER-MIXERS & EMULSIFIERS

## AVAILABLE MODELS

-----

\* Ask for special versions availability

 <p><b>www.sammic.co.uk</b>          Food Service Equipment Manufacturer          Unit 2, Trevanah Road          Troon Industrial Park          LE4 9LS - Leicester          uksales@sammic.com          Tel.: +44 0116 246 1900</p> 	Project	Date
	Item	Qty
	Approved	

product sheet  
updated 25/02/2021