



FOOD-PROCESSOR K-41

Compact bowl cutter. 1 speed.



- ✓ The electronic command panel is very intuitive.

Maintenance, safety, hygiene

- ✓ Safety microswitches in the position of the bowl and the lid.
- ✓ Complete error warning system.
- ✓ Appliance certified by NSF International (regulations on hygiene, cleaning and materials suitable for contact with foods).
- ✓ 100% tested.

Please note: NSF listing in process (March 2021).

INCLUDES

- ✓ 1-speed motor block.
- ✓ Cutter bowl with toothed blades.

ACCESSORIES

- Hub with smooth blades.
- Vegetable slicer attachment.
- Hub with perforated blades.

SALES DESCRIPTION

Compact ACTIVE line. 1-speed motor block + 4,4 l cutter bowl.

Efficiency and performance.

- ✓ 4.4 lt-bowl equipped with lateral stirrer and high shaft to obtain a bigger production.
- ✓ Transparent polycarbonate lid equipped with hole to add ingredients in use.
- ✓ Lid complete with gasket to avoid product overflowing.
- ✓ Homogeneous and fine mixing result thanks to the lateral stirrers and invert-blade technology.
- ✓ The lateral stirrers avoid product overheating.
- ✓ Very uniform finish due to the movement generated the special position of the cutting edges.
- ✓ Depending on the purpose, the possibility of using optional smooth or perforated blades.
- ✓ Possibility of extending its functionality by adding the vegetable slicer attachment.

Built to last

- ✓ Sturdy construction in food-grade best quality materials.
- ✓ High power asynchronous motor.

Maximum comfort for the user

- ✓ Cutter bowl equipped with ergonomic handle.



SAMMIC, S.L.
Basiglio, 1 - 20720 ASK011TA
www.sammic.com

www.sammic.co.uk

Food Service Equipment Manufacturer

Unit 2, Trevanah Road
Troon Industrial Park
LE4 9LS - Leicester

uksales@sammic.com
Tel.: +44 0116 246 1900



Project	Date
Item	Qty
Approved	



FOOD-PROCESSOR K-41

Compact bowl cutter. 1 speed.



SPECIFICATIONS

Bowl capacity: 4.4 l
 Max. product capacity: 2.5 Kg.
 Maximum capacity (liquid): 2.4 l
 Bowl dimensions: Ø193 mm x 161 mm
 Total loading: 800 W
 Speed, min-max: 1500 rpm

External dimensions (WxDxH)

- ✓ Width: 252 mm
 - ✓ Depth: 309 mm
 - ✓ Height: 434 mm
- Net weight: 14.2 Kg

Crated dimensions

285 x 385 x 695 mm
 Volume Packed: 0.08 m³
 Gross weight: 18 Kg.

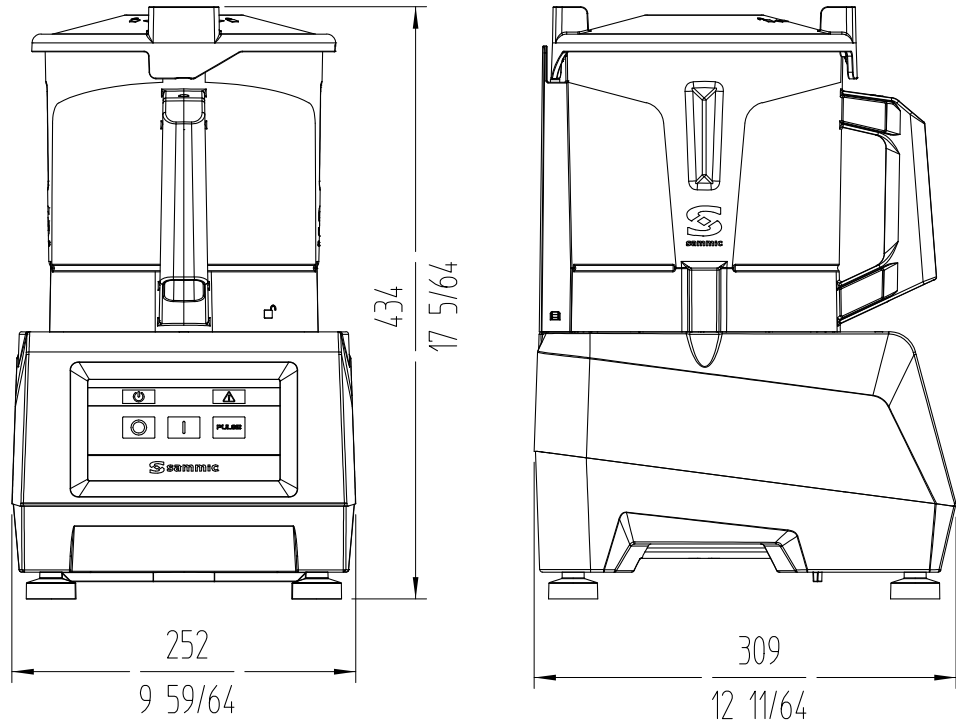

DYNAMIC PREPARATION
 CUTTER-MIXERS & EMULSIFIERS

AVAILABLE MODELS

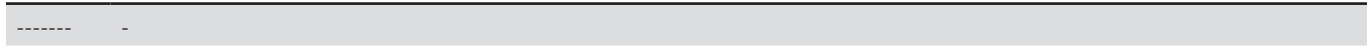

* Ask for special versions availability

 <p>www.sammic.co.uk Food Service Equipment Manufacturer Unit 2, Trevanth Road Troon Industrial Park LE4 9LS - Leicester uksales@sammic.com Tel.: +44 0116 246 1900</p> 	Project	Date
	Item	Qty
	Approved	

product sheet
 updated 25/02/2021