



VEGETABLE PREPARATION MACHINE CA-31

Vegetable preparation machine. Production up to 450 kg/hour.



SALES DESCRIPTION

Single-speed motor block + Regular hopper.

FEATURES AND BENEFITS

A perfect cut

- ✓ High precision adjustments to obtain a uniform and excellent-quality cut.
- ✓ It can be fitted with a wide range of discs and grids of the highest cutting quality. Combining these accessories together to obtain more than 70 different types of cuts and grating grades.

Built to last

- ✓ Made from stainless steel and food-grade materials of the highest quality: stainless steel motor block and food-grade aluminium head.
- ✓ High power asynchronous motor.

Maximum comfort for the user

- ✓ Ergonomic design: product sliced in one single movement.
- ✓ Lateral product output: requires less space on the worktop and guides the product, avoiding splashes.
- ✓ The electronic command panel is very intuitive.

Maintenance, safety, hygiene

- ✓ Lever and lid easily removable for cleaning purposes.
- ✓ Combination of safety systems: head, cover, power switch.
- ✓ Appliance certified by NSF International (regulations on hygiene, cleaning and materials suitable for contact with foods).
- ✓ 100% tested.

INCLUDES

- ✓ Single-speed motor block.
- ✓ Regular hopper.

ACCESSORIES

- FCC Curved Slicing Discs
- FCO Rippled Slicing Discs
- FFC Chipping Grids
- FMC Dicing Grids
- FCE Julienne Discs
- FR Shredding & Grating Discs
- Long vegetable attachment
- Disc and Grid Holder Device
- Stand-trolley
- Grid Cleaning Kit
- FC-D Slicing Discs
- SH Shredding & Grating Discs



www.sammic.co.uk

Food Service Equipment Manufacturer

Unit 2, Trevanah Road
Troon Industrial Park
LE4 9LS - Leicester

uksales@sammic.com
Tel.: +44 0116 246 1900



Project

Date

Item

Qty

Approved

DYNAMIC PREPARATION
COMMERCIAL VEGETABLE PREPARATION MACHINES

product sheet
updated 28/10/2019



VEGETABLE PREPARATION MACHINE CA-31

Vegetable preparation machine. Production up to 450 kg/hour.



SPECIFICATIONS

Hourly production: 150 Kg - 450 Kg

Inlet opening: 136 cm²

Disc diameter: 205 mm

Motor speed: 365 rpm

Loading

Single Phase: 550 W

Three phase: 370 W

Noise level (1m.): <70 dB(A)

Background noise: 32 dB(A)

External dimensions (WxDxH)

Width: 389 mm

Depth: 405 mm

Height: 544 mm

Net weight: 21 Kg

Crated dimensions

435 x 430 x 600 mm

Volume Packed: 0.11 m³

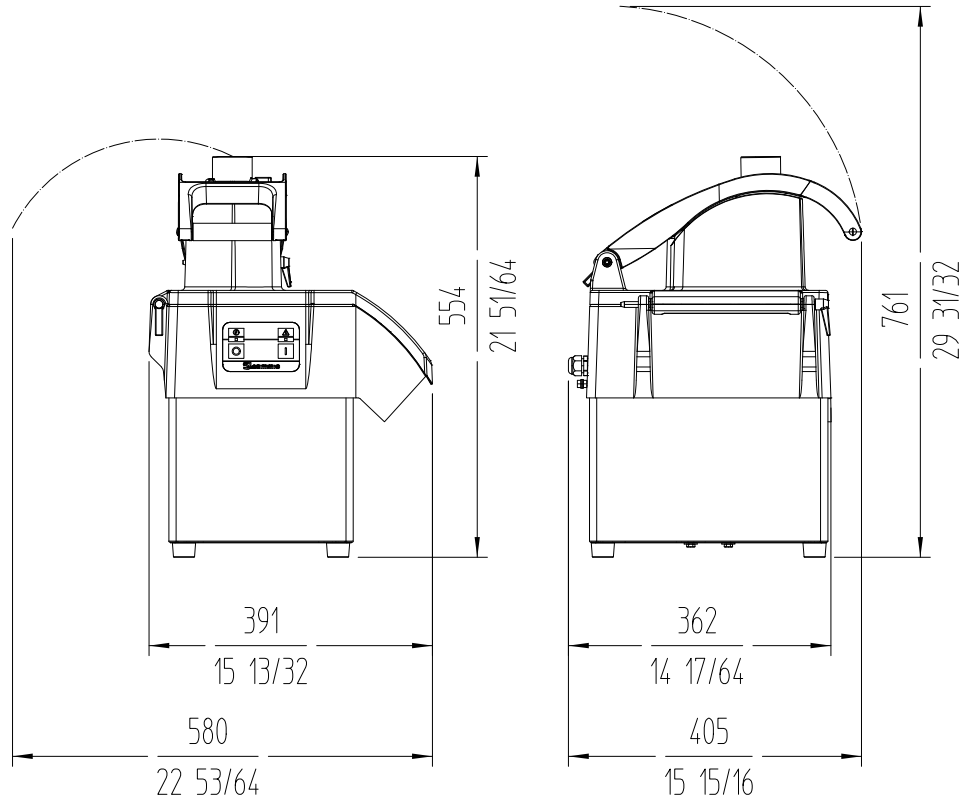

DYNAMIC PREPARATION
COMMERCIAL VEGETABLE PREPARATION MACHINES

AVAILABLE MODELS

- 1050700 Vegetable preparation machine CA-31 230/50/1
- 1050701 Vegetable preparation machine CA-31 230-400/50/3N
- 1050705 Vegetable preparation machine CA-31 220/60/1
- 1050707 Vegetable preparation machine CA-31 220-380/60/3N
- 1050712 Vegetable preparation machine CA-31 230/50/1 UK

* Ask for special versions availability



www.sammic.co.uk

Food Service Equipment Manufacturer

Unit 2, Trevanth Road
Troon Industrial Park
LE4 9LS - Leicester

uksales@sammic.com
Tel.: +44 0116 246 1900



Project	Date
Item	Qty
Approved	

product sheet
updated 28/10/2019