

**Model**

SP-100

**Product Description**

Mixer, 9.5 litre, Heavy Duty

**Product Code**

5M221

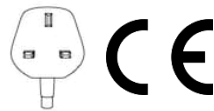
**Standard Features**

- Heavy duty bench mounted, gear driven planetary mixer with a powerful 3-speed transmission
- Bowl capacity of 10 Quarts (9.5ltr)
- Fully CE approved with an electrically interlocked bowl guard and bowl lift
- Particularly suitable for bakeries, hotels, restaurants, canteens etc
- Quiet operation
- Permanently lubricated transmission
- Thermal overload protection (No-volt release)
- Resettable thermal overload
- Abrasion resistant transmission design
- Stainless steel revolving safety guard with ingredient chute
- Heat treated hardened steel alloy gears, 25% thicker than the industry leader
- Front mounted controls for easy access and operation
- Industry standard #12 attachment hub
- Non-slip rubber feet
- High torque transmission for heavy loads
- Emergency Stop
- 6-foot cord and plug
- Optional voltages and frequencies available upon request

**Standard Accessories / Attachments**

- 1 x Whisk
- 1 x Beater
- 1 x Dough Hook
- 1 x 9.5 litre bowl

**Warranty**

Covered by Metcalfe 3-year warranty (1<sup>st</sup> year parts and labour, 2<sup>nd</sup> & 3<sup>rd</sup> years parts only) and full after sales service

## Optional Accessories / Attachments

Item	Product Code
Spare Bowl	SP100B02
Beater	SP100B01
Whisk	SP100W01
Dough Hook	SP100D01

Item	Product Code
Stand	5M225
Mobile Trolley	5M226

Item	Product Code
Veg Prep Attachment (V99S)	SPV01
Mincer Attachment (VH-12)	SPM01

Additional extrusion plates and cutting blades are available for both the VH12 & V99S attachments, please refer to their specification sheets for further details.

## Drawings

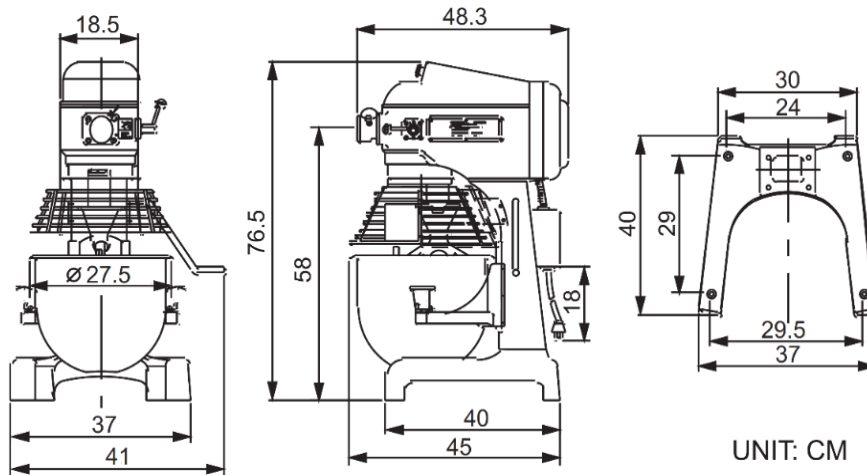

## Specifications

Model	Capacity (ltr)	Phase ( $\varnothing$ )	Motor (Volt)	Frequency (Hz)	Power (kW) / (hp)	Speed (rpm)	Hub (rpm)
SP-100	9.5	1	220	50	0.25 / 0.33	106, 196 and 358	106, 196 and 358

## Dimensions | Shipping Information

Model	Overall Dimensions (D x W x H)	Net Weight (kg)	Packed Dimensions (D x W x H)	Packed Weight (kg)	Volume (m3)
SP-100	450 x 410 x 765	78	560 x 455 x 960	87	0.24

We reserve the right to alter the specification and technical details for this item at anytime without prior notice.

©Metcalfe Catering Equipment Ltd

Metcalfe Catering Equipment Ltd  
 Haygarth Park  
 Blaenau Ffestiniog  
 Gwynedd  
 LL41 3PF  
 Tel: 01766 830 456 | Fax: 01766 831 170  
 E-mail: sales@metcalfecatering.com

View our current catalogue visit:  
[www.metcalfecatering.com/brochure](http://www.metcalfecatering.com/brochure)

Or scan the QR code

