



# Installation, Operating and Servicing Instructions

## Opus 800 Electric Clam Griddle OE8210, OE8211

Please make a note of your product details for  
future use:

Date Purchased: \_\_\_\_\_

Model Number: \_\_\_\_\_

Serial Number: \_\_\_\_\_

Dealer: \_\_\_\_\_

\_\_\_\_\_

*Opus* **800**

# CONTENTS

Important Information	2
Warnings and Precautions	3
Technical Data	3
Checklist of Enclosures	4
Installation and Commissioning	4-5
Operating Instructions	6-7
Cleaning	7
Servicing, Maintenance and Component Replacement	7-9
Fault Finding	9
Spare Parts List	9
Accessories	10
Service Information and Guarantee	11

## IMPORTANT INFORMATION

---



Read these instructions carefully before using this product, paying particular attention to all sections that carry warning symbols, caution symbols and notices. Ensure that these are understood at all times.

---



### **WARNING!**

This symbol is used whenever there is a risk of personal injury.

---



### **CAUTION!**

This symbol is used whenever there is a risk of damaging your Lincat product.

---



### **NOTE:**

This symbol is used to provide additional information, hints and tips.

---

**KEEP THIS MANUAL FOR FUTURE REFERENCE**

## WARNINGS AND PRECAUTIONS



This appliance must be installed, commissioned and serviced by a qualified person in accordance with national and local regulations in force in the country of installation.

If the supply cord is damaged, it must be replaced by the manufacturer, its service agent or similarly qualified person.

Ensure that the plug/socket is accessible at all times.

Strip plastic coating and clean the appliance before use.

During operation parts may become hot - avoid accidental contact.

Disconnect this appliance before servicing, maintenance or cleaning.

## TECHNICAL DATA

	OE8210	OE8211
Height (mm)	640	
Width (mm)	800	400
Depth, excluding handles(mm)	800	
Weight (kg)	160	85
Griddle cooking area WxD (mm)	766x525	366x525
Clam griddle cooking area WxD (mm)	330x500	
Electricity supply requirements	3N~+E	3N~E
	6.5kW	3.25kW
3N~(three phase supply)	6.5kW	3.25kW
	4.2kW	2.1kW
Voltage 3N~Amps 3N~	400V	400V
	L1 – 28.0	L1 – 14.0
	L2 – 28.0	L2 – 14.0
	L3 – 18.0	L3 – 9.0
Total amps	74A	37A
Total power rating	17.2kW	8.6kW

## CHECK LIST OF ENCLOSURES

Warranty card
Instructions manual
Scraper
Teflon sheets (1 per head)

# INSTALLATION AND COMMISSIONING

This product is heavy; prior to installation a handling assessment should be made.

This appliance must be earthed. An equipotential bonding terminal is provided to allow cross bonding with other equipment.



Means of isolation with at least 3mm contact separation in all poles must be incorporated into the fixed wiring of this appliance.

The fixed wiring insulation must be protected by insulated sleeving having a temperature rating of at least 60 Deg C.

Supply cords shall be oil resistant, sheathed flexible cable not lighter than ordinary polychloroprene or equivalent elastomer sheathed cord (code 60245 IEC 57)

Install this appliance beneath an extraction canopy.

If using a stand fitted with castors, use caution at all times when manipulating or moving, and lock castors when appliance is in position.

Install this appliance on a level surface ensuring all vents are unobstructed. Any partitions, walls or furniture must be of non-combustible material (see Fig 1). Minimum distances A 100mm B 1000mm.

## Electrical connection

The electrical supply cable enters the unit through a cable gland in the rear panel. Connection of the electrical supply cable is to a terminal block behind the fascia panel. The terminal block has a metal cover retained by two screws.

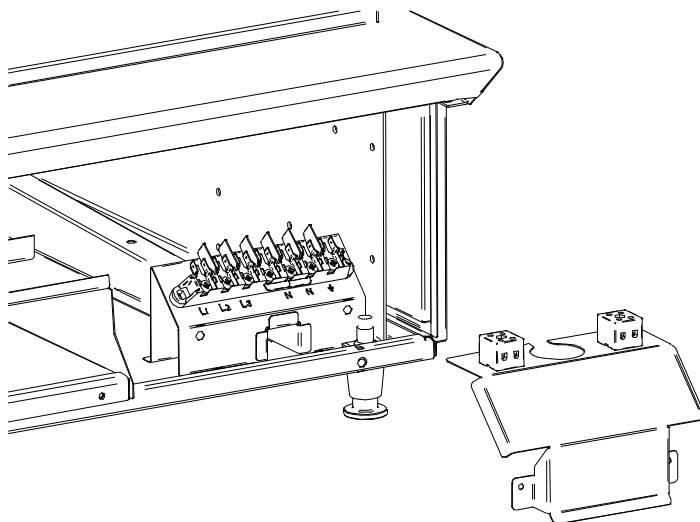

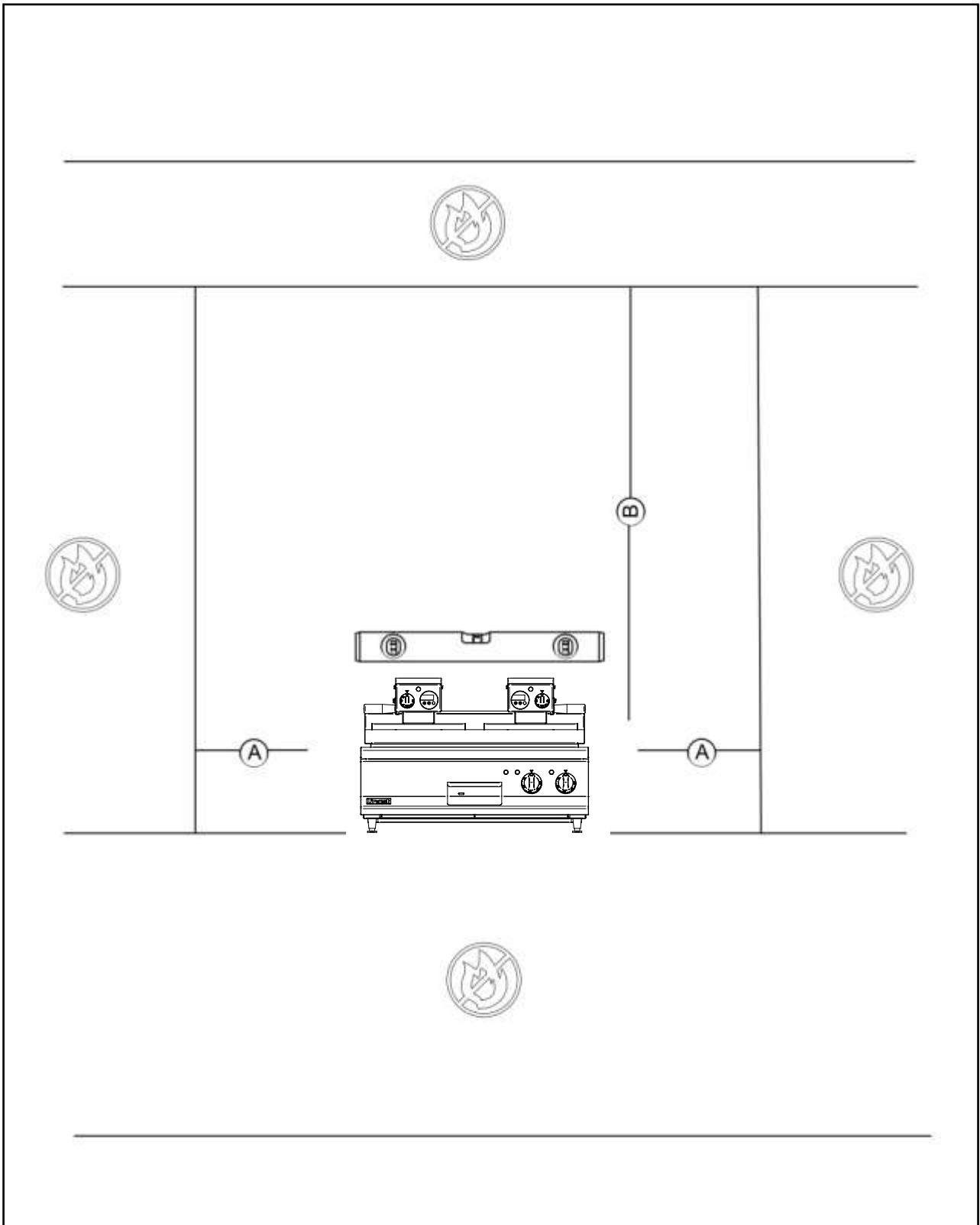

Fig 1

# OPERATING INSTRUCTIONS

## Griddle plate preparation

Before using the appliance for the first time, wipe off protective oil from the griddle plates and wash down with a warm detergent solution.

Griddle plate (stainless steel): Coat with a light film of cooking oil

Clam plate (Aluminium): Fit the Teflon sheets to the clam plate before cooking.  
**Do not use the appliance without the Teflon sheets fitted.**

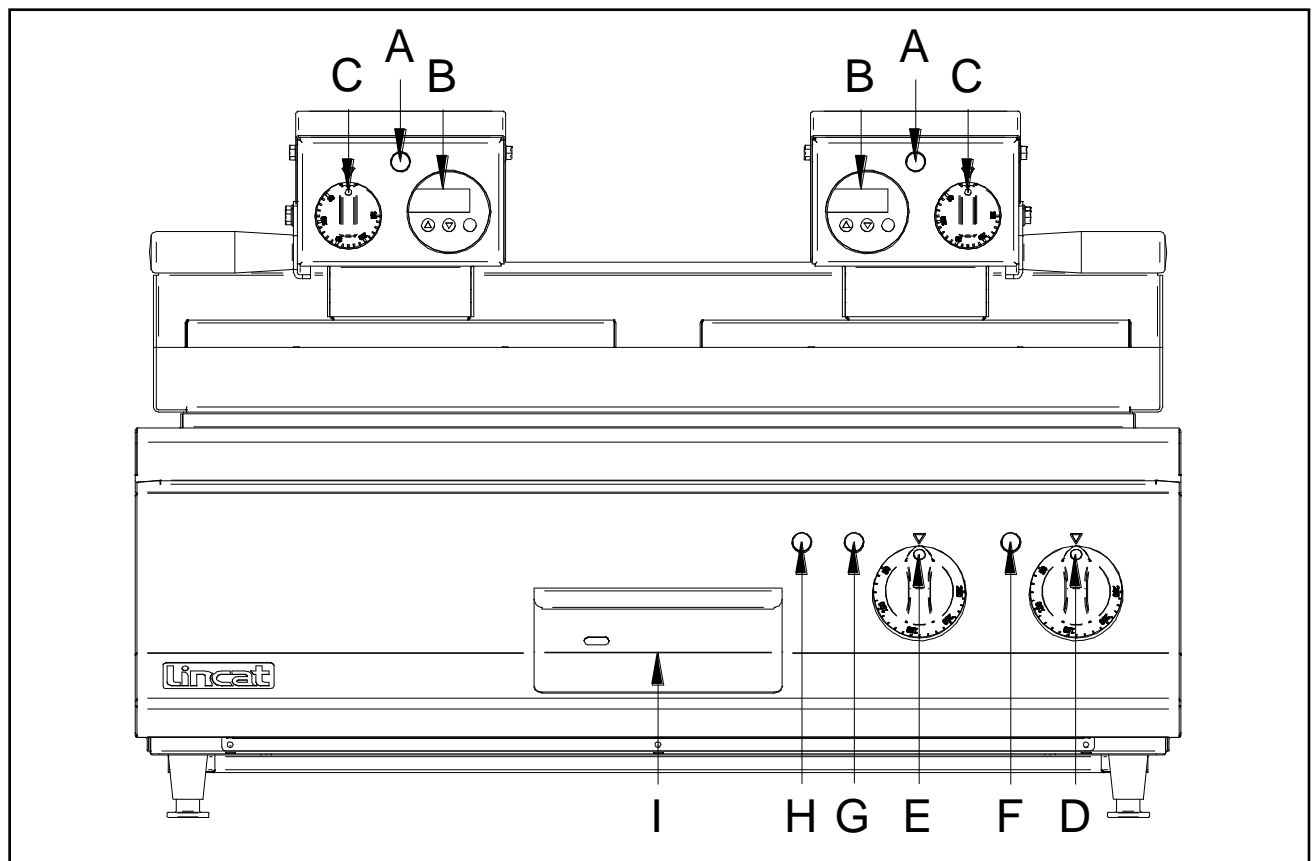

Fig 2

- A – Amber neon clam head
- B – Digital timer
- C – Clam control knob
- D – Base Control RH side
- E – Base Control LH side
- F – Amber neon base RH side
- G – Amber neon base LH side
- H – Green Neon mains power
- I – Fat collection drawer

Only qualified or trained personnel should use this appliance.

Note: The OE8210 griddle plate is separated into two equal heat zones, each with an individual control.

## Switching on

Refer to Fig 2. Turn on the power supply at the isolating switch; the green neon illuminates indicating power to the appliance. Turn the relevant thermostat control knobs to the required temperature; the associated amber neon's will illuminate. When the griddle plates reach the selected temperature, the amber neons extinguish and cooking may begin.

## Shutting down

Turn all the control knobs to the 'Off' position and switch off at the isolating socket. Be aware that the appliance will remain hot for some time.

# CLEANING

Your Lincat product has a manufacturer's warranty. This requires you to maintain and care for your product and follow maintenance instructions. If you fail to maintain your unit or damage components Lincat may charge you for a warranty repair. Please check the website for terms and conditions.



Do not use a water jet or steam cleaner, and do not immerse this appliance.

Clean all panels with warm water and mild detergent, do not use abrasive materials or cleaners containing chlorine. Dry with a soft cloth.

Empty and clean the fat collection drawer regularly.

### Griddle plate cleaning

Stainless steel griddle plate – scrape off any food residue and wash down with mild detergent and water. Rinse thoroughly to remove any traces of detergent, and dry.

Aluminium clam plate – Remove and clean Teflon sheets. Wash aluminium plate if necessary with mild detergent and water. Rinse to remove traces of detergent and dry. Cover with new or cleaned Teflon sheet. Do not use a scraper or abrasive cleaners on the aluminium plate.

# SERVICING, MAINTENANCE AND COMPONENT REPLACEMENT

All servicing, maintenance and component replacement on this appliance should be carried out by one of our recommended service engineers.

## **Neon replacement**

Remove the screws beneath the fascia panel, and remove the fascia panel by rotating the bottom forward.

Remove the cables from the neon. Unscrew the neon retaining nut to remove the neon.

Reverse the sequence to fit new neon and reassemble.

Note: Remove top cover of clam when replacing clam neon, and follow sequence as above.

## **Thermostat replacement**

### **On the griddle plate:**

Remove the screws beneath the fascia panel, and remove the fascia panel by rotating the bottom forward.

Remove the control knob and undo the screws that hold the thermostat. Remove the cables from the thermostat, noting their location.

Remove the screws that hold the bulb bracket and withdraw from the element cartridge. Discard the failed thermostat.

Reverse the procedure to fit the new thermostat, ensuring that the capillary is formed at a radius of at least 4mm and is free of kinks.

### **On the clam plate:**

Remove the top panel of the clam top and disconnect the cables from the thermostat, noting their location.

Remove the cover plate and release the rubber grommet from inside the head to allow access to the stat bracket fixing screws.

Remove the bracket and remove the stat.

Remove the control knob and the screws holding the thermostat to the clam fascia.

Fit new thermostat by reversal of the above procedure. Do not damage the capillary.

Ensure the stat bracket is not in direct contact with any part of the element sheath.

## **Element Replacement**

### **On the griddle plate:**

Remove the screws beneath the fascia panel, and remove the fascia panel by rotating the bottom forward.



Disconnect the element cables from the terminal block, noting their location.

Remove the stat bracket containing the stat bulb from the element cartridge.

The elements are contained in a cartridge unscrew the M6 nuts of the cartridge strap, this will allow the cartridge to drop down at the front.

Remove the element cartridge and fit the replacement, locating carefully reposition the cartridge beneath the griddle plate and tighten up the cartridge strap.

Fit stat bracket and fascia by reversal of the above procedure.

### **On the clam plate:**

Remove the top panel of the clam arm and disconnect the element cables from the terminal block, noting their location.

Remove the cover plate and release the rubber grommet from inside the head to allow access to the stat bracket fixing screws and remove.

Remove the stat from the bracket.

Release the compression of the springs by backing off the adjustment nuts, firstly making a note of the adjustment nuts position and lifting action ready for reassembly.

Undo the fixing screws (x8) that attach the cover from the top plate and inner frame.

Lift the arm body allowing access to the element cartridge and replace with new.

Reverse the sequence to fit new element cartridge and reassemble.

Note: Adjust the compression springs during reassembly to give the correct lifting action.

## **FAULT FINDING**

Please refer to the Service Help Desk number on the final page of this manual.

## SPARE PARTS LIST

Part Number	Description
EL306	Element
HA05	Handle – clam top
KN245	Control knob – clam top
KN509	Control knob – griddle
LE38	Leg
NE46	Green neon
NE47	Amber neon
SC01	Scraper
TH110	Control thermostat
TI40	Digital timer

## ACCESSORIES

Part Number	Description	Used on
OA8921	Floor stand	OE8211
OA8956	Floor stand	OE8210
OA8971	Pedestal with doors	OE8211
OA8974	Pedestal with doors	OE8210
OA8960	Plate height adjuster	All (Per plate)
TFS01	PTFE non-stick sheet	All

## SERVICE INFORMATION

For help with the installation, maintenance and use of your **Lincat** equipment, please contact our service department:

**☎ UK: 01522 875520**

For non-UK customers, please contact your local Lincat dealer

All service work, other than routine cleaning should be carried out by one of our authorised service agents. We cannot accept responsibility for work carried out by other persons.

To ensure your service enquiry is handled as efficiently as possible, please tell us:

- Brief details of the problem
  - Product code
  - Type number
  - Serial number
- } All available on serial plate

Lincat reserve the right to carry out any work under warranty, given reasonable access to the appliance, during normal working hours, Monday to Friday, 08:30 to 17:00.

### GUARANTEE

This unit carries a comprehensive UK mainland 2 year warranty. The guarantee is in addition to, and does not diminish your statutory or legal rights.

The guarantee does not cover:

- Accidental damage, misuse or use not in accordance with the manufacturer's instructions
- Consumable items (such as filters, glass, bulbs, slot toaster elements and door seals.)
- Damage due to incorrect installation, modification, unauthorised service work or damage due to scale, food debris build-up, etc.

The manufacturer disclaims any liability for incidental, or consequential damages. Attendance is based on reasonable access to the appliance to allow the authorised technician to carry out the warranty work.

Service calls to equipment under warranty will be carried out in accordance with the conditions of sale. Unless otherwise specified, a maximum of 15 minutes of administrative time, not spent directly carrying out servicing work, is provided for within the warranty. Any requirement for staff attending the call to spend greater time than 15 minutes due to administrative requirements, such as on health and safety risk assessments, will be chargeable at the prevailing rate.

