

Overview

Our range of high quality cleaning, rinsing and polishing products will enable your kitchen staff to work quickly and productively, while improving hygiene standards still further.

Our latest spray units are designed to improve the efficiency of dishwashers; our wall, ceiling and floor mounted hose reels are ideal for all kitchen wash-up areas, while the Pot Boy cleaning system provides an extremely effective method of removing encrusted or burnt deposits from pans, cookware and ovens.

In addition, the IMC A4 Burnisher is a quick, simple and safe method of bringing the shine and sparkle back to silverware, helping to extend the life of silver cutlery and other silver table items.

Electrical Connection

All electrical work must be carried out by a qualified electrician in accordance with the IEE Codes of Practice.

Product Conformity

IMC cleaning, rinsing and polishing equipment conform to the Machine Safety Directive 89/392/EEC as amended by 91/368/EEC and 93/44/EEC and are manufactured under quality system BSEN ISO 9001:2000. They also conform to the protection requirements of the Electro Magnetic Compatibility Directive 89/336/EEC and are manufactured in accordance with harmonised standards EN 50-014-1 Generic Emission and EN 50-014-2 Generic Immunity (plus product specific standards). They also satisfy the essential requirements of the Low Voltage Directive 73/23/EEC amended by 93/68/EEC.

All IMC cleaning and rinsing equipment is WRAS approved and manufactured in accordance with standards BSEN 60335-1 and BSEN 60335-2-16.

Warranty

IMC cleaning, rinsing and polishing equipment come with one year parts and labour warranty (subject to usage and regular maintenance as laid down in the operation and installation manual).

Spare Parts

Spare parts are available for all major serviceable items. Please contact:

IMC service telephone:	+44 (0)1923 718017
IMC spares telephone:	+44 (0)1923 718018
Fax:	+44 (0)1923 896256
E-mail:	parts@imco.co.uk



Harvey Road
Croxley Green
Hertfordshire
WD3 3AX
United Kingdom

Tel: +44 (0)1923 718000
Fax: +44 (0)1923 777273
Email: cleaning@imco.co.uk
www.imc.co.uk

Specifications are subject to change without notice.

4CM/CLEANTS/0106UK



Technical Information Cleaning, Rinsing and Polishing



January 2006
(UK Version)

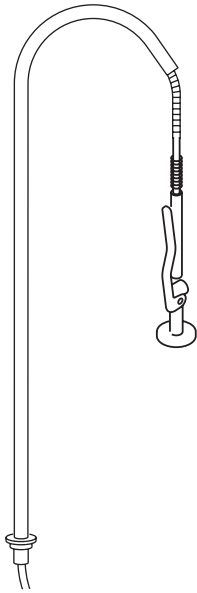

Pre-Rinse Sprays	
General	
Reach of hose	1.5m
Hose length	3m
Dimensions (h x d)	866mm x 340mm
Installation information	
Water connection	PR1-1/2" BSP F PR2 & PR3-15mm compression joint
Water feed	15mm copper pipe
Water pressure range	0.4 to 5 bar (4 to 50m head)
Water temperature	65°C (150°F) maximum
Fixings	Wall bracket adjustable 35mm - 180mm
Features	
	Lightweight heat insulated spray head
	Protective rubber bumper on spray head
	Stainless steel spirally wound covered hose
	Stainless steel vertical tube
	Wall bracket for vertical tube
Product code details	
F63/100	PR1 With water connection
F63/200	PR2 With single tap
F63/300	PR3 With mixer tap
O63/PRA11	Bracing Spray for island locations
Shipping specification	
Packing dimensions (h x w x d)	1220mm x 440mm x 80mm
Packing volume	0.042m ³
Packing weight (gross/net) PR1	5kg/4kg
Packing weight (gross/net) PR2	6kg/5kg
Packing weight (gross/net) PR3	7kg/6kg

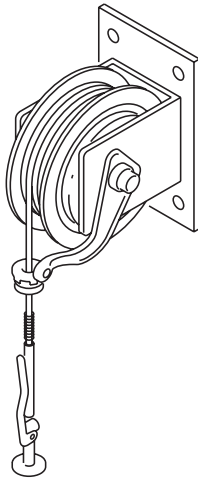

Reel Kleen Hose Reels	
General	
Reach of hose RK15	4.5m (15ft)
Dimensions (h x w x d)	560mm x 92mm x 313mm
Reach of hose RK35	10m (35ft)
Dimensions (h x w x d)	640mm x 194mm x 384mm
Installation information	
Water pressure range	2.1 to 13.8 bar (30 to 200 PSI)
Water temperature	82°C (180°F) maximum
Water connection	3/8" IPS Female
Water feed	15mm copper pipe
Features	
	Reinforced rubber hose
	Re-coil system
	Built-in multi-bracket for wall or ceiling mounting
Product code details	
U05/013	Reel Kleen 15 (RK15)
U05/012	Reel Kleen 35 (RK35)
Shipping specification	
Reel Kleen 15 (RK15)	
Packing dimensions (h x w x d)	390mm x 330mm x 18mm
Packing volume	0.023m ³
Packing weight (gross/net)	9kg/8kg
Reel Kleen 35 (RK35)	
Packing dimensions (h x w x d)	510mm x 290mm x 380mm
Packing volume	0.056m ³
Packing weight (gross/net)	17kg/14kg

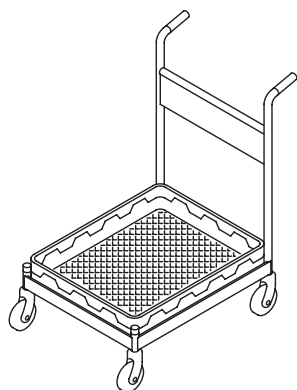
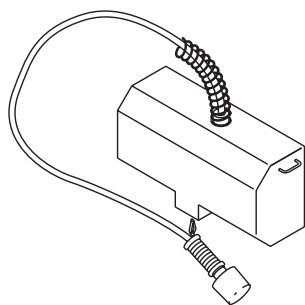

Pot Boy	
General	
Reach of hose	1.5m
Dimensions (h x d)	245mm x 625mm x 265mm (not including pipework)
Safety	Hydraulic brush head system provides electrical isolation and overload protection.
Electrical Information	
Motor	0.37kW (0.5HP)
Voltage	220/240-1-50
Fuse rating	1 phase (13A)
Installation information	
Head speed	360rpm
Hydraulic fluid pressure	30 bar
Mounting height	1.15m above sink
Power Supply	Requires suitable fused power supply within 2m of machine. Supplied with 2.5m cable.
Features	
	Wall mounting plate
	Foot operated pneumatic switch
	Long lasting nylon brush head
	Magikut exterior scrubber
Customer options	
Options	Mobile trolley with 500mm x 500mm dishwasher tray
Product code details	
F64/100	Pot Boy
S64/090	Mobile trolley with 500mm x 500mm dishwasher tray
U07/012	Long lasting nylon brush head
U07/PGW2	Magikut exterior scourer (5 pads)
Shipping specification	
Pot Boy	
Packing dimensions (h x w x d)	660mm x 290mm x 710mm
Packing volume	0.14m ³
Packing weight (gross/net)	32kg/28kg
Trolley	
Packing dimensions (h x w x d)	630mm x 420mm x 770mm
Packing volume	0.20m ³
Packing weight (gross/net)	10kg/9kg

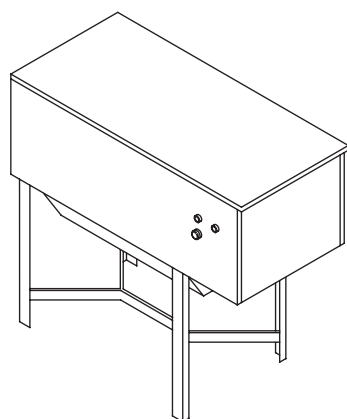

A4 Burnisher	
General	
Capacity	Up to 350 pieces of cutlery Silver items up to 260mm diameter
Dimensions (h x w x d)	910mm x 1220mm x 710mm
Lid open height	1500mm
Electrical information	
Motor	0.25kW (0.33HP)
Voltage **	220/240-1-50/60 380/415-3-50
Fuse rating	1 phase (10A) or 3 phase (5A)
Features	
	70kg steel balls
	10kg burnishing powder
	1kg degreasant
	Teapot rod
	Division plates
Product code details	
F62/300	1 phase A4 burnisher
F62/320	3 phase A4 burnisher
S62/096	10kg burnishing powder
S62/095	1kg degreasant
S62/092	5kg steel balls
S62/094	25kg steel balls
Shipping specification	
Packing dimensions (h x w x d)	1280mm x 770mm x 1050mm
Packing volume	1.035m ³
Packing weight (gross/net)	263kg/226kg

** other voltages available on request

Spray Units

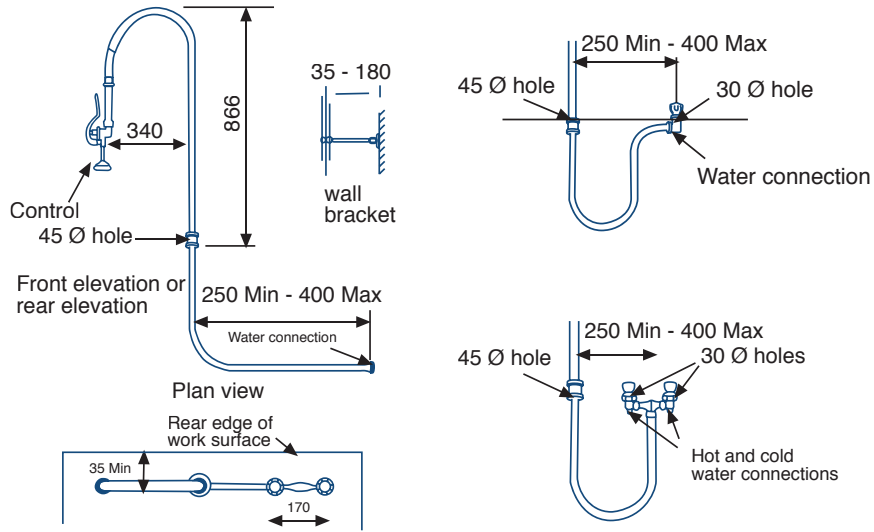

Reel Kleen

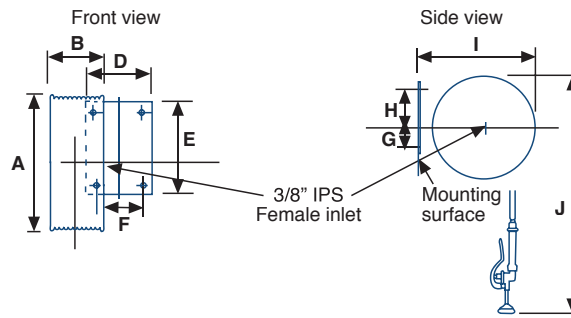

Model	A	B	D	E	F	G	H	I	J
RK15	290	65	92	172	62	71	71	313	560
RK35	336	80	177	253	127	70	133	384	640

Pot Boy

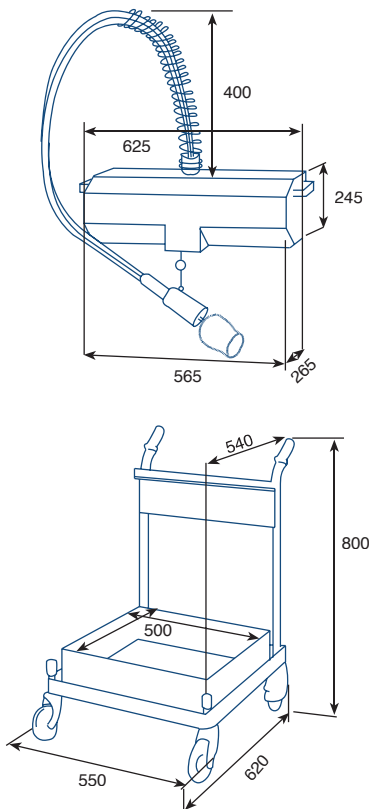

A4 Burnisher

