

ICE MAKER User's Manual

ICM-200A / ICM-200AH
ICM-220ADS / ICM-220AHS
ICM-300A / ICM-300AH
ICM-500AD / ICM-500AH

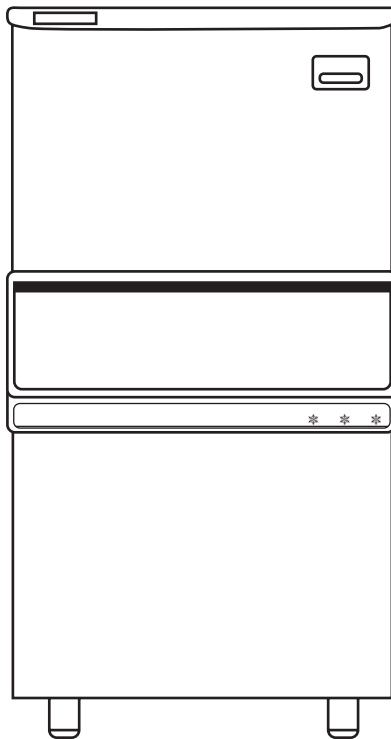

- This machine cannot be used in any other country where the electric voltage for its power supply is not available.
- This product is designed for indoor installation. Please be sure to install it indoors.
- The external appearance, design, color, and/or components of this machine may be changed without prior notice.





INDEX

1. Preparations for safety	3~7
2. Installation	8~17
Installing height controlling footing of container	8
Installing the product and container	8~10
Installing product on shelf	11~12
Specifications for connecting water supply	13
Suitable installation condition and place	14~15
After installation	16
About grounding	17
3. What to check before using the product	18~19
4. Names of main parts	20~22
5. General information about the product	23~24
6. Cleaning (at least once a month).....	25
Cleaning.....	26~27
7. Before requesting for customer service	28





1. Preparations for safety

 Warning	Failure to follow these instructions may result in severe personal injury or death.
 Caution	Failure to follow these instructions may result in parts replacement expense and / or service repair expense.



SHOULD BE DONE



PROHIBITION



DO NOT
DISASSEMBLE



DO NOT
TOUCH



DISCONNECT
POWER PLUG



GROUNDED



Warning

Use a single receptacle for the ice machine.

- ◆ An electrical fire may be caused by a receptacle holding more than one item.
- ◆ Do not use an adapter or an extension cord.

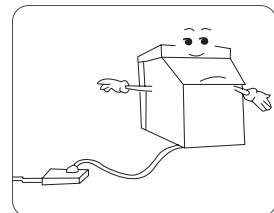

Clean the plug

Clean the plug if covered in foreign material or dust etc. with a clean, dry towel.

- ◆ A fire may occur if plug is not clean.





Warning

Do not place or store heavy items on the top of the product.

- ◆ Damage by excessive weight can cause the unit to overheat and/or fire.

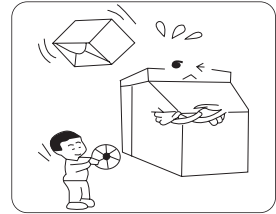

Do not install the machine under humidity area or near the water sprayed zone.

- ◆ Lack of insulation cause a electric leakage, shock and fire.

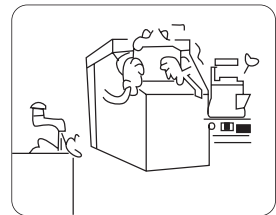

Stop the operation

When the smell of something burning or smoke is emitted from the machine, or if the product malfunctions, immediately unplug the product and stop operation.

- ◆ Operating the product under bad conditions may cause fire or electric shock.

Stop the operation

Do not use flammable gas near the icemaker.

- ◆ It may cause explosion and fire.

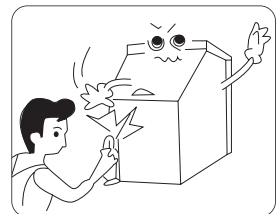

Stop the operation

Replace or tighten the receptacle if it is loose.

- ◆ An electric short or fire can occur.





Warning

Do not disassemble

Do not modify the parts of icemaker, and repair without an authorized person

- ◆ It may happen the fire and extra, ordinary operation, and would result in the serious problem.

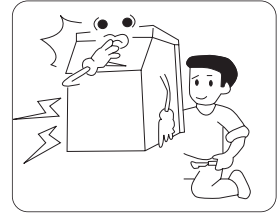

Prohibition

Do not bend the power cord severely, or allow it to be pressed by a heavy matter, which can cause damage to the cord.

- ◆ There is a danger of a current leak, electric shock and/or fire
- ◆ Be sure to contact the customer service center if the power cord or plug gets peeled.

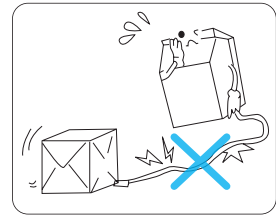

Prohibition

Do not let children hang on the door of the icemaker.

- ◆ Injury to the child or damage to the icemaker may occur.
- ◆ Avoid hanging onto the front door of the ICM-500AD / ICM-500AH .

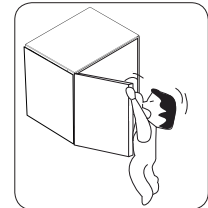
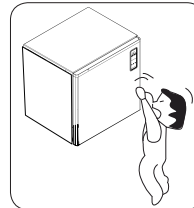

Do not touch

Do not touch or disconnect the power cord with wet hands.

- ◆ May cause an electric shock.

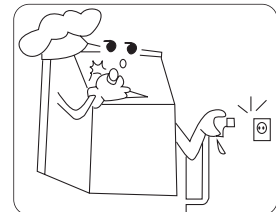

Do not touch

Do not clean the in side of ice maker by sharp tools.

- ◆ It may cause the damage of colling system or electrocution.

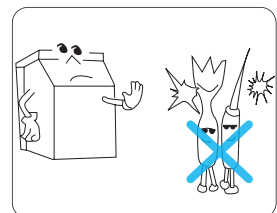



Warning

Disconnect power plug

For long term usage interruption or product shut-down, close the water supply valve, remove the ice from the product and unplug the power cord.

Disconnect power plug

For cleaning or servicing, unplug the power cord, shut off the water feed and wait for the product to come to a complete stop.

- ◆ It may cause electric shock, fire, or injury.

Disconnect power plug

Separate the power plug from the receptacle with holding the plug body.

- ◆ Pulling the power cord or using a screwdriver to unplug may cause fire or electric sparks.

Grounded

The Ice Machine must be connected to a grounded power source.

- ◆ An ungrounded circuit may cause product failure or an electric shock.

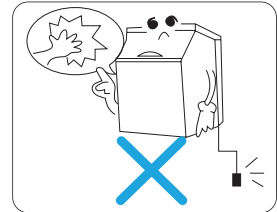

Installing the product

When installing the product on the container, use an appropriate lifting system or 2~3 men to lift the product.

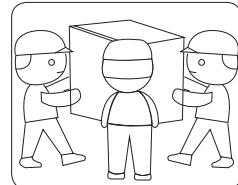

About the power strip

Make sure the power strip supports power higher than rating volts and 16 A.

- ◆ Using multiple appliances on one power strip may cause fire. Thus, be sure to plug only one appliance especially when using this product.

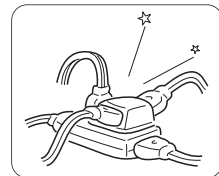



Caution

Caution

Remove any moisture or oil or anything that may cause slipping on the ground near the product.

- ◆ Slipping and hitting the ice maker or sticking one's hand into the bottom will cause injury.

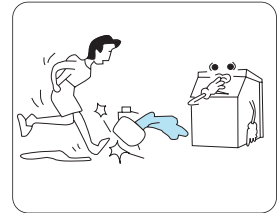

Hand over

As you turn over the icemaker to the other user, please turn over the operation manual, too.

- ◆ Be sure to refer to the user manual for the safest usage by users who are not familiar with the product.

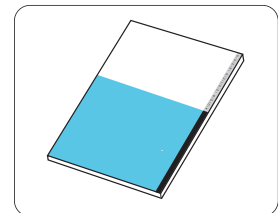

Do not slide the hand or foot in under the icemaker.

- ◆ The bottom of this product has diverse parts including metal sheet, which may cause injury.

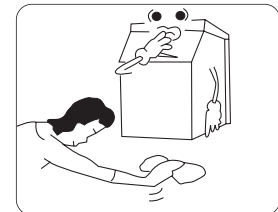

When reconnecting the power cord after disconnection, wait at least 5 minutes before reconnecting.

- ◆ Plugging in right away may cause overload and malfunction.

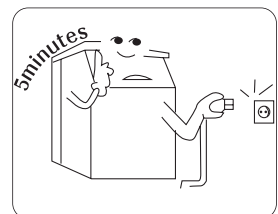

This product senses ice with voltage (resistance); since ice made of distilled water may not be recognized, tap water is highly recommended.





2. Installation

Installing height controlling footing of container

Put the product on the container and make sure it is gripped tightly as shown below. The manufacturer is not liable for any incident or injury resulting from the fall of the product during use.

〈 Installing the container 〉

1. Assemble the 4 ice-controlling footings on the bottom of the container.

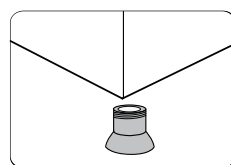

2. Adjust the height of the footings by turning them so that they are all of the same height and the product can be put evenly.

◆ The footings should be inserted deeper than 10 cm(4").

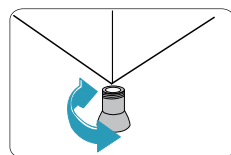

Installing the product and container (for the ICM-200A / ICM-200AH, ICM-220ADS / ICM-220AHS, ICM-300A / 300AH)

1. Use the lifting device to put the product on top of the container.
If no lifting device is available, 2 or 3 men should lift the product.

◆ The right side of the product has the compressor and weighs more, so more force has to be applied.

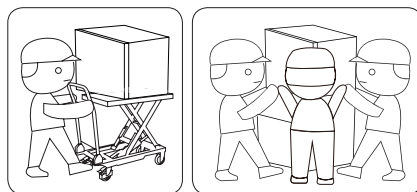

2. The product weighs 75 ~ 100 kg(165~220 lbs), so it is not easy to put on the container in one attempt. Put the product on the loading part as the first step. (The loading part should be higher than 1 m(40"))

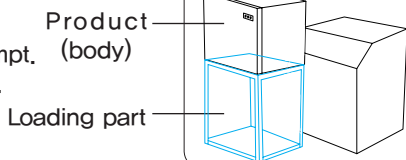

3. Move the product from the loading part to the above of container as the second step.

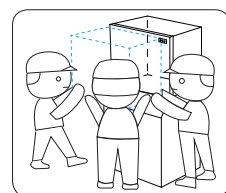



2. Installation

4. Move the product slowly on the container so that the back and sides match.

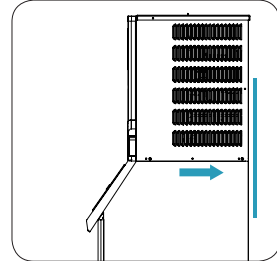

5. Detach both side panels by loosening the bolts.

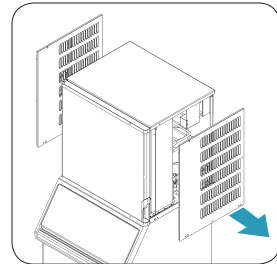

6. Assemble the container and product with the included bolts.
◆ excluded ICM-220ADS / ICM-220AHS.

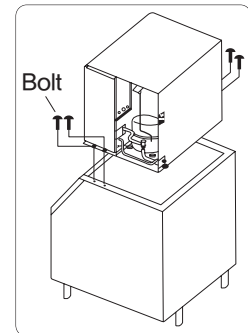

7. Reassemble the side panels to complete installation of the product.

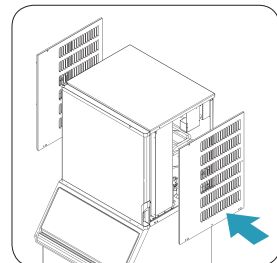

8. Use the brackets to anchor the product to the wall.

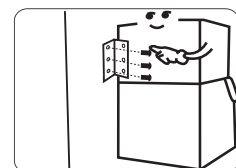



2. Installation

Installing the product and container (for the ICM-500AD / ICM-500AH)

1. Using a lifting system or more than 3 people to lift the product on the container is recommended.

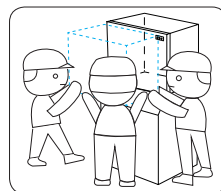

2. The product weighs about 110 kg(243 lbs), so it is not easy to put on the container in one attempt.
Put the product on the loading part as the first step.
(The loading part should be higher than 1.2 m(47"))

- ◆ The right side of the product has the compressor and weighs more, so more force has to be applied by at least 2 people.

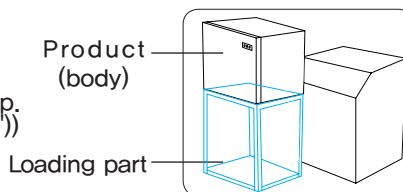

3. Move the product from the loading part to the above of container as the second step.
Make sure the product is oriented toward the vertical line at the back of the container.

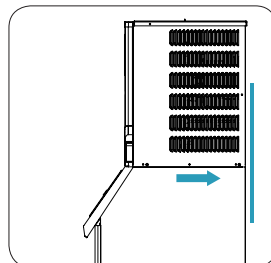

4. Detach the handles after installing the product above the container, and then reassemble both side panels with bolts.

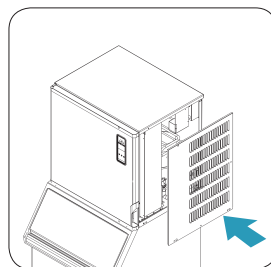

5. Use the brackets to anchor the product to the wall.

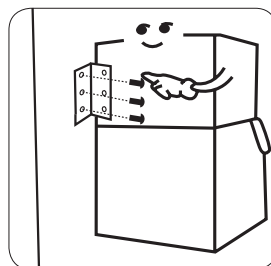



2. Installation

Installing product on shelf



Thank you for purchasing the product. Be sure to familiarize yourself with the instructions below for correct installation and apply caution to prevent any incident.

1. Open the top cover and loosen the tightening bolt on the top plate.
(Detach the front cover using the same method.)

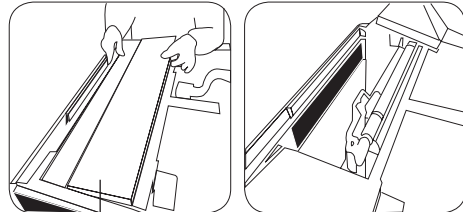

Upper plate

2. After detaching the front cover, loosen the bolts from the protection cover on the upper right part.

Protection cover

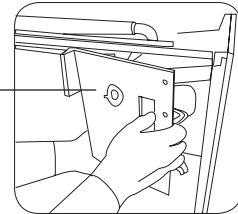

3. Fix the included side brackets as in the figure.
(Make sure the screws at the front are slightly tightened.)

Side bracket

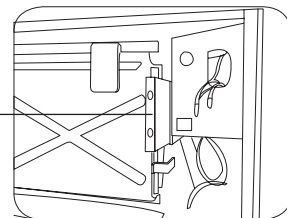

4. Insert the bracket downward and fit the bracket grooves to the side bracket's screws as in the figure on the right.
(Tighten the two screws for the left side of the bracket and ice maker.)

Bracket

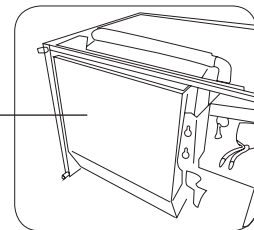

5. Upon completing processes up to No. 4, please place the second ice maker on the lower part ice maker.
The enclosed foam needs to be attached on the upper surface of the ice maker placed at the lower part before placing the upper part ice maker.

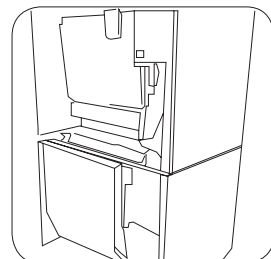



2. Installation

6. Upon completing processes up to no. 5, attach the included slide bracket. (Attach the folded upper part of the slide bracket by hanging it on the container. Tighten the screws between the lower bracket and upper slide bracket.)

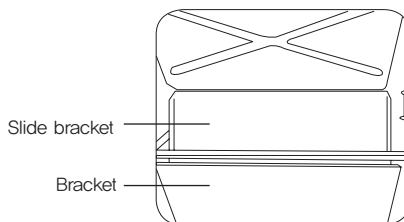

7. Install the protective cover so that moisture from the container of the ice maker above will not be accumulated in the control box, both in the upper and lower parts, as in the figure.

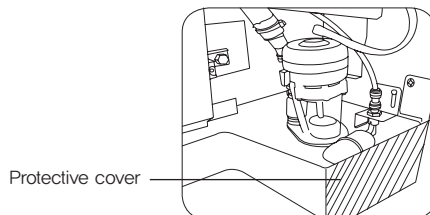

8. Refer to the figure on the right, which shows the completed installation.

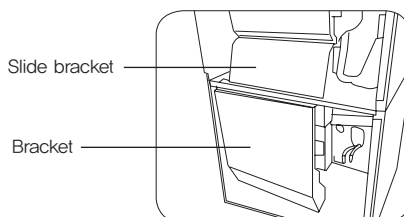

9. Attach the front panel and assemble the upper cover. Attach the included fixing bar on both sides so that the installed product will not be affected by external shock. Installation has been completed.

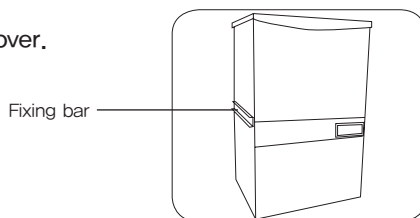



2. Installation

Specifications for connecting water supply

[Connecting water piping / hose]

	Appropriate water temperature	Water pressure	Appropriate piping /hose size
Ice making water supply	10 ~ 32 °C(50~90 °F)	138 ~ 550 kPa(20~80Psi)	3/8" PT
Ice making water drain	—	—	3/4" PT

Too high temperature of the ice-making water will decrease the amount of ice to be made; too low pressure will prevent ice from being made at all. Install an auxiliary pressure pump in this case.

[ICM-200A / ICM-200AH, ICM-300A / ICM-300AH]

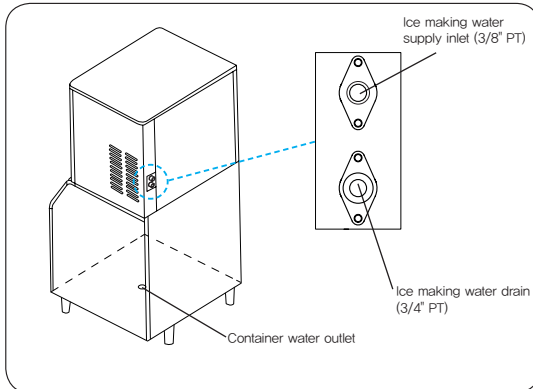

[ICM-500AD / ICM-500AH]

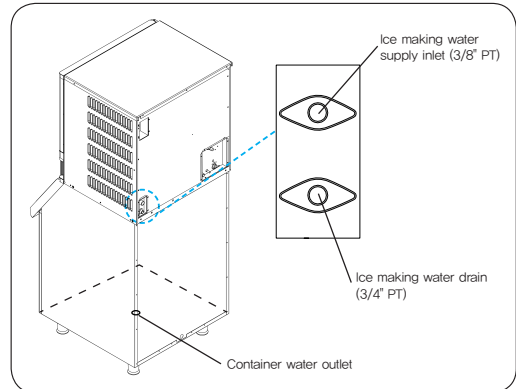

[ICM-220ADS / ICM-220AHS]

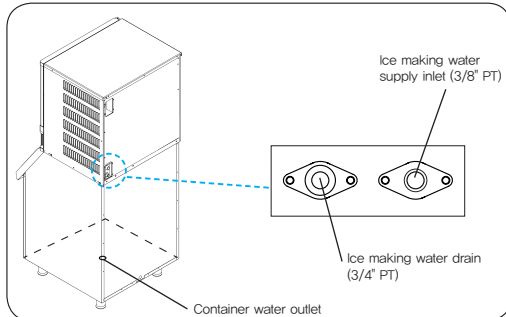

(230 V, 50 Hz)





Suitable installation condition and place

● Places without heat source

- ◆ The product has to be installed at places without a heat source such as stove or gas range or any place with ambient temperature of $10 \sim 38 \text{ }^{\circ}\text{C}$ ($50 \sim 100 \text{ }^{\circ}\text{F}$).

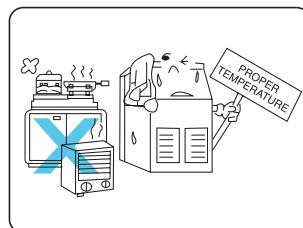

● To the place with enough spaces from the walls

- ◆ The minimum distance required is 20 cm (8") from the walls for normal operation.

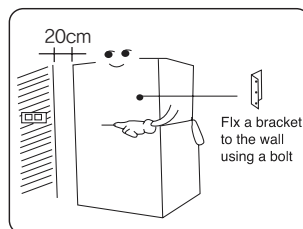

● To the place with good ventilation

- ◆ Poor ventilation will lead to poor ice-making capability.

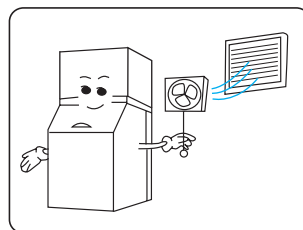

● On even surfaces

- ◆ Uneven surface will result in too much vibration or noise. (The surface angle must be less than 1°)
- ◆ Installing the product on an uneven surface may cause it to fall or slip and cause injury. Make sure that the product is installed on an even surface.

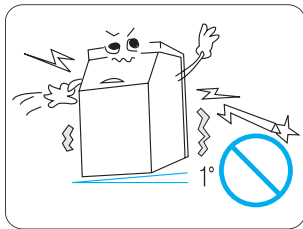



- Be sure to install the product in clean places.
 - ◆ Ice will be used for food or human consumption. Thus, the installation site must be clean and hygienic.

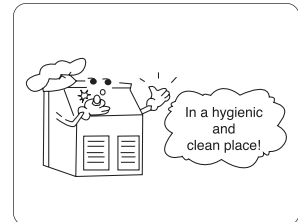

- The product must be installed indoors.
 - ◆ The outlet of the drain hose has to face downward to enable smooth draining.
 - ◆ The product must not be installed outside.

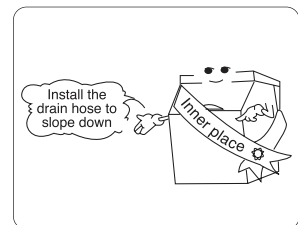

- In a place inaccessible to children.
 - ◆ Be sure to apply caution so that children neither get injured nor play with ice.

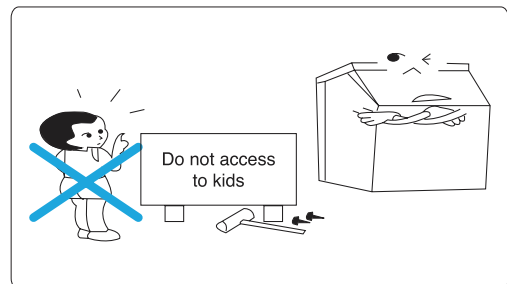

◆ Make sure to observe the following.

- Since the product makes use of water, proper water supply and draining facility are required.
- Water may leak during installation or operation for diverse reasons. Thus, proper draining must be prepared. Since there is danger of electric shock due to moisture from leak, be sure to observe the following:



Warning

1. When installing the product indoors, be sure to have a natural drainage facility and make the floor waterproof, especially if the floor may get damaged due to leak.
 2. A draining outlet must be available at the installation site; be sure to connect the drain hose.
 3. Make sure that the floor is sloped so that any leaked water gets drained away even if the drain hose gets dislodged or damaged. Install a water overflow prevention wall to prevent damage.
- ※ Adjust the height by turning the footing if the floor is sloped to set it stably.
 - ※ The manufacturer will not be liable for any problem arising from failure to comply with the warnings above, dislodged / damaged water supply hose, or inappropriate drain facility.





After installation

- **Protection of the water supply hose**
Do not put any heavy object on the water supply hose. Do not step on it either.

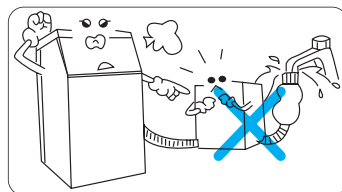

- **The appropriate water pressure, water temperature, or ambient temperature is...**
This ice maker must be used under conditions of 1~5 kg/cm², water supply of 10~32 °C(50~90 °F), and ambient temperature of 10~38 °C(50~100 °F).



Connect potable water supply only.

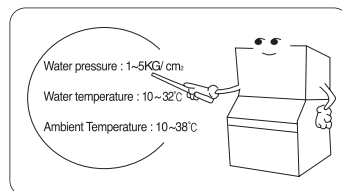

1. Plugging into the Power Supply.

- ◆ This icemaker operates only on rating volts.
Plug it into a rating outlet only.

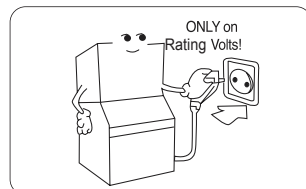

2. Supplying Water to the Icemaker.

- ◆ Open the faucet to supply water to the icemaker.

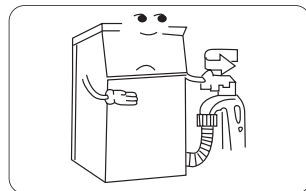

3. Ice making

- ◆ Turn on the power switch inside the product to start ice making (ICM – 500AD / ICM-500AH).
- ◆ Turn on the power switch outside the product to start ice making (ICM-200A / ICM-200AH, ICM-220ADS / ICM-220AHS, ICM-300A / ICM-300AH).

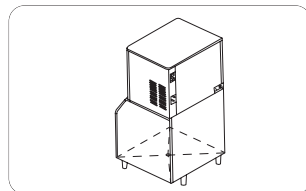

4. Ice Making Operation.

- ◆ Although the length of operation time varies depending on the ambient temperature and or the water temperature, one (1) cycle of ice-making operation is completed 20~30 minutes after the operation starts.

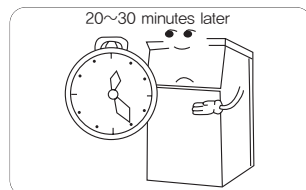



About grounding

※ Be sure to ground the product to prevent electric shock.

⦿ **Grounding method – if there is a grounding terminal**

In case of plugging the icemaker into an rating AC outlet equipped with a grounding terminal, extra grounding is not necessary.

⦿ **Grounding method – if there is no grounding terminal**

In case of plugging the icemaker into an rating AC outlet without a grounding terminal, connect the ground wire to the copper plate and then bury it under the ground.

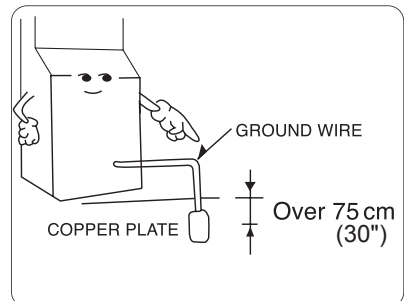

Do not ground the product on the following:

Gas piping, water supply, lightning rod, telephone line, or any connection part

※ Plastic water piping or non-insulated material will not provide a grounding effect.

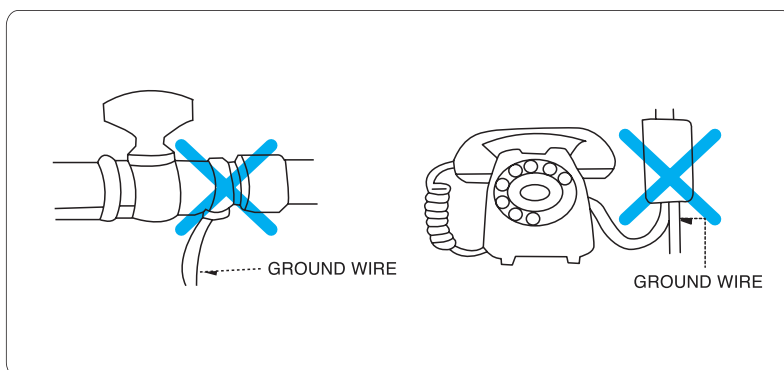



3. What to check before using the product

3-1. Removal of Tapes before Operation

After removing the front cover, be sure to get rid of the shake prevention tapes stuck to the sensor and the water curtain.

- Unless the tapes are removed, the machine will not work.

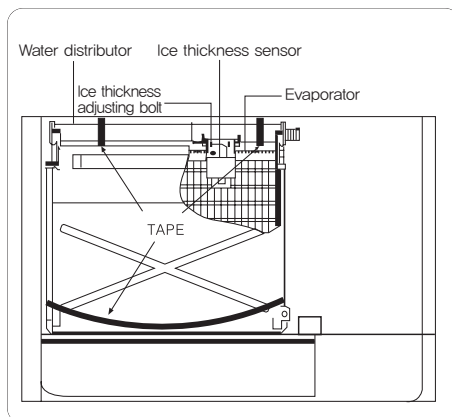

3-2. Where Water Pressure Is Very Low

If the machine has been installed in a place where water pressure is very weak, remove the front cover and then adjust the FLOATER height to be higher within the range of avoidance of overflow by slightly unscrewing the water level adjusting screw.

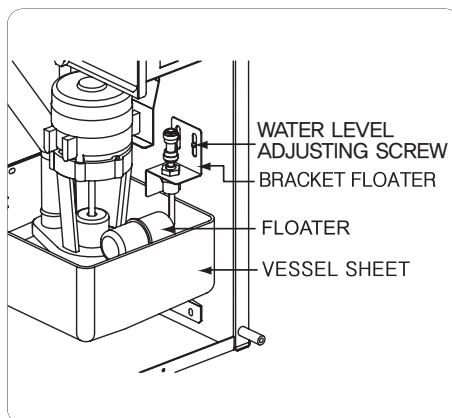

3-3. How To Adjust Ice Thickness

You can increase the thickness of the ice by turning the ice thickness adjusting bolt clockwise until it is about 6~8 mm(0.24~0.31") away.

(Usually, it is recommended that you avoid adjusting ice thickness like this in order to prevent the machine from getting excessively cold.)

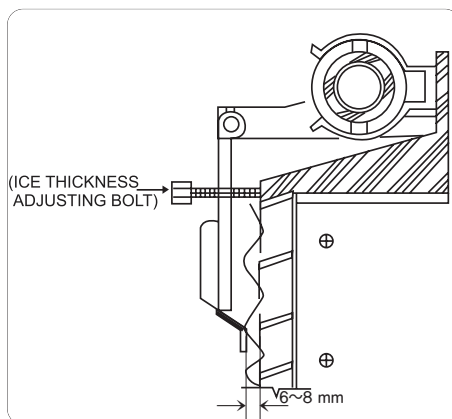



When turning off the drain valve

1. Open the front panel
(by loosening two screws)
2. Turn off the drain switch of the control box;
water draining of a certain amount (1,300 cc)
per cycle will be stopped.

※ Applicable if the user wants to increase
the amount of ice.
(Ice quality may deteriorate slightly.)

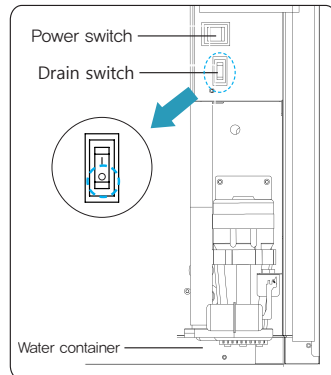

[ICM-500AD / ICM-500AH]

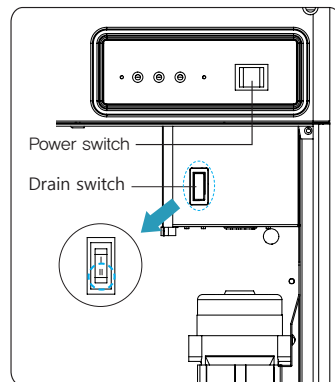

[ICM-200A / ICM-200AH,
ICM-300A / ICM-300AH]

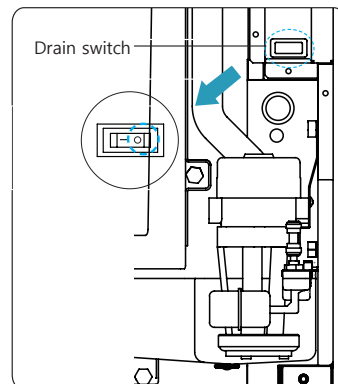

[ICM-220ADS / ICM-220AHS]





4. Names of main parts

(ICM-200A / ICM-200AH, ICM-300A / ICM-300AH)

[FRONT VIEW]

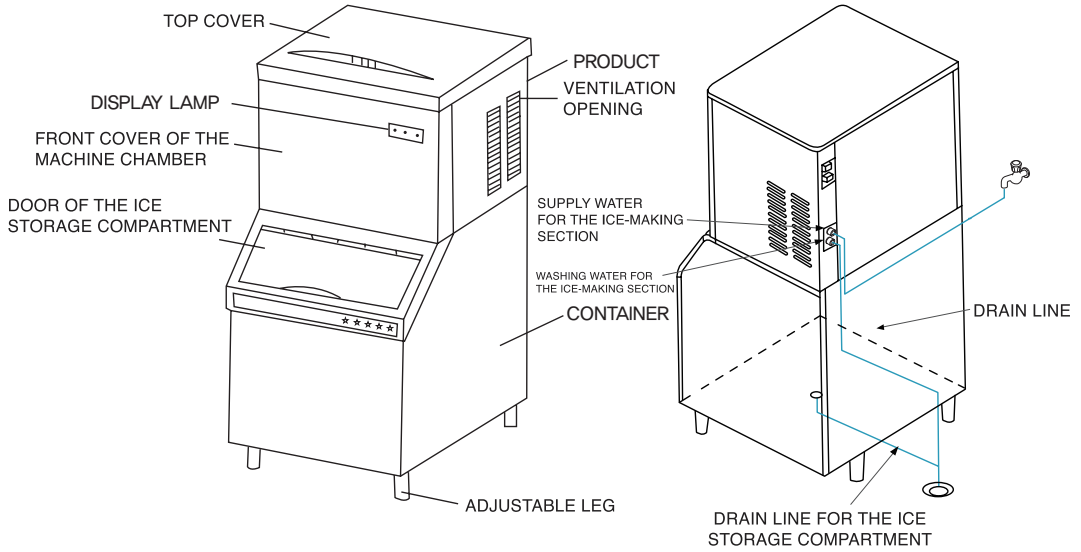

[Diagram of the front inside]

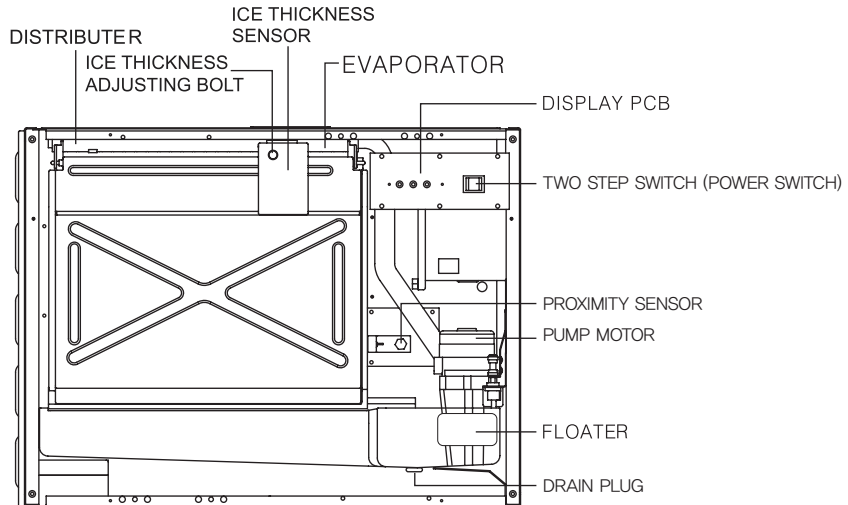



4. Names of main parts (ICM-220ADS / ICM-220AHS)

[FRONT VIEW]

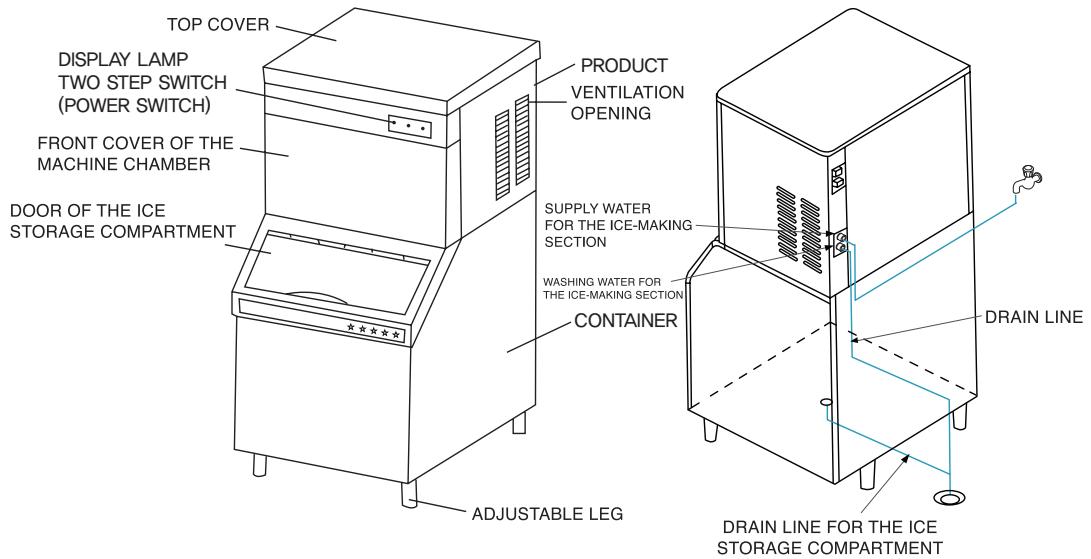

[Diagram of the front inside]

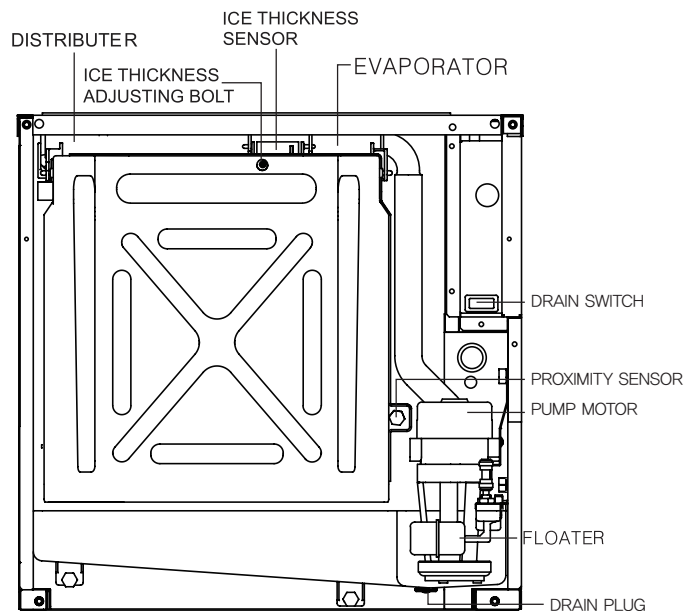



4. Names of main parts (ICM-500AD / ICM-500AH)

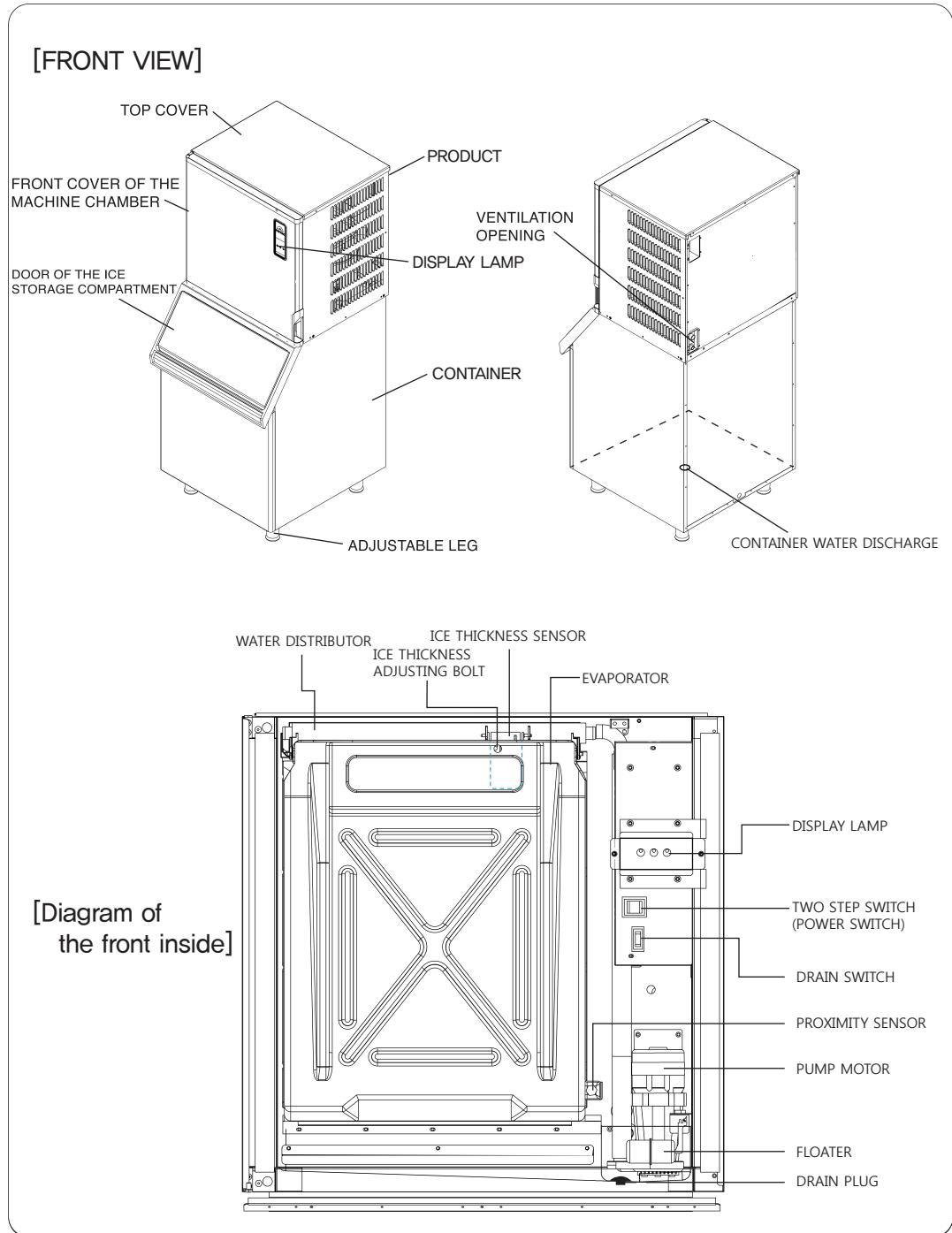



5. General information about the product

– (230 V, 50 Hz)

ITEM	UNIT	SPECIFICATIONS							
		ICM-200A	ICM-300A	ICM-500AD	ICM-500AH	ICM-220ADS	ICM-200AH	ICM-300AH	ICM-220AHS
Ice Size/Capacity	mm	29 X 29 X 22		22 X 22 X 22	9,5 X 29 X 22	22 X 22 X 22	9,5 X 29 X 22		
	EA	140		418	612	210	360		280
	inch	1,14 X 1,14 X 0,86		0,86 X 0,86 X 0,86	0,37 X 1,14 X 0,86	0,86 X 0,86 X 0,86	0,37 X 1,14 X 0,86		
Power Supply	–	230 V, 50 Hz							
Weight	Before being packaged	kg	75	95	110	70	74	95	70
		lb	165,3	209,4	242,5	154,3	163,1	209,4	154,3
	After being packaged	kg	77	97	123	82	76	97	82
		lb	169,7	213,8	271	180,7	167,5	213,8	180,7
Cooling Unit	Output	HP	1,2	1,5	2,0	1,0	1,2	1,5	1,0
	Current	A	6	5,5	10,7	3,5	6,0	5,5	3,5
	Cooling Motor	–	Fan Motor						
Ice Thickness Adjustment Control	–	Control by ICE probe sensing							
Full Ice Amount Sensing Control	–	Control by the proximity switch							
High Pressure Sensing Control	–	Automatic reset type.							
Time Control	–	MICOM CONTROL							
Rate Power Consumption (when the ice)	W	1250	1300	1710	600	1250	1300	600	
Conditions for Use	°C	Supply water temperature : 10~32 °C(50~90 °F) Water pressure : ice making section : 138~550 kPa, cooling section : 138~550 kPa							

※ The maximum ice capacity is based on 10°C ambient / water temperature, but may vary depending on the installation condition; high temperature in summer may severely affect the capacity.





6. Cleaning (at least once a month)

1. Turn off the top right power switch. (ICM-200A / ICM-200AH, ICM-220ADS / ICM-220AHS, ICM-300A, ICM-300AH)
1. Turn off the power switch inside the front cover. (ICM-500AD / ICM-500AH)
2. Detach the drain plug to remove any residue in the vessel.
3. Detach the water curtain and clean the square panel with soft cloth when cleaning the evaporator.
4. Detach the water distributor and clean it thoroughly.
5. Dilute mild detergent (for home use) to clean the product (1 spoonful per liter of water). After cleaning the product with detergent, be sure to rinse the product for more than 20 minutes; there should be no bubbles left from detergent.
※Do not use detergent for laundry.

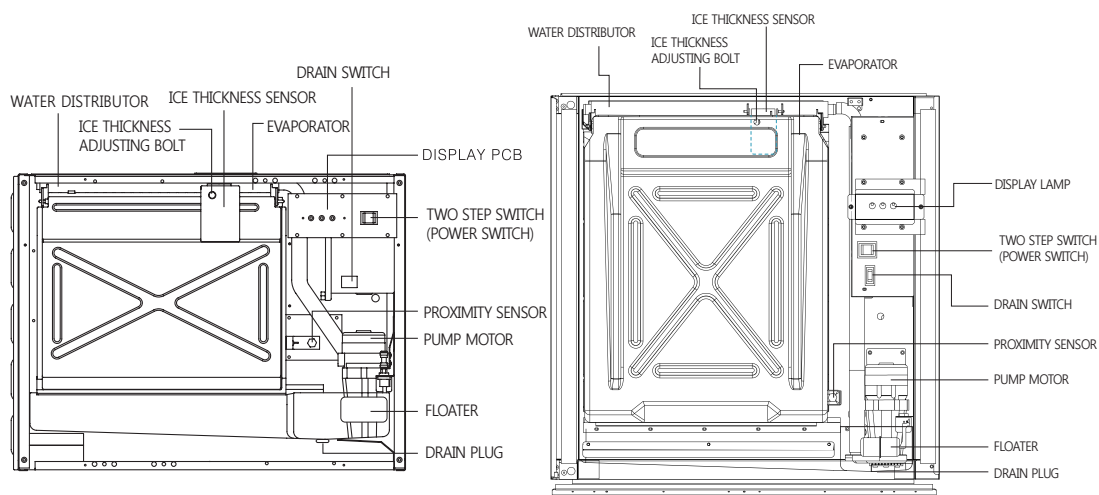

[ICM-200A / ICM-200AH, ICM-220ADS / ICM-220AHS, ICM-300A / ICM-300AH]

[ICM-500AD / ICM-500AH]

※ Cleaning the condenser (per week): Air-cooled model

Use a (portable) vacuum cleaner to remove any dust from the condenser panel surface.





6. Cleaning

CLEANING PROCEDURE

Refer to cleaning procedure for complete details, at least two months clean the machine.

1. Set the main switch to the OFF position after ice falls from the evaporator at the end of a harvest cycle.
Or, set the switch to the OFF position and allow the ice to melt off the evaporator.
CAUTION—Never use anything to force ice from the evaporator. Damage may result.
2. Remove all ice from the bin and water from the internal basin.
3. Remove the upper or front panel and close the water supply tap.
4. Pour the proper amount of cleaner (mix cleaner with water) to the evaporator and internal basin.
NOTE—If the ice-cube maker requires cleaning, clean it with a solution of three spoon of cleaner with 0,624 gallons(1 liter) of water.
5. To start a cleaning cycle, move the toggle switch to the WASH position and main switch to the ON position for small type models.
Move the main switch to the WASH position for large type models.
6. It will be worked on twenty minute cleaning cycle.
7. After twenty minute, move the main switch to the OFF position.
8. Clean the evaporator, cover and bin using brush with cleaner(2 liter).
9. When the cleaning process stops, and empty the water out of internal basin.
10. When the remove all water from the internal basin, open the water supply tap. Move the toggle switch to the WASH position and main switch to the ON position for small type models.
11. It will be worked on ten minute washing cycle.
12. After ten minute, move the main switch to the OFF position.
13. When the remove all water from the internal basin, move the toggle switch to the WASH position and main switch to the ON position for small type models.
14. Assemble a upper or front panel into the ice-cube maker.
15. When the finished filling operation, start the ice making system.

SANITIZING PROCEDURE

Refer to this detailed sanitizing procedure and clean the machine at least once a month.

1. Set the main switch to the OFF position after ice falls from the evaporator at the end of a harvest cycle.
Or, set the main switch to the OFF position after ice is melted on the evaporator.
※ CAUTION : Never remove ice from the evaporator forcibly. Damage may result.
2. Remove all water and ice from the bin and the internal basin.
3. Open the front panel (by loosening two screws) and close the water supply tap.
4. Pour 18L (4.76 gallon) of water to the basket and add 4L (1.06 gallon) of sanitizer and mix.
※ Note : If the bin requires sanitizing, use 10L of the mixed sanitizer (18L water & 4L sanitizer).
5. To start a sanitizing cycle, move the main switch to the WASH position after filling the internal basin with the mixed sanitizer.
6. Please do the sanitizing for 20minutes.
7. After twenty minutes, move the main switch to the OFF position.
8. Use brushes when cleaning the evaporator, evaporator frames, the bin and the inside areas that contact water.
(Use 2L of the mixed sanitizer.)
9. Take out the water curtain from the machine and clean with a brush. (Refer to the upper drawing.)
(When disassembling the water curtain, take away the hinges on the right and the left of the top.)
10. When the sanitizing is done, empty the bin and the internal basin.
11. After emptying the bin and the water basin, open the water supply tap and move the main switch to the WASH position and start sanitizing again. (First round sanitizing)
12. Please do the sanitizing for 20minutes.
13. After twenty minutes, move the main switch to the OFF position.
14. When the sanitizing is done, empty the bin and the internal basin and move the main switch to the WASH position and start sanitizing again. (Second round sanitizing)
15. Please do the sanitizing for 20minutes.
16. After twenty minutes, move the main switch to the OFF position.
17. Empty the bin and the internal basin and pour water into the internal basin.
18. The sanitizing is done. Move the main switch to the ICE and start using the machine.
19. Finally, tighten the screws at the top and the bottom areas of the front panel.



Sanitizer





[WASH function]

1. Turn off the top right power switch.
(ICM-200A / ICM-200AH, ICM-220ADS
/ ICM-220AHS, ICM-300A / ICM-300AH)
1. Turn off the power switch inside the front cover.
(ICM-500AD / ICM-500AH)
2. Remove all ice; discard them or store in a proper
container such as ice box or freezer.
3. Dilute 30 g of mild detergent in 8 ℓ of water
at 35~45 °C and pour into the water supply container.
4. Turn on the power switch at the back to WASH.
The pump motor will run for about a minute
and a half, and then stop for around 30 seconds.
This cycle will be repeated 5 times.
5. Repeat the cycle above for 2 or 3 times.
Refill the container with mild detergent as needed.
6. Dilute detergent with water to clean the ice container,
hoses, ice bucket, or water container.
7. Put back the ice in the container after cleaning.

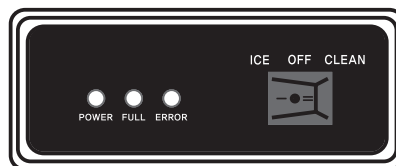

[ICM-200A / ICM-200AH, ICM-220ADS
/ ICM-220AHS, ICM-300A, ICM-300AH]

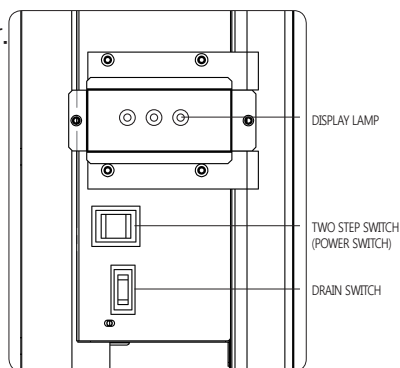

[ICM-500AD / ICM-500AH]



Caution

- Be sure to clean the ice bucket periodically as with other food container.
- The handle of the ice bucket may get exposed to viruses from the user's hands, etc.



Warning

- Detergent may burn your hand.
- Do not force the person to vomit who drank or inhaled the detergent accidentally.
- Provide ample amount of milk or water to the person and contact a doctor immediately.
- In case the detergent came into contact with skin, wash with water.
- Be sure to keep the detergent in a place where children may not tamper with it.





7. Before requesting for customer service

Check the following if operation of the product is not satisfactory:

If you find the operation unsatisfactory after checking, contact the local dealer or customer service center.

Provide the following details:

(Model, serial number, name of local dealer, date of purchase, and current condition of the product)

Operating Condition	Check Points	Measures
1. Machine does not work.	1. Is the machine supplied with electric power? (Did you plug it to the electrical outlet?)	1. Supply it with electric power. (Plug it to the electrical outlet.)
	2. Did the high pressure safety switch (red button) at the upper back work?	2. Check the cooling water. In the case of the air-cooled type, remove dust from the condenser.
	3. Is the power supply of the machine using rating volts $\pm 10\%$?	3. Check the power supply. Use the only rating volts outlet.
	4. Is the three-level switch (inside the front cover) in the ICE MAKING position?	4. If it's in the OFF position or in the WASHING position, change it to ICE MAKING position.
	5. WATER CURTAIN is open?	5. Check the water curtain
2. Too late ice formation	1. The machine is too dirty.	1. Clean it using the cleaning method described in Paragraph 6.
	2. The ambient temperature is too low. (air-cooled type)	2. Adjust the ambient temperature to be above 10 °C(50 °F)
	3. Dregs gathered in the cooling water flow regulating valve. (water-cooled type)	3. Clean the valve using the cleaning method described in Paragraphs 6.
	4. The ice thickness sensor is too wide.	4. Adjust it to 6~8 mm(0.23~0.31 inches).
3. Too late ice formation	1. Water supply is too weak.	1. Increase the water supply pressure. Clean the filtering device (strainer) at the back.
	2. The machine is too dirty.	2. Clean it using the same method described in Paragraph 6.
4. Poor ice formation or poor water freezing	1. The ice thickness sensor works abnormally.	1. Use the adjusting bolt to keep it 6~8 mm(0.23~0.31 inches)wide.
	2. The water level is too high or too low.	2. Adjust the FLOATER higher or lower.
	3. FLOAT is strange.	3. Check whether it's working normally.
	4. Filtering device (strainer) is stopped up.	4. Take apart the strainer at the back and clean it.
	5. Operating pressure is too high.	5. Refer to 3-2).
5. Too small quantity of ice production	1. Water is too dirty.	1. Clean it using the same method described in Paragraph 6.
	2. Water is in short supply.	2. Check the water supply pressure or whether water supply has been suspended.
	3. The condenser is dirty.	3. In the case of the air-cooled type condenser, clean the aluminum fins at the back.
	4. The ambient temperature is too high.	4. Adjust the ambient temperature to be below 38 °C(100 °F)
6. Water stagnant in the storage container	1. The drain opening is higher than the container.	1. Install the drain opening lower than the container.
	2. The drain opening is stopped up.	2. Clean the hose.

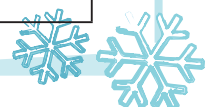



Product Warranty Card

Product Name	Ice Maker	Warranty Period
Model Name	ICM-200A/AH/ADS/AHS ICM-300A/AH, ICM-500AD/AH	1 year after purchasing the product
Serial Number		
Purchased Date	Year ____ Month ____ Day ____	
Warranty Expiration	Year ____ Month ____ Day ____	
Customer Address		Year ____ Month ____ Until
Customer Name		
Phone Number		

1. The free-of-charge service is provided within the warranty period about the failures is sued while normal operations.
2. After checking the user manual, contact the service agency for the failures.
3. Charged service is provided even within the warranty period in the following cases:
 - Failure caused by careless use or improper repair/modification.
 - Failure caused by not following the instructions in this user's manual.
4. Repair after warranty expiration: Charged service is provided.
5. For repair, provide the product warranty card to the service engineer.
6. This product warranty card is applied in the local area.
7. This card is not reissued so please keep it in a safe place.

● Contact Details : **BLUE ICE**
MACHINES

Blue Ice Machines Ltd
Unit G
Leaside Trading Estate
Leaside Rd, Waltham Abbey, EN9 1AE
TEL: 0208801 6919
Website: www.blueicecreammachine.co.uk
Email: info@blueicecreammachine.co.uk



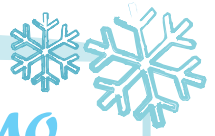

MEMO





MEMO



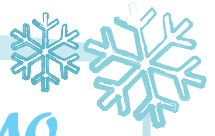

MEMO



