

## COUNTERTOP

## DRY HOLDING & DISPLAY CABINETS

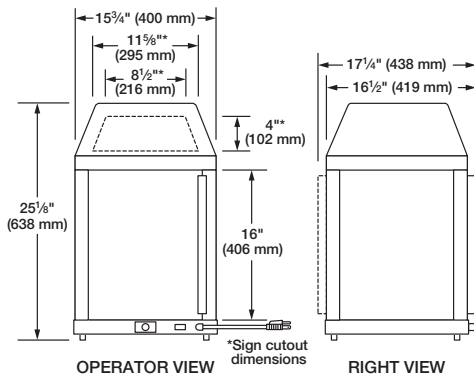

OPERATOR VIEW

RIGHT VIEW

### DIMENSIONS

MDW-1X: 15 3/4"W x 16 1/2"D x 25 5/8"H  
(400 x 419 x 638 mm).

MDW-2X: 15 3/4"W x 17 1/4"D x 25 5/8"H  
(400 x 438 x 638 mm).

Cabinet Opening: 12 1/2"W x 16"H (318 x 406 mm).

Trapezoid Shape Sign Holder: 8 1/2"W at top x 4"H x 11 5/8"W at bottom (216 x 102 x 295 mm).

### SPECIFICATIONS

Model	Type	Rack Style	Shipping Weight
MDW-1X	1 Doors	3-Shelf Adjustable	80 lbs. (36 kg)
MDW-2X	2 Doors	3-Shelf Adjustable	80 lbs. (36 kg)

### VOLTAGE

120 volts, 470 watts, 3.9 amps (NEMA 5-15P).

### CORD LOCATION

Facing controls, lower right corner.

Choose a *Designer Color* to match any décor.



Warm Red    Black (standard)    Gray Granite    White Granite    Navy Blue    Hunter Green

Printed colors are a representation and may not exactly match our *Designer* colors.



Model MDW-1X  
 In *Designer* black with optional hood with backlit sign cutout on one side (graphic included)

## MINI DISPLAY WARMER NON-HUMIDIFIED DISPLAY CABINETS

Warm cookies. Hot sandwiches. Soft pretzels. Make anytime the right time for these types of items. This non-humidified, compact model keeps them hot and ready for your customers to grab-and-go.

- Merchandising flexibility thanks to magnetically adjustable slant or horizontal shelves for maximum visibility
- Single-door or pass-through models available for server and self-serve operations
- Perfect for locations with limited counterspace

# MDW

