

SPECIFICATIONS

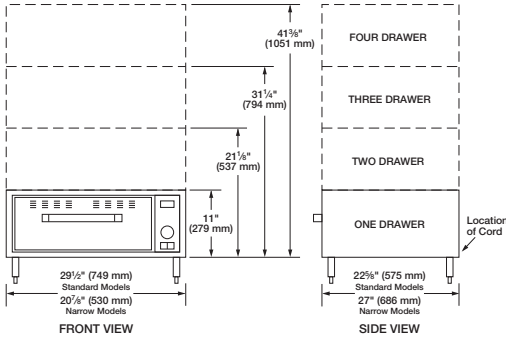

Freestanding Models

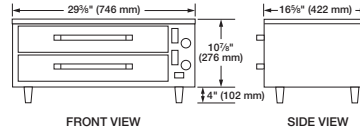

Split Drawer Model

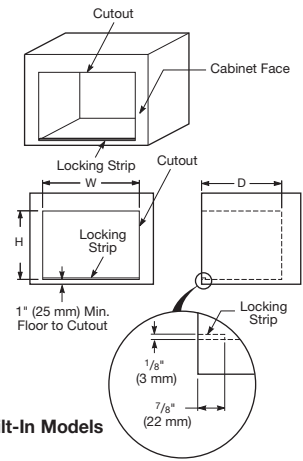

Built-In Models

Freestanding – Standard

Model [▲]	Watts	Amps [★]	No. of Drawers	Shipping Weight
HDW-1	450	3.8	One	97 lbs. (44 kg)
HDW-2	900	7.5	Two	168 lbs. (76 kg)
HDW-3	1350	11.3	Three	232 lbs. (105 kg)
HDW-4	1800	15.0	Four	296 lbs. (134 kg)

Freestanding – Narrow

Model [▲]	Watts	Amps [★]	No. of Drawers	Shipping Weight
HDW-1N	450	3.8	One	97 lbs. (44 kg)
HDW-2N	900	7.5	Two	168 lbs. (76 kg)
HDW-3N	1350	11.3	Three	232 lbs. (105 kg)

Built-In – Standard

Model [▲]	Watts	Amps [★]	No. of Drawers	Shipping Weight
HDW-1B	450	3.8	One	88 lbs. (40 kg)
HDW-2B	900	7.5	Two	159 lbs. (72 kg)
HDW-3B	1350	11.3	Three	223 lbs. (101 kg)

Built-In – Narrow

Model [▲]	Watts	Amps [★]	No. of Drawers	Shipping Weight
HDW-1BN	450	3.8	One	88 lbs. (40 kg)
HDW-2BN	900	7.5	Two	159 lbs. (72 kg)
HDW-3BN	1350	11.3	Three	223 lbs. (101 kg)

Split Drawer

Model	Watts	Amps [★]	No. of Drawers	Shipping Weight
HDW-1R2	525	4.4	Two	97 lbs. (44 kg)

▲ 1-, 2-, and 3-drawer freestanding and split drawer units are standard with 4" (102 mm) legs; four drawer freestanding units with 6" (152 mm) stainless steel legs. Accessory 6" (152 mm) stainless legs, or 2" (51 mm), 3" (76 mm), or 5" (127 mm) diameter casters available on 1-, 2-, and 3-drawer units, or 4" (102 mm) diameter casters available on all units.

★ Based on 120 volts.

Dimensions

Freestanding – (Without legs or casters)

- HDW-1: 29½"W x 22⅝"D x 11"H (749 x 575 x 279 mm)
- HDW-1N: 20⅞"W x 27"D x 11"H (530 x 686 x 279 mm)
- HDW-2: 29½"W x 22⅝"D x 21⅞"H (749 x 575 x 537 mm)
- HDW-2N: 20⅞"W x 27"D x 21⅞"H (530 x 686 x 537 mm)
- HDW-3: 29½"W x 22⅝"D x 31¼"H (749 x 575 x 794 mm)
- HDW-3N: 20⅞"W x 27"D x 31¼"H (530 x 686 x 794 mm)
- HDW-4: 29½"W x 22⅝"D x 41⅜"H (749 x 575 x 1051 mm)

Built-In – (Excluding front mounting flange)

- HDW-1B: 28⅞"W x 22⅜"D x 9¾"H (714 x 568 x 248 mm)
- HDW-1BN: 19½"W x 26¾"D x 9¾"H (495 x 679 x 248 mm)
- HDW-2B: 28⅞"W x 22⅜"D x 20"H (714 x 568 x 508 mm)
- HDW-2BN: 19½"W x 26¾"D x 20"H (495 x 679 x 508 mm)
- HDW-3B: 28⅞"W x 22⅜"D x 30⅞"H (714 x 568 x 765 mm)
- HDW-3BN: 19½"W x 26¾"D x 30⅞"H (495 x 679 x 765 mm)

Split Drawer – (Without legs or casters)

- HDW-1R2: 29⅞"W x 16⅝"D x 10⅞"H (746 x 422 x 276 mm)

Built-In Cutout Requirements

Model	"W" Dimension	"D" Dimension*	"H" Dimension
HDW-1B	28¼" (718 mm)	23¾" (603 mm)	10⅞" (257 mm)
HDW-2B	28¼" (718 mm)	23¾" (603 mm)	20¼" (514 mm)
HDW-3B	28¼" (718 mm)	23¾" (603 mm)	30⅜" (772 mm)
HDW-1BN	19⅝" (498 mm)	28⅞" (714 mm)	10⅞" (257 mm)
HDW-2BN	19⅝" (498 mm)	28⅞" (714 mm)	20¼" (514 mm)
HDW-3BN	19⅝" (498 mm)	28⅞" (714 mm)	30⅜" (772 mm)

* Add 1½" (38 mm) for conduit connector.

Voltage

120 volts, single phase, freestanding, split 1-, 2-, 3-, and 4-drawer models use NEMA 5-15P. 4-drawer model not available for Canada. 208 and 240 volts available, freestanding models use NEMA 6-15P. Export voltages available (except HDW-1R2).

Cord Location

Back of unit, lower left corner.

Plug Configurations

FREESTANDING UNITS ONLY

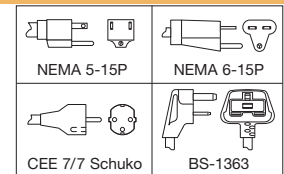

Unique Needs, Exact Solutions.

At Hatco we look, listen, and bring our full experience to your operation. "Customerization" is our brand promise...providing you with foodservice innovations that build your profits. That's Hatco, and that's always good for business.

Contact us today for all of your foodservice equipment needs.



Nothing less than the best.™

P.O. Box 340500
Milwaukee, WI 53234-0500 U.S.A.
(800) 558-0607 • (414) 671-6350
Fax (800) 543-7521
Int'l. Fax (414) 671-3976
www.hatcocorp.com
E-mail: equipmentsales@hatcocorp.com

