

## TECHNICAL DATA SHEET FOR Gas Range Static Oven 900mm CR9D, CR9C



CR9D

- 900mm wide
- Stainless steel finish
- 5.5kW (18,800Btu/hr) burners
- 4 or 6 open burner configuration
- Cast iron burners and vitreous enamel pot stands
- High crown static oven
- Capacity for one 2/1 GN or two 1/1 GN pans on each rack
- Manual pilot ignition
- French door system
- Welded vitreous enameled oven liner
- Griddle option – 300mm machine finished 12mm thickness, with piezo ignition
- Adjustable front feet and rear rollers
- Fully modular
- Flame failure protection on open burners

### Overall Construction

#### Cooktop

Cast iron open burner heads with vitreous enamelled cast iron caps

Vitreous enamelled potstands

12mm machined surface mild steel griddle plate

Stainless steel front, sides and splashback

Aluminised steel spill tray

Griddle sections are standard on RH side only.

#### Oven

Aluminised oven frame

Fully welded and vitreous enamelled oven liner

Extra wide GN 2/1 capacity with 4 position racking

Supplied with one chrome plated oven rack

Vitreous enamelled oven spill tray

Vitreous enamelled door inners

Stainless steel exterior doors and sides

50mm dia. stainless steel adjustable legs to front and two rollers at rear

### Controls

#### Cooktop

Large easy use control knobs

Variable high to low controls to open and griddle burners

Flame failure on open burners

Griddles standard with pilot, flame failure and piezo ignition

#### Oven

80-300°C thermostatic oven control

Manual ignition to oven pilot burner with flame failure

### Cleaning and Servicing

Easy clean stainless steel exterior

Vitreous enamelled potstands and burner caps

Lift off open burner caps and removable burners

Removable cooktop and oven spill trays

Stainless steel grease trays on griddles

Access to all parts from front of unit

## TECHNICAL DATA SHEET FOR Gas Range Static Oven 900mm CR9D, CR9C

### Burners

Open Burners;  
Natural Gas  
5.5kW, 18,800Btu/hr each  
LP gas  
5.0kW, 17,075Btu/hr each  
Griddle Burners;  
5.5kW, 18,800Btu/hr  
per 300mm section  
Oven; 8kW, 27,320Btu/hr

### Gas power (gross)

Natural Gas  
CR9D 41kW, 140,000Btu/hr  
CR9C 35.5kW, 121,240Btu/hr  
LP gas  
CR9D 38kW, 129,800Btu/hr  
CR9C 33.5kW, 114,400Btu/hr

### Oven Dimensions

Width 760mm  
Depth 615mm  
Height 365mm

### Rack size

750mm x 590mm  
Rack positions 4

### Gas connection

R $\frac{3}{4}$  (BSP) male  
130mm from RH side, 20mm from  
rear, and 655mm from floor

*All units supplied with Natural and  
LP gas regulator*

### Dimensions

Width 900mm  
Depth 800mm  
Height 915mm  
Incl. splashback 1085mm

### Packing data

1.02m<sup>3</sup>  
Width 940mm  
Depth 865mm  
Height 1255mm  
145kg nett weight  
210kg packed weight

### Gas types

Available in Natural gas and LP gas,  
please specify when ordering

*Other gas types on request*

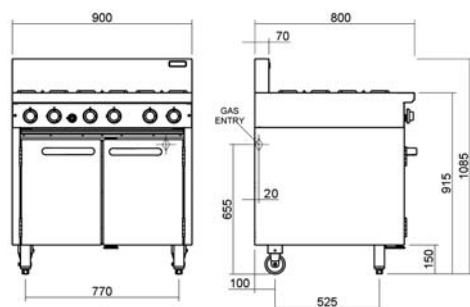

CR9

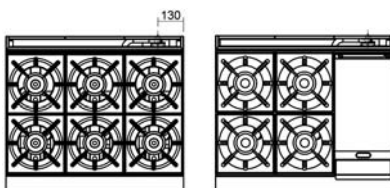

CR9D

CR9C



[www.blue-seal.co.uk](http://www.blue-seal.co.uk)

United Kingdom  
Blue Seal Limited

Unit 67  
Gravelly Business Park  
Gravelly  
Birmingham B24 8TQ  
England  
Ph 0121-327 5575  
Fax 0121-327 9711  
sales@blue-seal.co.uk  
www.blue-seal.co.uk

Australia  
Moffat Pty Limited

740 Springvale Road  
Mulgrave  
Victoria 3170  
Australia  
Ph 03-9518 3888  
Fax 03-9518 3833  
vsales@moffat.com.au  
www.moffat.com.au

New Zealand  
Moffat Limited

16 Osborne Street  
PO Box 10-001  
Christchurch 8011  
Ph 03-389 1007  
Fax 03-389 1276  
sales@moffat.co.nz  
www.moffat.co.nz



ISO9001  
Quality  
Management  
Standard

Designed and manufactured by



ISO9001

All Cobra products are designed and  
manufactured by Moffat using the  
internationally recognised ISO9001  
quality management system, covering  
design, manufacture and final  
inspection, ensuring consistent high  
quality at all times.



In line with policy to continually develop  
and improve its products, Moffat Limited  
reserves the right to change  
specifications and design without notice.

