

Gas Barbecue 900mm

CB9



OVERALL CONSTRUCTION

- Six 135mm wide x 550mm long reversible cast iron top grates
- Cast iron burner radiants and aluminised steel baffles
- Aluminised steel burners
- Stainless steel front, sides and splashback
- Stainless steel cabinet interior base
- Stainless steel grease tray
- 50mm dia. stainless steel adjustable legs to front and two rollers at rear

CONTROLS

- Large easy use control knobs
- Triple controls with variable high to low burner setting
- Pilot, flame failure and piezo ignition to each burner

CLEANING AND SERVICING

- Lift out radiants, burners and grease tray baffles
- Lift out stainless steel top grate and radiant supports
- Easy clean stainless steel exterior
- Access to all parts from front of unit

- 900mm wide
- Stainless steel finish
- Stainless steel grease tray
- Reversible top grates
- Inclined position to reduce flare and enhance grease run
- 3 x 9kW aluminised burners
- Flame failure protection with continuous pilot burner and piezo ignition
- Lift out grates, radiants and baffles for cleaning
- Open cabinet base for extra storage
- Adjustable front feet and rear rollers



Gas Barbecue 900mm

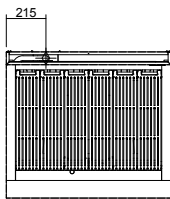
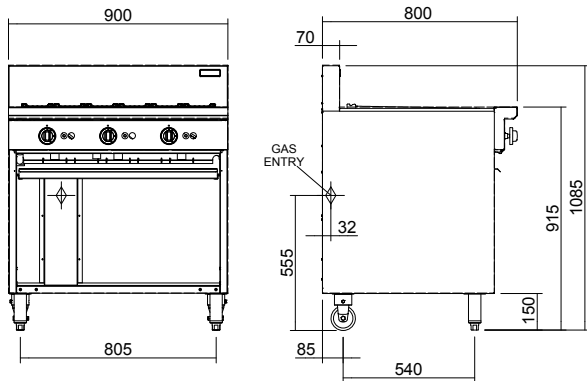

CB9

SPECIFICATIONS

Burners

3 x 9.8kW, 33,470Btu/hr U-burners

Gas power (gross)

29.4kW, 100,410Btu/hr

Cooking surface area

800mm x 540mm, 4320cm²

Gas connection

R 3/4 (BSP) male
215mm from LH side, 32mm from rear, and 555mm from floor
All units supplied with Natural and LP gas regulator

Dimensions

Width 900mm
Depth 800mm
Height 915mm
Incl. splashback 1085mm

Nett weight

135kg

Packing data

1.02m³, 200kg
Width 940mm
Depth 865mm
Height 1255mm

Gas types

Available in Natural gas and LP gas,
please specify when ordering
Other gas types on request



www.blue-seal.co.uk

United Kingdom

blue-seal.co.uk

Blue Seal Limited

Unit 67

Gravelly Business Park

Gravelly

Birmingham B24 8TQ

England

Telephone 0121-327 5575

Facsimile 0121-327 9711

sales@blue-seal.co.uk

Australia

moffat.com.au

Moffat Pty Limited

740 Springvale Road

Mulgrave

Victoria 3170

Australia

Telephone +613-9518 3888

Facsimile +613-9518 3833

vsales@moffat.com.au

New Zealand

moffat.co.nz

Moffat Limited

45 Illinois Drive

Izone Business Hub

Rolleston 7675

New Zealand

Telephone +64 3-983 6600

Facsimile +64 3-983 6660

sales@moffat.co.nz

International

moffat.com

international@moffat.co.nz



ISO9001
Quality
Management
Standard

Designed and manufactured by



ISO9001

All Cobra products are designed and manufactured by Moffat using the internationally recognised ISO9001 quality management system, covering design, manufacture and final inspection, ensuring consistent high quality at all times.

In line with policy to continually develop and improve its products, Moffat Limited reserves the right to change specifications and design without notice.



© Copyright Moffat Ltd
UK.C.SS.1701

an Ali Group Company



The Spirit of Excellence