

TECHNICAL DATA SHEET FOR Gas Barbecue 600mm

CB6



CB6

- 600mm wide
- Stainless steel finish
- Stainless steel grease tray
- Reversible top grates
- Inclined position to reduce flare and enhance grease run
- 2 x 9kW aluminised burners
- Flame failure protection with continuous pilot burner and piezo ignition
- Lift out grates, radiants and baffles for cleaning
- Open cabinet base for extra storage
- Adjustable front feet and rear rollers

Overall Construction

Four 135mm wide x 550mm long reversible cast iron top grates
Cast iron burner radiants and aluminised steel baffles
Aluminised steel burners
Stainless steel front, sides and splashback
Stainless steel cabinet interior base
Stainless steel grease tray
50mm dia. stainless steel adjustable legs to front and two rollers at rear

Controls

Large easy use control knobs
Dual controls with variable high to low burner setting
Pilot, flame failure and piezo ignition to each burner

Cleaning and Servicing

Lift out radiants, burners and grease tray baffles
Lift out stainless steel top grate and radiant supports
Easy clean stainless steel exterior
Access to all parts from front of unit

TECHNICAL DATA SHEET FOR Gas Barbecue 600mm CB6

Burners

2 x 9.8kW, 33,470Btu/hr U-burners

Gas power (gross)

19.6kW, 66,940Btu/hr

Cooking surface area

540mm x 500mm, 2700cm²

Gas connection

R1/2 (BSP) male

215mm from LH side, 32mm from rear, and 555mm from floor

All units supplied with Natural and LP gas regulator

Dimensions

Width 600mm

Depth 800mm

Height 915mm

Incl. splashback 1085mm

Packing data

0.70m³

Width 640mm

Depth 865mm

Height 1255mm

90kg nett weight

140kg packed weight

Gas types

Available in Natural gas and LP gas, please specify when ordering

Other gas types on request

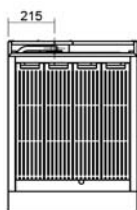
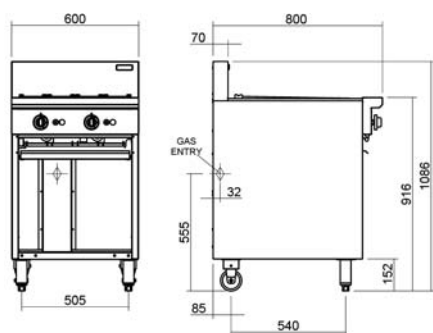

CB6

BLUE SEAL®

www.blue-seal.co.uk

United Kingdom
Blue Seal Limited

Unit 67
Gravelly Business Park
Gravelly
Birmingham B24 8TQ
England
Ph 0121-327 5575
Fax 0121-327 9711
sales@blue-seal.co.uk
www.blue-seal.co.uk

Australia
Moffat Pty Limited

740 Springvale Road
Mulgrave
Victoria 3170
Australia
Ph 03-9518 3888
Fax 03-9518 3833
vsales@moffat.com.au
www.moffat.com.au

New Zealand
Moffat Limited

16 Osborne Street
PO Box 10-001
Christchurch 8011
Ph 03-389 1007
Fax 03-389 1276
sales@moffat.co.nz
www.moffat.co.nz



ISO9001
Quality
Management
Standard

Designed and manufactured by

MOFFAT®

ISO9001

All Cobra products are designed and manufactured by Moffat using the internationally recognised ISO9001 quality management system, covering design, manufacture and final inspection, ensuring consistent high quality at all times.



In line with policy to continually develop and improve its products, Moffat Limited reserves the right to change specifications and design without notice.