



SKYLINE
FURNITURE
MFG.

KING / CALIFORNIA KING PLATFORM BED ASSEMBLY

For 1370BED, 1670BED, 1670BEDFC and 570BED Series

COMPONENTS

Please note: actual bed may look different than illustration.

ITEM	DESCRIPTION	QTY	ITEM	DESCRIPTION	QTY
A	Metal corners	4	E	Center support rail	3
B	Metal side rail	2	F	Center support leg	6
C	Metal end rail	2	G	Upholstered side rail	2
D	Wood leg	4	H	Upholstered foot rail	1
			I	Vertical support rail	1
			J	Wooden slat roll (located in headboard box)	2
			K	Headboard	1

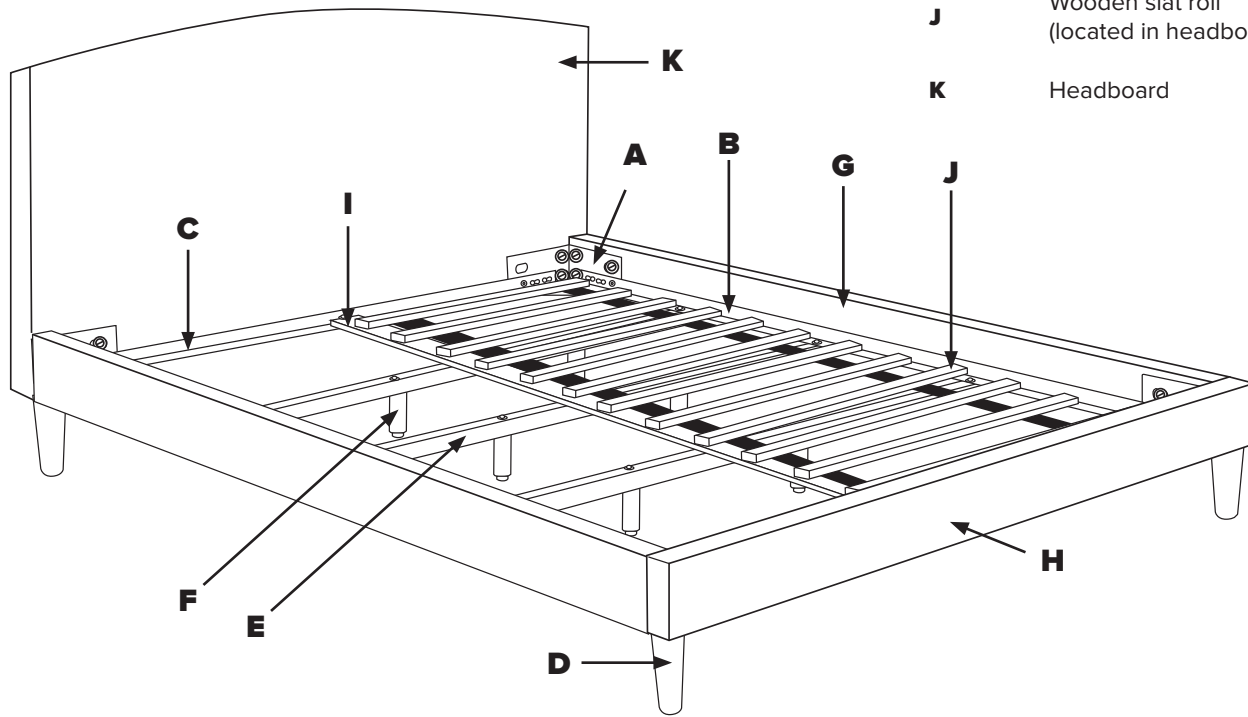

BED FRAME HARDWARE



(H1) x 14
1/4" bolt



(H2) x 27
1/4" nut



(H5) x 19
1" x 1/4" bolt



(H6) x 11
3/4" washer



(H8) x 26
1 1/4" washer



(H9) x 1
L wrench



(H11) x 1
Wrench



(H14) x 4
3" x 5/16" bolt



(H15) x 18
2" x 5/16" bolt

Please note: you will need a flat head screwdriver to assemble your bed frame. This assembly requires two people.



SKYLINE
FURNITURE
MFG.

KING / CALIFORNIA KING PLATFORM BED ASSEMBLY

For 1370BED, 1670BED, 1670BEDFC and 570BED Series

STEP 1 - BUILDING THE METAL BED FRAME

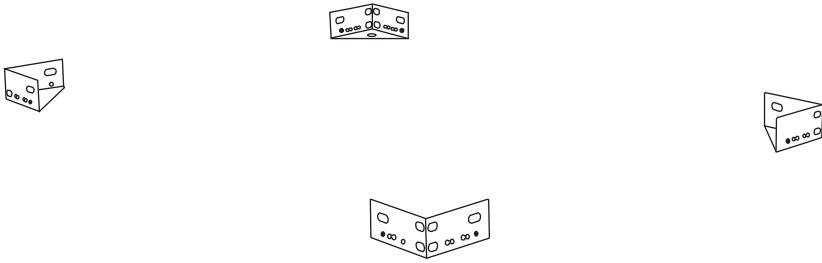

1.1

Place (A) metal corners in a rectangular shape roughly the size of your mattress.

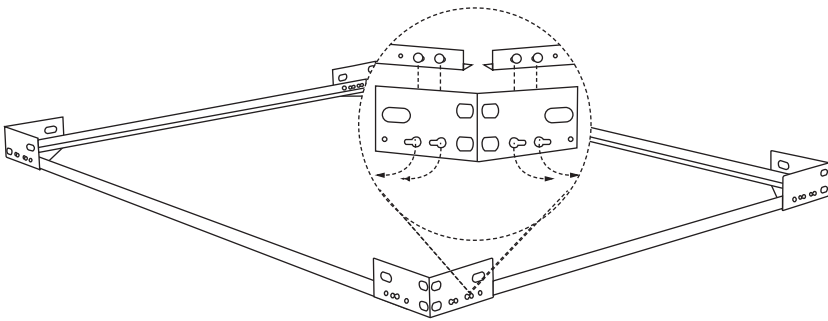

1.2

Lay (B) and (C) metal rails into (A) metal corners to create the shape of your bed frame. Snap into place.

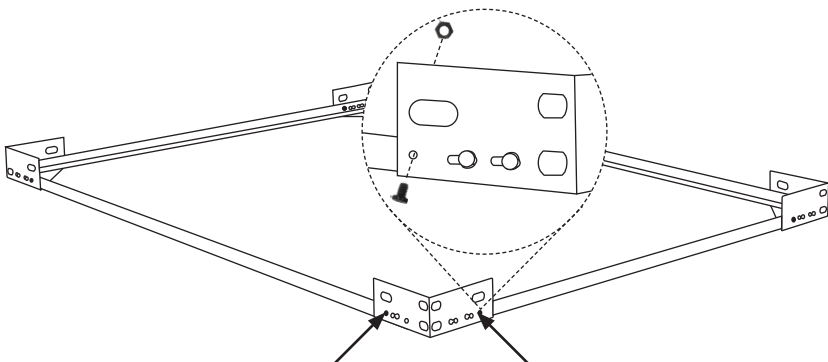

1.3

Secure (B, C) metal rails to (A) metal corners using (H1) bolts and (H2) nuts. Tighten using (H9) L wrench and (H11) wrench.

Please note: (H2) nuts should be on the inside of the frame.



STEP 2 - ATTACHING THE HEADBOARD AND UPHOLSTERED RAILS

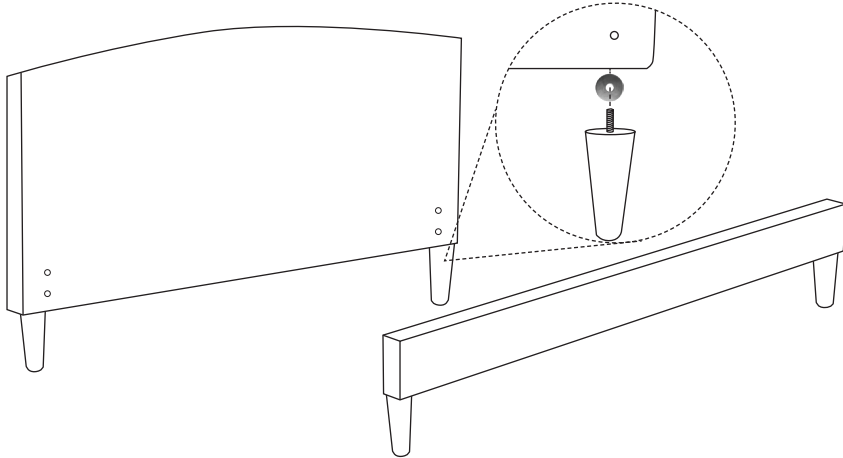

2.1
Attach (D) wood legs to (K) headboard and (H) upholstered foot rail using (H8) washer.

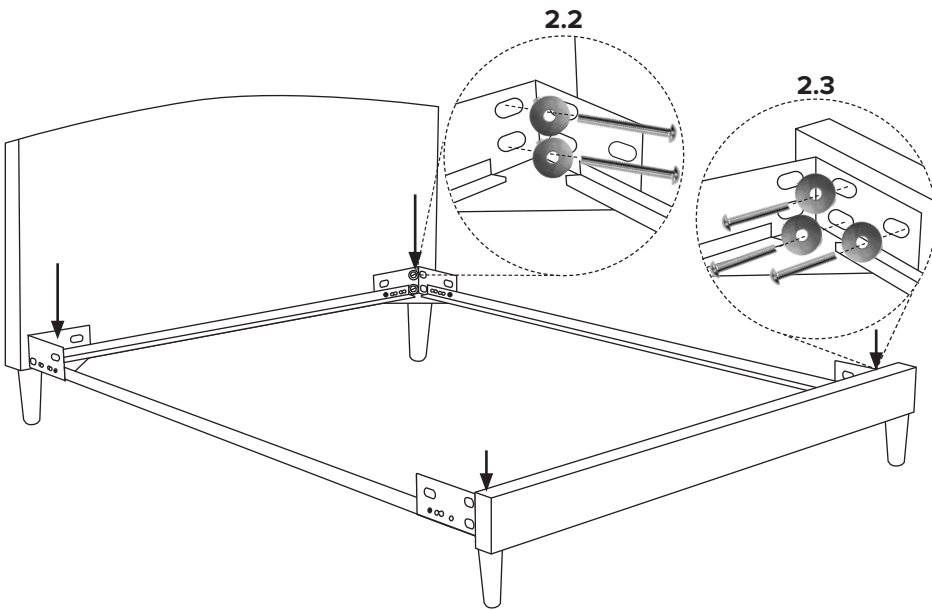

2.2
Loosely attach (K) headboard to the metal bed frame using (H14) bolts, (H8) washers and a flat head screwdriver.

2.3
Loosely attach (H) upholstered foot rail to the metal bed frame using (H15) bolts, (H8) washers and a flat head screwdriver.

Please note: we recommend one person hold the frame and upholstered pieces in place while a second person attaches the hardware.

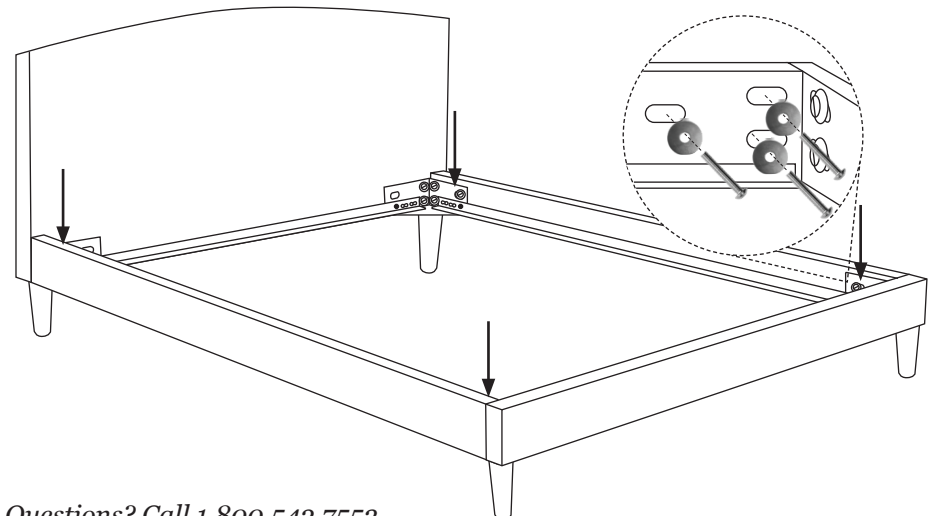

2.4
Loosely attach (G) upholstered side rails to the metal bed frame using (H15) bolts, (H8) washers and a flat head screwdriver.

Please note: do not tighten bolts until after both side rails have been attached.



STEP 3 - CENTER SUPPORT SYSTEM

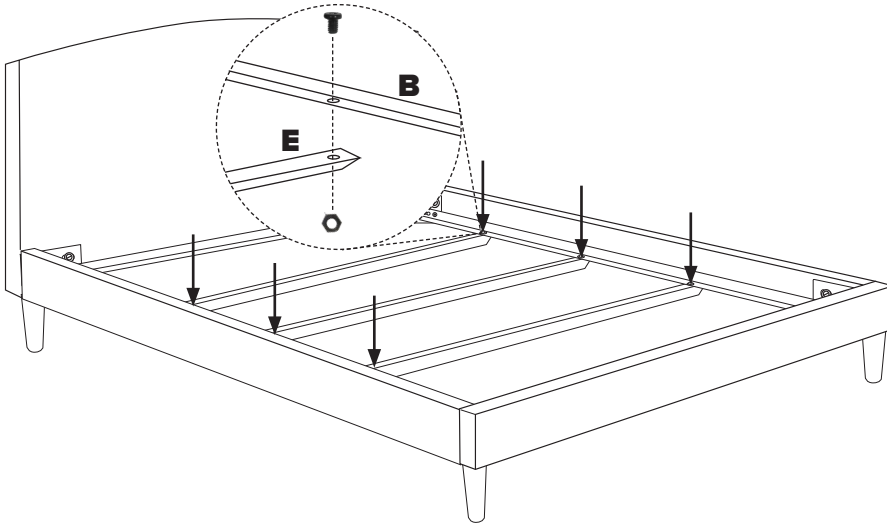

3.1

Align holes of (E) center support rail with holes on (B) metal side rails. Attach using (H1) bolts and (H2) nut. Tighten using (H9, H11) wrenches.

Please note: (E) center support rail attaches underneath (B) metal side rails.

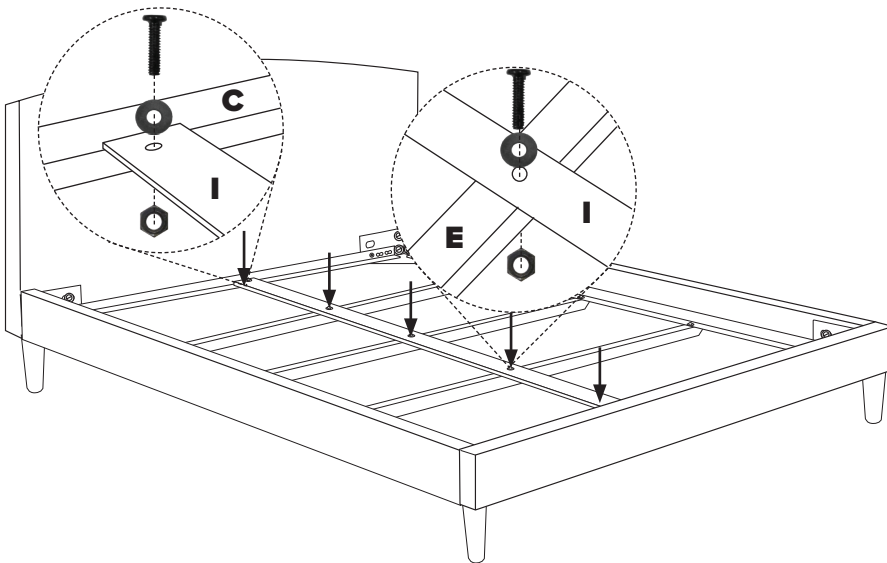

3.2

Align hole of (I) vertical support rail with holes on (C) metal end rail. Attach using (H5) bolts, (H6) washers and (H2) nuts. Tighten using (H9, H11) wrenches.

Attach (I) vertical support rail to (E) center support rails using (H5) bolts, (H6) washers and (H2) nuts. Tighten using (H9, H11) wrenches.

Please note: (I) vertical support rail attaches above (E) center support rail.

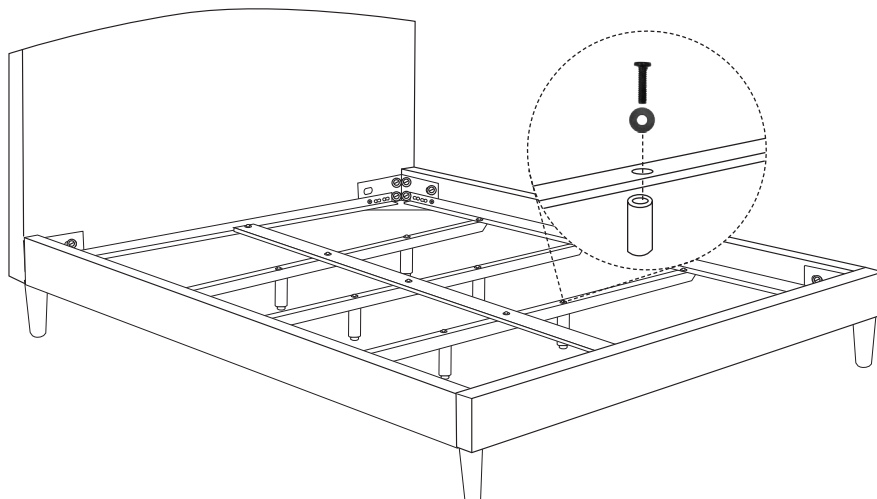

3.3

Attach (F) center support legs to (E, I) support rails using (H5) bolts and (H6) washers. Tighten using (H9) L wrench.

Please note: (F) center support legs can be adjusted in height by twisting the foot at the bottom of the leg.



SKYLINE
FURNITURE
MFG.

KING / CALIFORNIA KING PLATFORM BED ASSEMBLY

For 1370BED, 1670BED, 1670BEDFC and 570BED Series

STEP 3 - CENTER SUPPORT SYSTEM

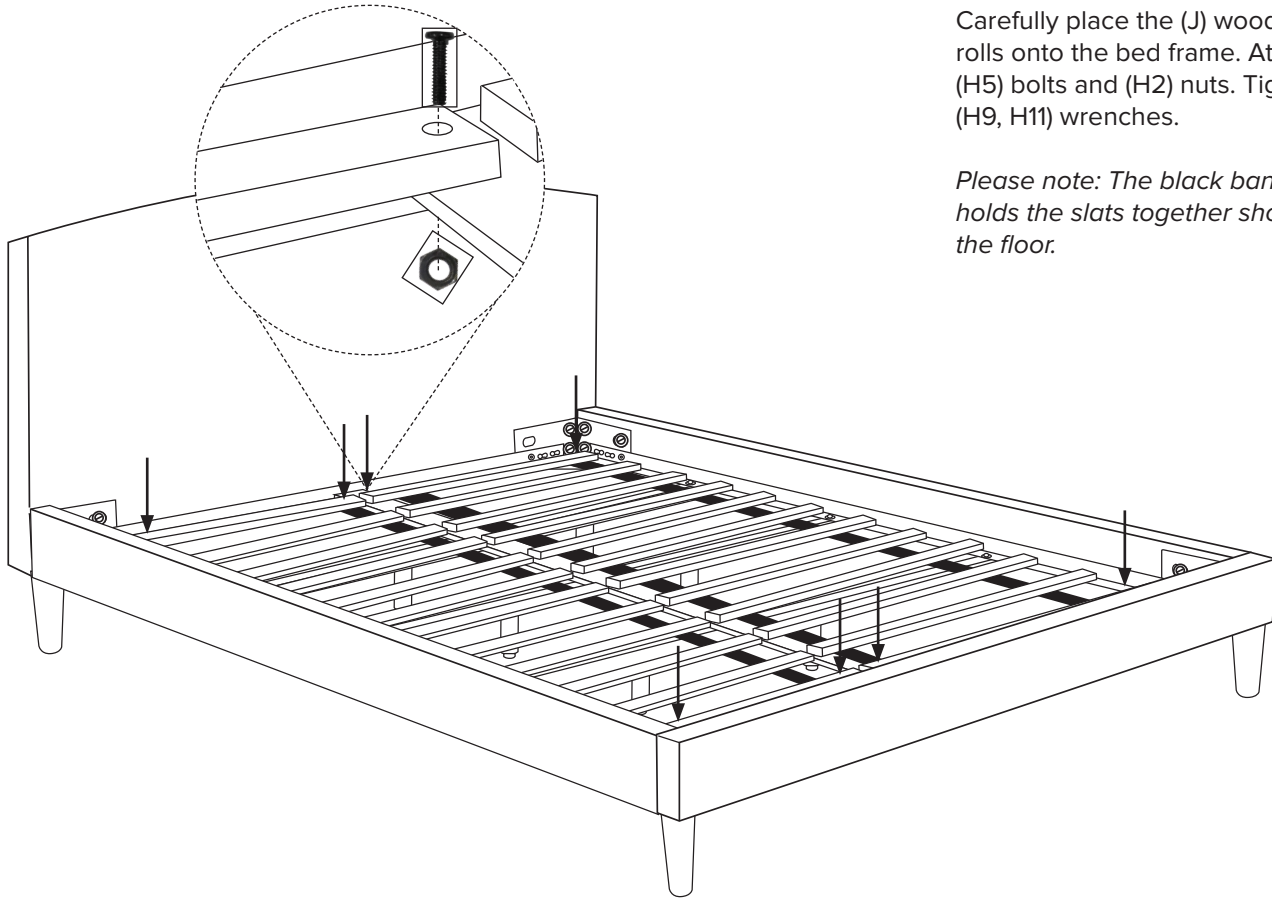

3.4

Carefully place the (J) wooden slat rolls onto the bed frame. Attach using (H5) bolts and (H2) nuts. Tighten with (H9, H11) wrenches.

Please note: The black band that holds the slats together should face the floor.

LIMITED WARRANTY

Skyline Furniture Inc. guarantees its upholstered furniture against defects in construction for a period of one (1) year. When a structural defect is brought to our attention, we will repair or replace it at our option at no charge to the customer (includes parts and labor, not transportation costs). Fabric wearability for upholstered furniture is not covered by the warranty. Vacuum for regular cleaning.

PLEASE DISPOSE OF PLASTIC BAG(S) AND CARTON(S) RESPONSIBLY.

LIMITE DE GARANTIA

Skyline Furniture Inc. garantiza sus muebles tapizados contra defectos en construcción por un periodo de un (1) año. Cuando un problema de estructura es traído a nuestra atención, nosotros repararemos o remplazaremos sin ningún cargo a nuestro cliente (incluye partes y trabajo, no costo en transportación). Descoloramiento del material de muebles tapizados no es cubierto por la garantía. Regularmente puede aspirar.

POR FAVOR TIRAR BOLSA(S) Y CAJA(S) RESPONSABLEMENTE.

GARANTIE LIMITÉE

Skyline Furniture Inc. garantit ses meubles rembourrés contre les défauts de construction pendant une période d'un (1) an. Lorsqu'un vice de construction nous est signalé, nous réparons ou remplaçons le meuble, selon notre choix, sans frais pour le client (incluant les pièces et la main-d'oeuvre, mais excluant les frais de transport). La durabilité du tissu des meubles rembourrés n'est pas couverte par la garantie. Nettoyer régulièrement avec un aspirateur.

VEUILLEZ JETER LE OU LES SAC(S) EN PLASTIQUE ET BOÎTE(S) DE FAÇON RESPONSABLE.