

HW-4P10S / 4PCSPXLT193

Four Post Parking Lift

Manual Release

Maximal Capacity: 10000 lbs.

Installation, Operation and Parts Manual

Distributed by

Please read this entire manual carefully and completely before installation or operation of the lift.

DATE: 28/10/2020

SAFETY	2
1.1 Operation of lifting platforms	2
1.2 Checking of the lifting platforms	2
1.3 Important safety notices	3
1.4 Potential risks and safety measures	4
PACKING AND TRANSPORTATION	5
2.1 Packing	5
2.2 Storage	5
2.3 Lifting and handling	6
PRODUCT DESCRIPTIONS	6
3.1 General descriptions	6
3.2 General construction of the lift	7
3.3 Dimensions	7
3.4 Safety devices descriptions	9
3.5 Technical data	9
INSTALLATION INSTRUCTIONS	10
4.1 Preparations before installation	10

4.2 Installation attentions.....	11
4.3 General installation instructions.....	12
4.4. Items to be checked after installation.....	20
OPERATION INSTRUCTIONS.....	20
5.1 Precautions.....	20
5.2 Operation instructions.....	20
TROUBLE SHOOTING.....	21
MAINTENANCE.....	22
Annex 1, Electrical schemes and parts list.....	24
Annex 2, Hydraulic schemes and parts list.....	26
Annex 3, Mechanical exploded drawings and parts list.....	31

SAFETY

1.1 Operation of lifting platforms

This lift is specially designed for vehicle parking. Users are not allowed to use it for any other purposes. The applicable national regulations, laws and directives must be observed.

Only users aged 18 or above who have been instructed on how to operate the lifting platform and have proven their ability to do so to the owner are to be entrusted with unsupervised operation of lifting platforms. The task of operating the lifting platforms must be granted in writing.

Before loading a vehicle onto the lifting platform, users should study the original operation instructions and familiarize themselves with the operating procedures in several trial runs.

Lift vehicle within the rated load. Don't attempt to park vehicles with excessive weight.

1.2 Checking of the lifting platforms

Checks are to be based on the following directives and regulations:

- Basic principles for testing lifting platforms
- The basic health and safety requirements

- Harmonized European standards
- The applicable accident prevention regulations

The checks are to be organized by the user of the lifting platform. The user is responsible for appointing an expert or qualified person to perform checking. It must be ensure that the person chosen satisfies the requirements.

The user bears special responsibility if employ s of the company are appointed as experts or qualified persons.

1.2.1 Scope of checking

Regular checking essentially involves performing a visual inspection and a functional test. This includes checking the condition of the components and equipment, checking that the safety systems are complete and functioning properly and that the inspection log book is completely filled in. The scope of exceptional checking depends on the nature and extent of any structural modification or repair work.

1.2.2 Regular checking

After initial commissioning, lifting platforms are to be checked by a qualified person at intervals of not longer than one year.

A qualified person is somebody with the training and experience required to possess sufficient knowledge of lifting platforms and who is sufficiently familiar with the pertinent national regulations, accident prevention regulations and generally acknowledged rules of engine ring to be able to assess the safe operating condition of lifting platforms.

1.2.3 Exceptional checking

Lifting platforms with a lift height of more than 2 meters and lifting platforms intended for use with people standing under the load bearing elements of the load are to be checked by an expert prior or reuse following structural modifications and major repairs to load bearing components.

An expert is somebody with the training and experience required to possess specialist knowledge of lifting platforms and who is sufficiently familiar with the pertinent national work safety regulations, accident prevention regulations and generally acknowledged rules of engineering to be able to check and give an expert option on lifting platforms.

1.3 Important safety notices

1.3.1 Recommend for indoor use only. DO not expose the lift to rain, snow or excessive moisture.

1.3.2 Only use this lift on a surface that is stable, level and dry and not slippery, and capable of sustaining the load. Do not install the lift on any asphalt surface.

1.3.3 Read and understand all safety warnings before operating the lift.

1.3.4 Do not leave the controls while the lift is still in motion.

1.3.5 Keep hands and feet away from any moving parts. Keep feet clear of the lift when lowering.

1.3.6 Only these properly trained personnel can operate the lift.

1.3.7 Do not wear unfit clothes such as large clothes with flounces, tires, etc., which could be caught by moving parts of the lift.

1.3.8 To prevent evitable incidents, surrounding areas of the lift must be tidy and with nothing unconcerned.

1.3.9 The lift is simply designed to lift the entire body of vehicles, with its maximum weight within the lifting capacity.

1.3.10 Always ensure the safety locks are engaged before any attempt to work near or under the vehicle. Never remove safety related components from the lift. Do not use if safety related components are damaged or missing.

1.3.11 Do not rock the vehicle while on the lift or remove any heavy component from vehicle that may cause excessive weight shift.

1.3.12 Check at any time the parts of the lift to ensure the agility of moving parts and the performance of synchronization. Ensure regular maintenance and if anything abnormal occurs, stop using the lift immediately and contact our dealers for help.

1.3.13 Lower the lift to its lowest position and do remember to cut off the power when not using the lift.

1.3.14 Do not modify any parts of the lift without manufacturer's advice.

1.3.15 If the lift is going to be left unused for a long time, users are required to:

- a. Disconnect the power;
- b. Empty the oil tank;
- c. Lubricate the moving parts with hydraulic oil.

WARNING: The warnings, cautions and instructions discussed in this instruction manual cannot cover all possible conditions and situations that may occur. It must be understood by the operator that common sense and caution are factors which cannot be built into this product, but must be supplied by the operator.

CAUTION1: *ALWAYS ensure the mechanical safety locks are engaged parking. Never remove safety related components from the lift. Do not use if safety related components are damaged or missing.*

CAUTION2: *Failure installation and operation or any improper modification could result in hurts or even death of operators. Please do read and understand this manual thoroughly and operate as it required.*

1.4 Potential risks and safety measures

1.4.1 RISK OF CRUSHING

Safety measures:

- During lift functioning, the operator must remain at the control station
- The presence of persons beneath the crossbeams and/or the platforms when they are moving, or the presence of persons inside the danger zone indicated in the following figure is strictly prohibited.
- During operations persons are admitted to the area beneath the vehicle only when the vehicle is already in the elevated position, when the crossbeams and platforms are stationary, and when the mechanical safety devices are engaged
- When the platforms (and vehicle) are lowering the operator must never be partly or completely underneath or near of the movable structure.
- The lift operator must not start the lift until it has been clearly established that there are no persons in danger zone.

1.4.2 RISK OF IMPACT

Caused by the parts of the lift or the vehicle that are positioned at head height.

Safety measure:

Personnel must be careful to avoid impact with parts of the machine not marked with special colors.

1.4.3 RISK OF VEHICLE MOVING

Caused by operations involving the application of force sufficient to displace the vehicle.

In the case of large or particularly heavy vehicles, sudden movement could create an unacceptable overload or uneven load sharing.

Safety measure:

Make sure that the vehicle is properly stopped by the hand brake before being raised.

1.4.4 RISK OF VEHICLE FALLING FROM LIFT

This hazard may arise in the case of incorrect positioning of the vehicle on the platforms, incorrect stopping of the vehicle, or in the case of vehicles of dimensions that are not compatible with the capacity of the lift.

Safety measure:

Check the vehicle after raising a short distance to ensure that it is correctly and safely positioned.

1.4.5 RISK OF SLACKENING OF LIFT CABLES

Caused by objects left leaning against the posts or on the platforms.

Safety measure:

Inspect the space above and below the load and the loading carrying devices. It shall be free of obstructions before operating.

1.4.6 RISK OF SLIPPING

Caused by lubricant contamination of the floor around the lift.

Safety measure:

The area beneath and surrounding the lift and also the platforms must be kept clean. Remove any oil spills immediately.

PACKING AND TRANSPORTATION

Packing, lifting, handling, transporting operations must be performed only by experienced personnel with appropriate knowledge of the lift and after reading this manual.

2.1 Packing

The lift is shipped with two parts.

<i>Name</i>	<i>Packed by</i>	<i>Dimension</i>	<i>Weight</i>	<i>Quantity</i>
<i>Lift</i>	<i>Steel bracket</i>	<i>198-13/16" x 24-7/16" x26 -15/16"</i>	<i>2530 lbs.</i>	<i>1</i>
<i>oil drip pans</i>	<i>Bubble film</i>	<i>37-3/8" x 23-5/8" x 2-3/8"</i>	<i>11 lbs.</i>	<i>1 (8 pcs)</i>

2.2 Storage

The packs must be kept in a covered and protected area in a temperature range of -10°C to +40°C. They must not be exposed to direct sunlight.

Stacking the packs

We advise against stacking because the packs are not designed for this type of storage. The narrow base, heavy weight and large size of the packs make stacking difficult and potentially dangerous.

If stacking is unavoidable, use all appropriate precautions:

-never stack to more than 2 meters (78 3/4") in height.

-never make stacks of single packs. Always stack pairs of packs in a cross pattern so that the base is bigger and the resulting stack is more stable. Once the stack is complete, restrain it using straps, ropes or other suitable methods.

A maximum of two packs can be stacked on lorries, in containers, and in railway wagons, on condition that the packs are strapped together and restrained to stop them falling.

2.3 Lifting and handling

The packs can be lifted and transported only by using lift trucks. Never attempt to hoist or transport the unit using lifting straps.

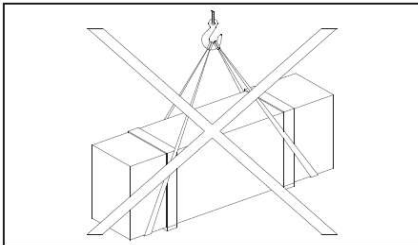

Opening the packs

When the lift is delivered make sure that it has not been damaged during transportation and that all the parts specified on the packing list are present.

Packs must be opened adopting all the precautions required to avoid injury to persons (keep at a safe distance when cutting the straps) or damage to parts of the machine (be careful that no parts are dropped while you are opening the packing)

Take special care with the hydraulic power unit, the control panel and the platform cylinder.

PRODUCT DESCRIPTIONS

3.1 General descriptions

This is wheel support vehicle parking lift. It is generally composed by four posts, two beams, two platforms, a hydraulic oil cylinder and a set of power unit. Being powered by an electro-hydraulic system, up and down movement is controlled by the to and fro movement of the oil cylinder. To ensure safety for operators, it is equipped with mechanical safety locks in four posts, which automatically engages in case of hydraulic failure.

3.2 General construction of the lift

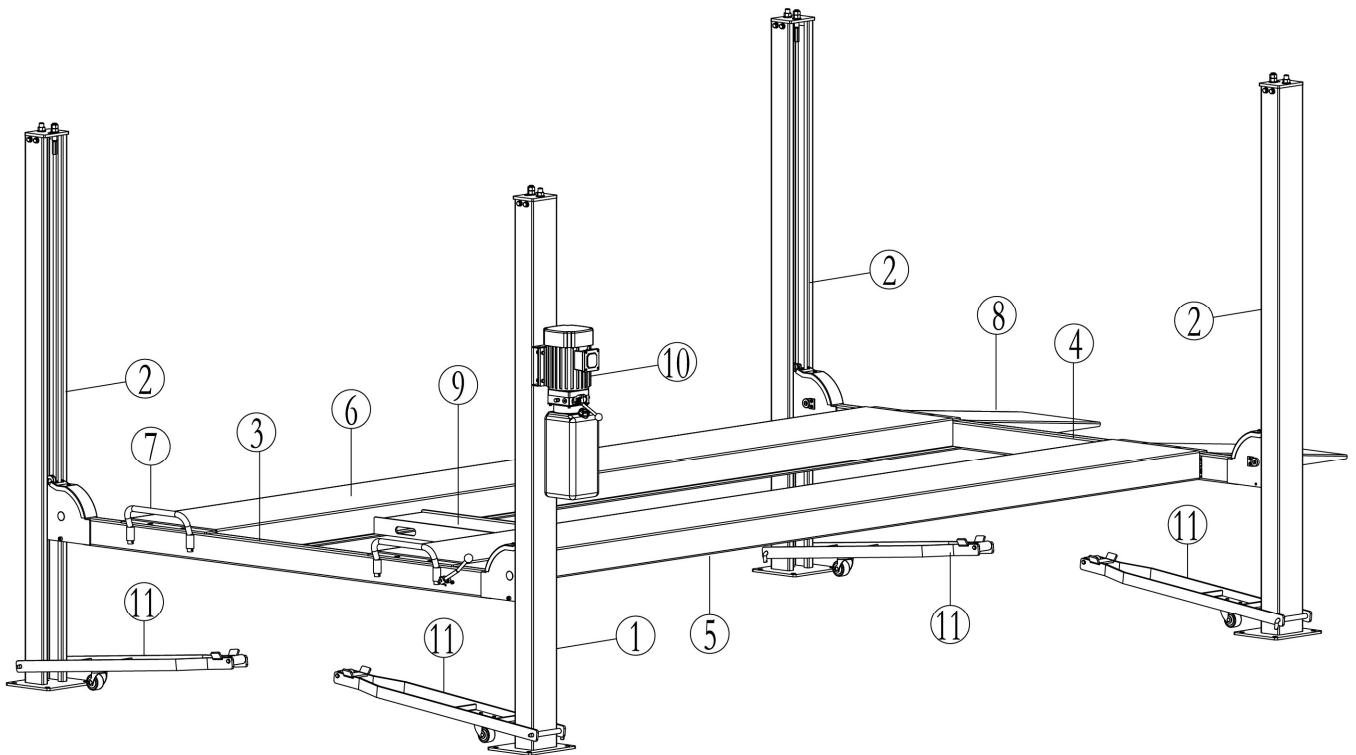

- | | |
|----------------------------|---------------------------|
| 1. Power side post | 7. Wheel stop |
| 2. Post | 8. Drive-on ramp |
| 3. Power side crossbeam | 9. Tool tray |
| 4. The secondary crossbeam | 10. Power unit |
| 5. Main platform | 11. Mobile kit (optional) |
| 6. Secondary platform | |

3.3 Dimensions

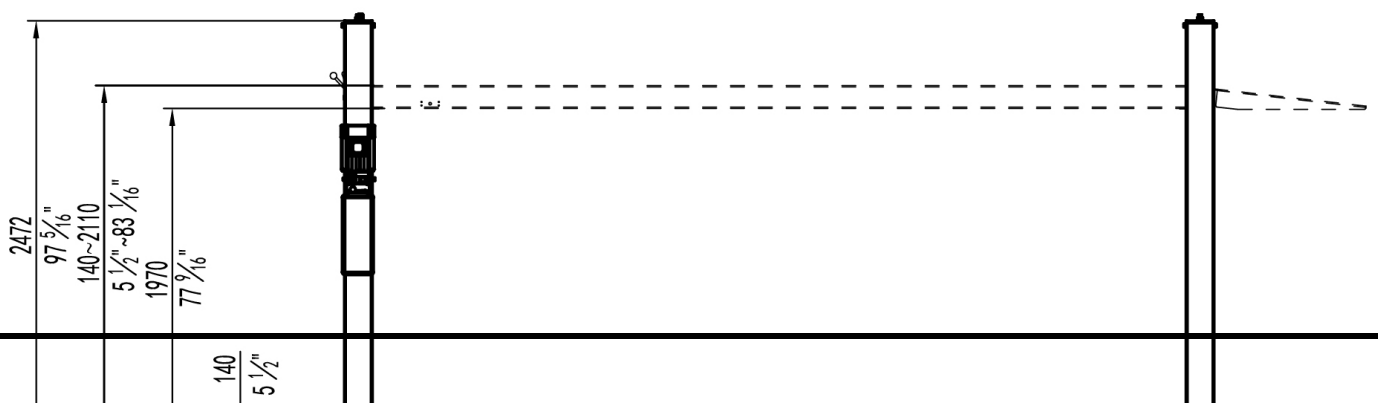

3.4 Safety devices descriptions

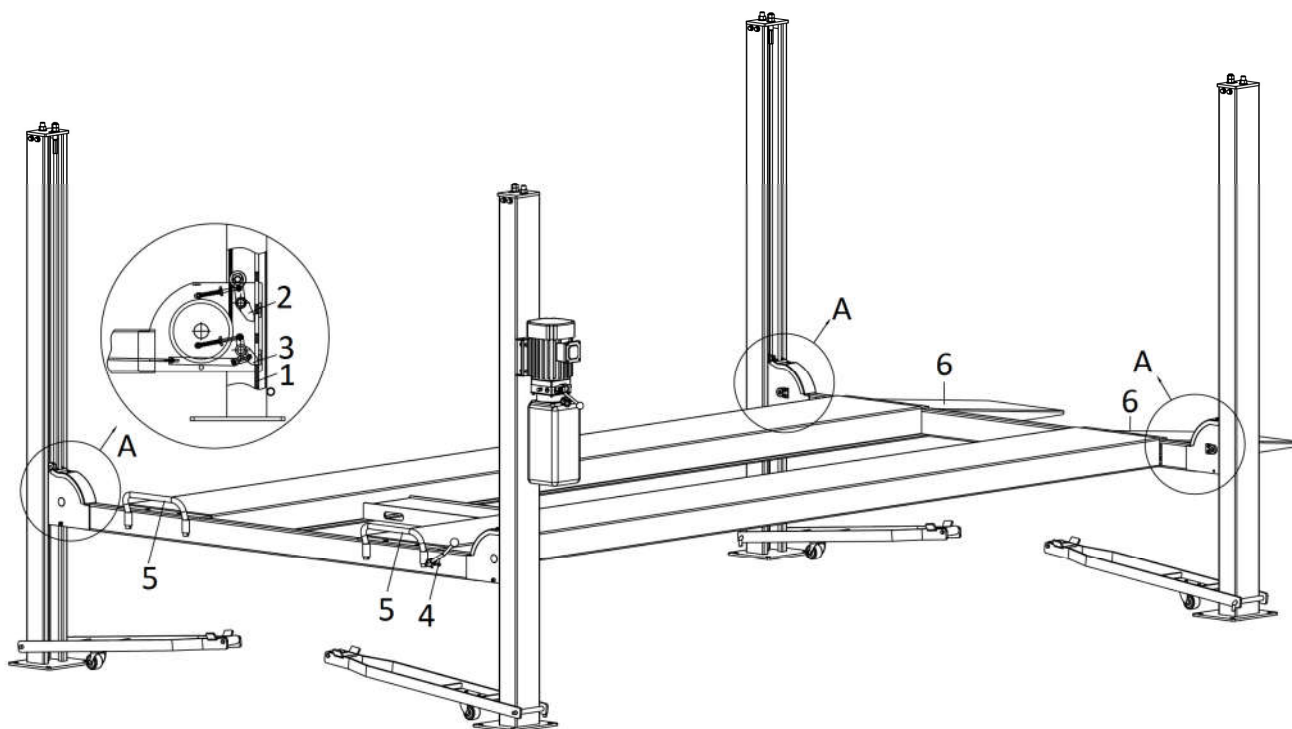

POS.	Description	Function
1-2-3	Mechanical safety locking unit	Catch the carriages in case of hydraulic failure
4	Manual locking release unit	Release mechanical safety lock manually.
5	Front end stops	Prevent vehicles from rolling off.
6	Rear end stops	Prevent vehicles from rolling off.

3.5 Technical data

Power type	Electro-hydraulic
Maximal Capacity	10000 lbs.
Full rise height	77 9/16"
Initial height	5 1/2"
Full rise time	Approx. 55s
Full descent time	Approx. 40s
Working pressure	About 2300psi
Power supply	380V /220V
Motor capacity	2.2kW
Oil tank volume	3.17 US gal
Noise	< 75dB(A)

INSTALLATION INSTRUCTIONS

4.1 Preparations before installation

4.1.1 Space requirements.

This lift is for indoor use only.

To stop vehicles colliding with the ceiling, it is advisable to fit an overhead light barrier in low ceiling buildings.

Refer to 3.3 for the dimensions of the lift. There must be a clearance of at least 1000mm (39 3/8") between the lifting platform and fixed elements (e.g. wall) in all lifting positions. There must be sufficient space at the ends of the lifting platform for driving vehicles on and off.

4.1.2 Foundations and connections

The user must have the following work performed before erecting the lift.

- Construction of the foundation following consultation with the manufacturer's customer service or an authorized service agent.
- Routing of the wiring to the installation location. The user must provide fuse protection for the connection. **For Voltage between 100V to 240V, it is advised to use C32 circuit breaker. For Voltage between 380V to 415V, it is advised to use C16 circuit breaker. Electrical system connection must be done by qualified electricians.**
- Refer also to the corresponding information in the operation instructions.

4.1.3 Foundations preparations

To ensure stability and safety under load, the lift shall be installed with the base frame being in direct and firm contact with the concrete foundation. Don't attempt to fix the base frame directly onto floor with ceramic and other decorated surfaces otherwise you put the lift into a very dangerous situation.

There must also be sufficient space for driving vehicles on and off.

C20/25 concrete base with a minimum thickness of 200mm (7-7/8").

Surface under each post: Horizontal and even (Gradients max. 0.5 %)

Newly built concrete ground must be older than 20days.

4.1.4 Tools and equipment needed for installation

Tool name	Specification	Quantity
Open spanner	D17-19, D22-24	2
Hex socket spanner	D2.5-14	1
Adjustable spanner	Above D30	1
Cross socket screw driver	PH2	1
Socket spanner	D24	1
Torque spanner	MD400	1
Levelling device	Accuracy 1/16"	1
Truck lift	Capacity not less than 3300 lbs.	1
Strap	Capacity not less than 3300 lbs.	1

4.1.5 Checking parts

Unfold the package and check if any parts missed as per the following list. Do not hesitate to contact us in case any parts missed.

S/N	Name	Qty	NOTE
1	Main lifting platform	1	Package 1
2	Secondary lifting platform	1	
3	Power side post	1	
4	Post	3	
5	Power side crossbeam	1	
6	Secondary crossbeam	1	
7	Wheel retaining tube	2	
8	Protective cover	4	
9	Drive-on ramp	2	
10	Tool tray	1	
11	Power unit	1	
12	Oil hose	1	
13	Expansion bolt M18*160	16	
14	Hex head full swivel screw M12*25	16	
15	Hex socket flat head screw M12*25	8	
16	Hex head full swivel screw M8*20	4	
17	Spring washer Φ 12	16	
18	Spring washer Φ 8	4	
19	Flat washer Φ 8	4	
20	Anti-shock pad	4	
21	User's Manual 6435E.V2	1	
22	Oil dip tray	8	Package 2

4.2 Installation attentions

4.2.1 Joints of oil hose and wiring must be firmly connected in order to avoid leakage of oil hose and looseness of electrical wires.

4.2.2 All bolts should be firmly screwed up.

4.2.3 Do not place any vehicle on the lift in the case of trial running.

4.3 General installation instructions

ONLY TRAINED AND QUALIFIED INSTALLERS CAN PERFORM LIFT INSTALLATION DUTIES.

Step 1: Fix the installation layout.

Mark the four standing points of the four posts on the installation site by a tape measure and chalk. Ensure two diagonal lines are of the same length.

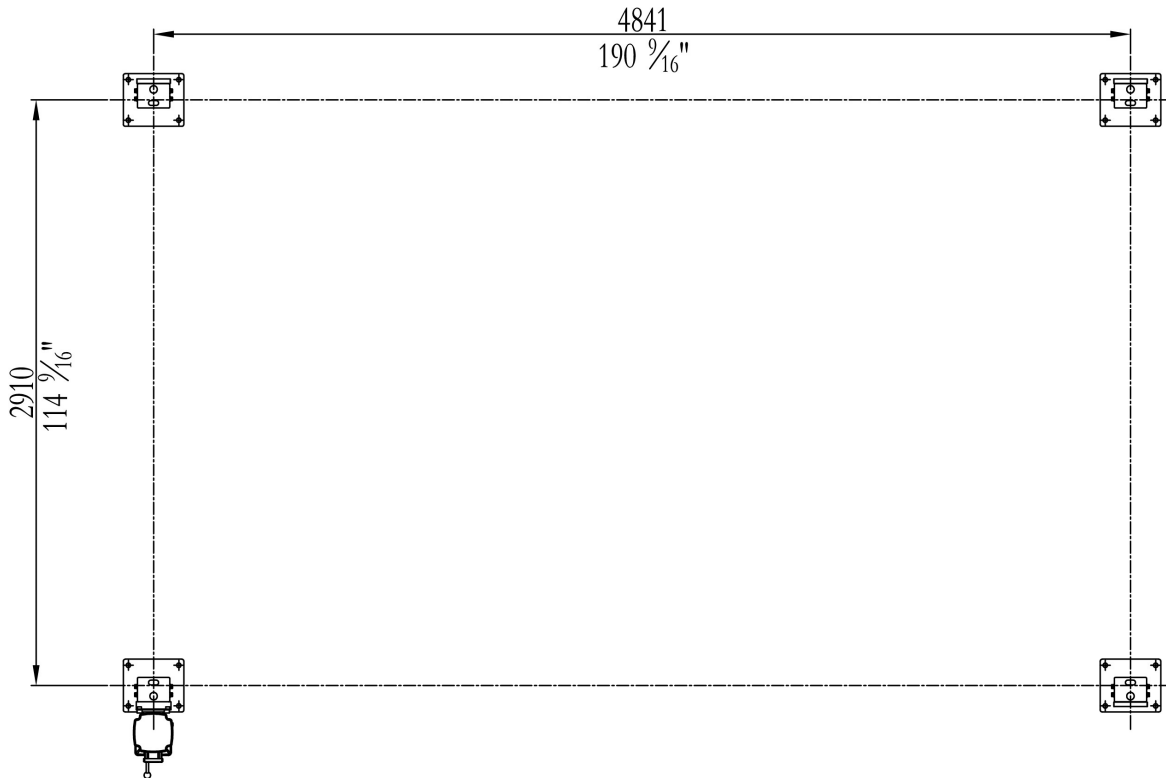

Step 2: Remove the packing materials.

Attention: Packs must be opened adopting all the precautions required to avoid injury to persons (keep at a safe distance when cutting the straps) or damage to parts of the machine (be careful that no parts are dropped while you are opening the packing)

Take special care with the hydraulic power unit, the power unit and the platform cylinder.

Avoid scratching the painting surface and hoses.

1. Place some wooden battens (thickness of which should be more than 80mm) on the ground (other dependable devices may also applicable) and then use forklift to have the packing rack removed on to the battens.
2. Have the platforms of the lift suspended by the forklift and then screw off the upside bolt and remove the first platform on to the wooden battens initially prepared.
3. Screw off the downside bolt and take away the packing racks on both sides.
4. Remove the shock absorption plastic film with a knife.

Step 3: Use the forklift to have the general parts properly positioned.

For convenient installation, it would be better to pad something supporting under the platform.

Oil cylinder, steel cable and oil hose have already been fixed in the power side platform (platform with oil cylinder beneath) before packing.

Step 4: Connect the platforms and beams.

1. Place the two post face to face with a distance of 3070mm and then push in the crossbeam from the top of the posts.
2. Erect the posts after both crossbeams are connected.

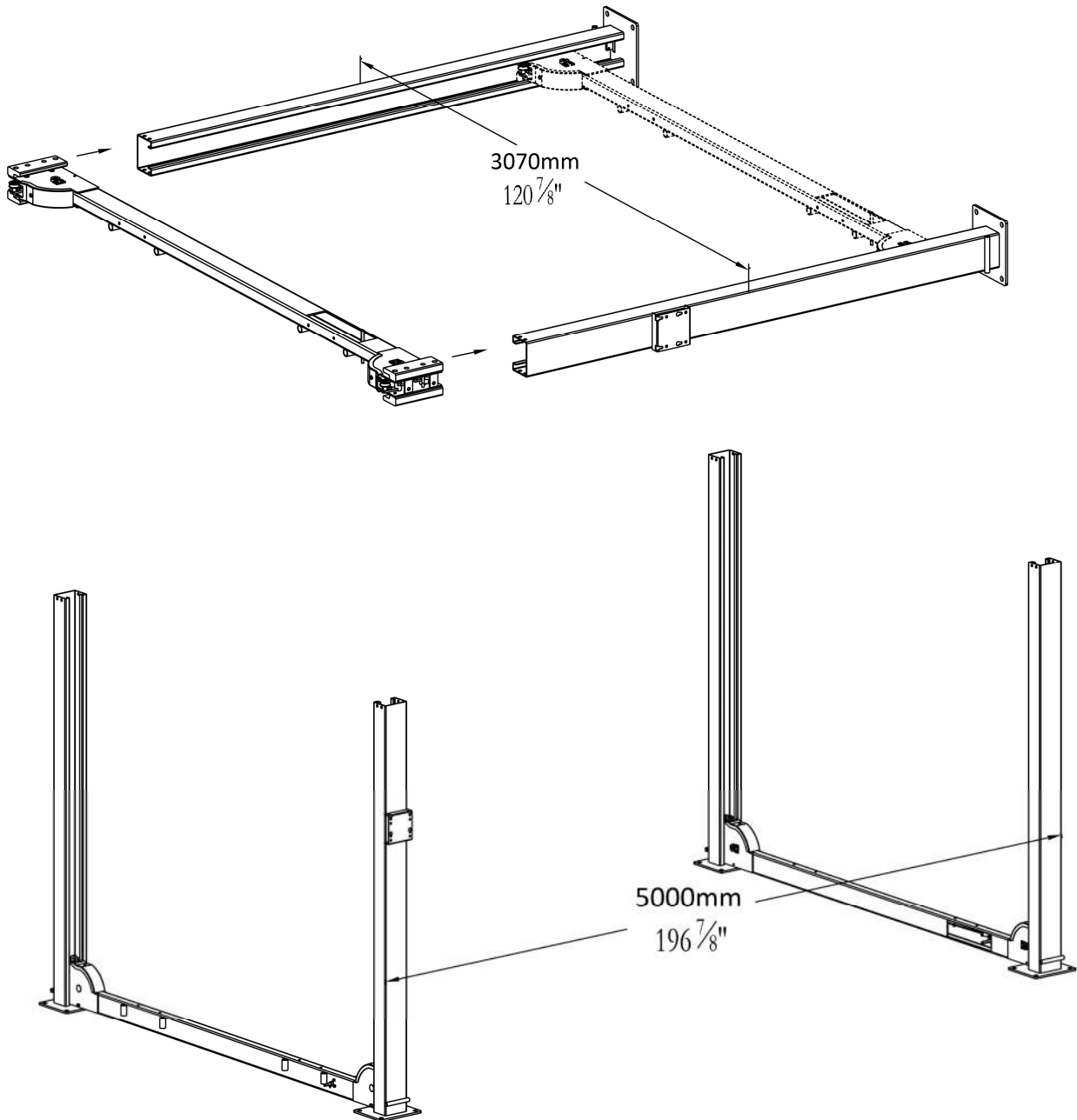

Step 5: Mount on the top post plate and fix safety ratchets.

1. Fix ratchet with the top post plate with M20 hex nut and flat washer. Ensure the four safety ratchets are of the same height from the ground. This could be checked by measuring the distance of the lowest square hole reserved on the ratchet and the floor.
2. Fix the top post plate with the post using M12*25 hex head screw, spring washer and flat washer.

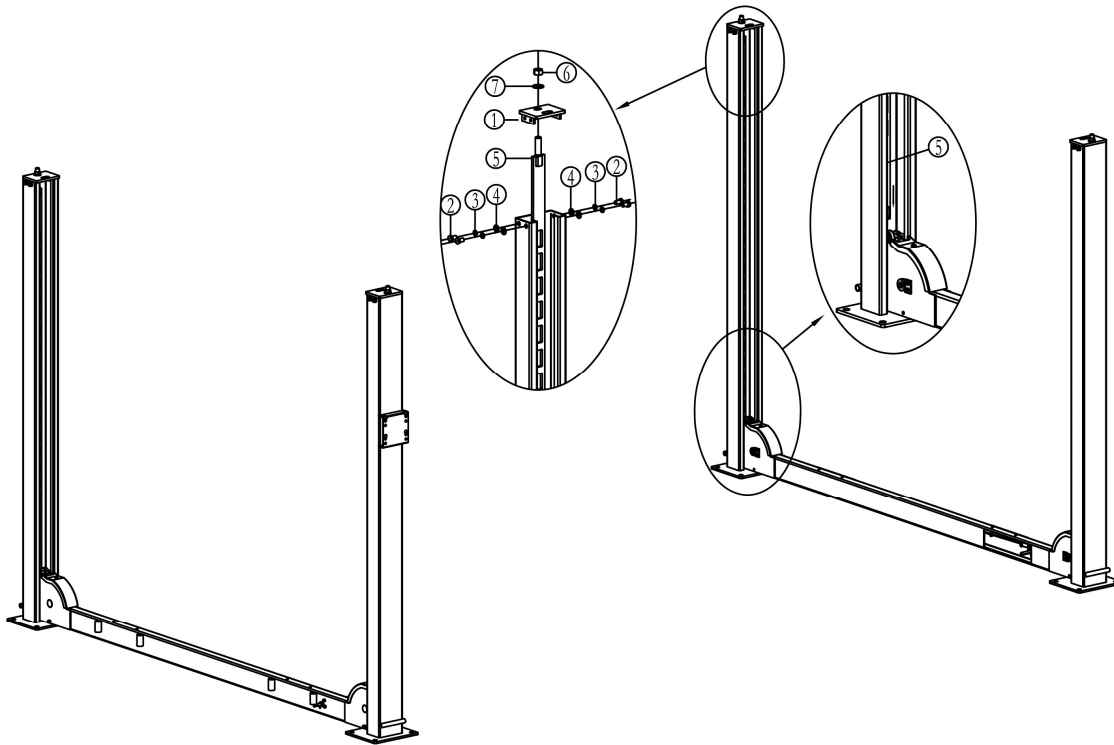

- ① Top post plate; ② M12*25 hex screw; ③ φ12 spring washer; ④ φ12 flat washer; ⑤ safety ratchet; ⑥ M20 nut; ⑦ φ20 flat washer

Step 6: Mount on lifting platforms

1. Raise both crossbeams to the first locking points.

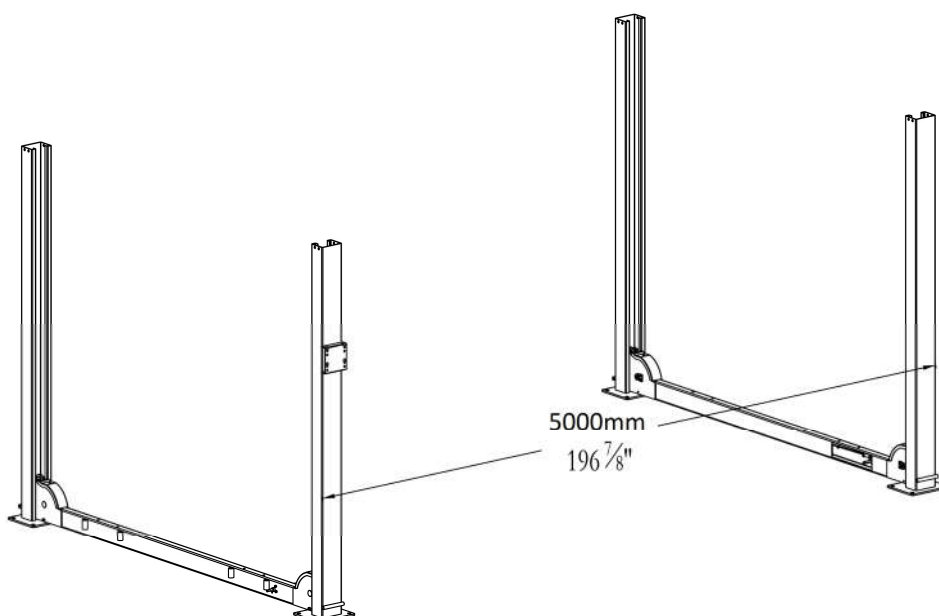

2. Lift the platform with proper lifting equipment and place it onto the crossbeams. Fix the lifting platform and the crossbeam with M12*25 hex socket flat head screw.

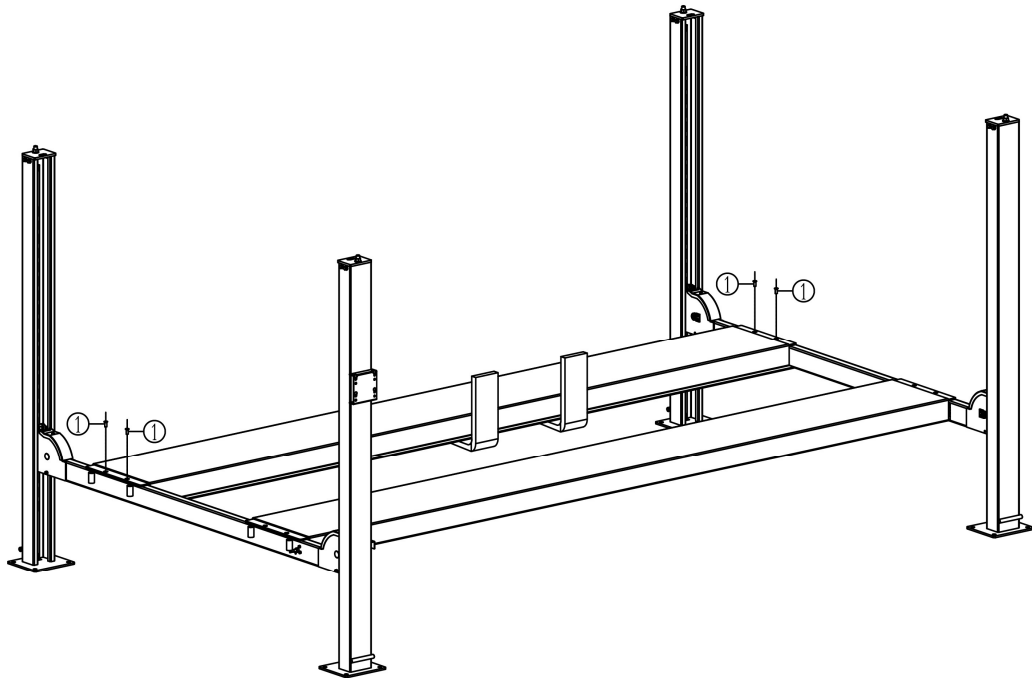
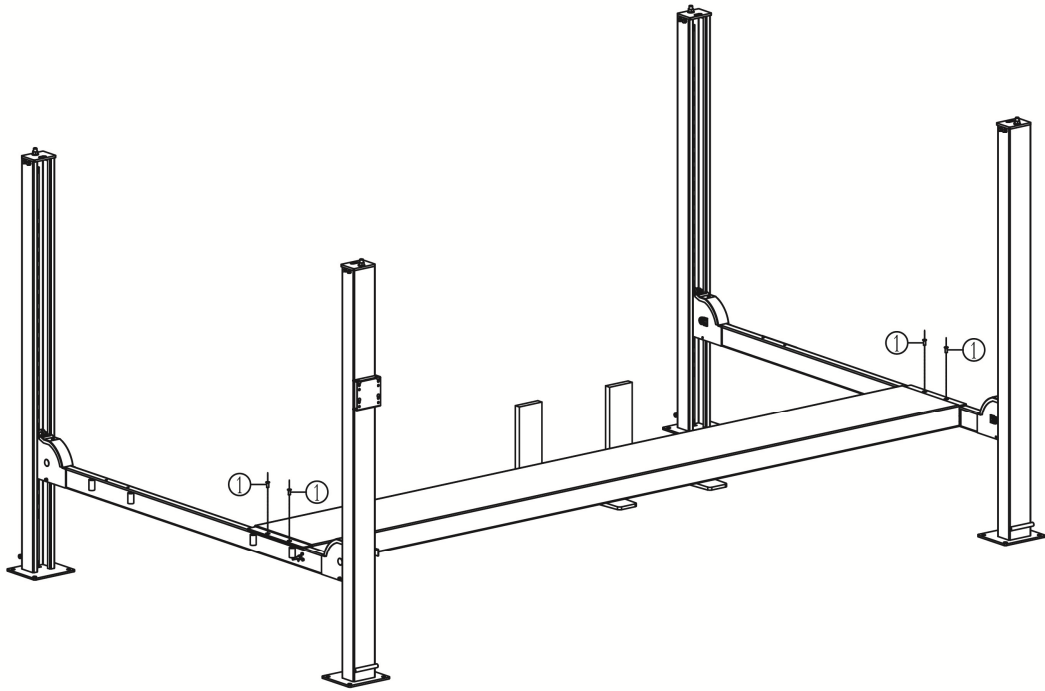

① Hex socket flat head screw M12*25

3. Fix the installation plate for drive-on ramps

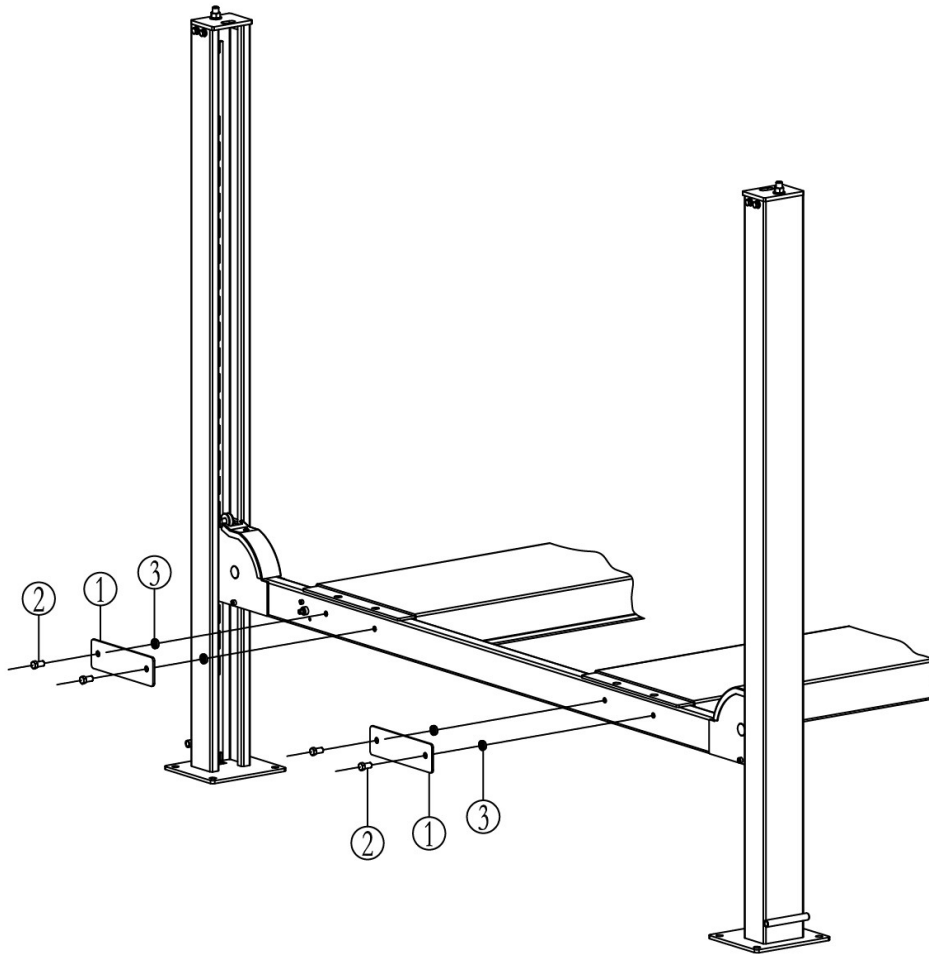

① Installation plate for drive-on ramp; ② M16*25 hex head screw; ③ Flat washer

Step 7: Fix transfer bar.

Insert the two section of the transfer bar respectively to the swing shaft assemblies in both crossbeams. Connect the two sections into a whole with screws.

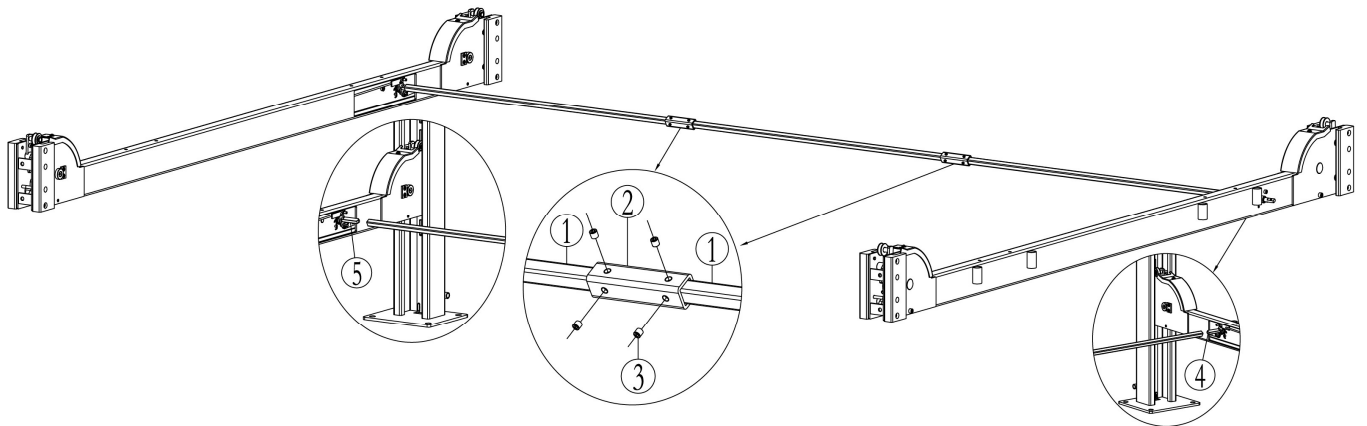

- ① Transfer bar; ② Connection tube; ③ M8*10 Hex socket flat head locking screw; ④ Main swing shaft; ⑤ Secondary swing shaft

Step 8: Fix steel cables and relevant accessories.

1. Route and fix steel cables;
2. Fix crossbeam protective covers;
3. Install release handle;

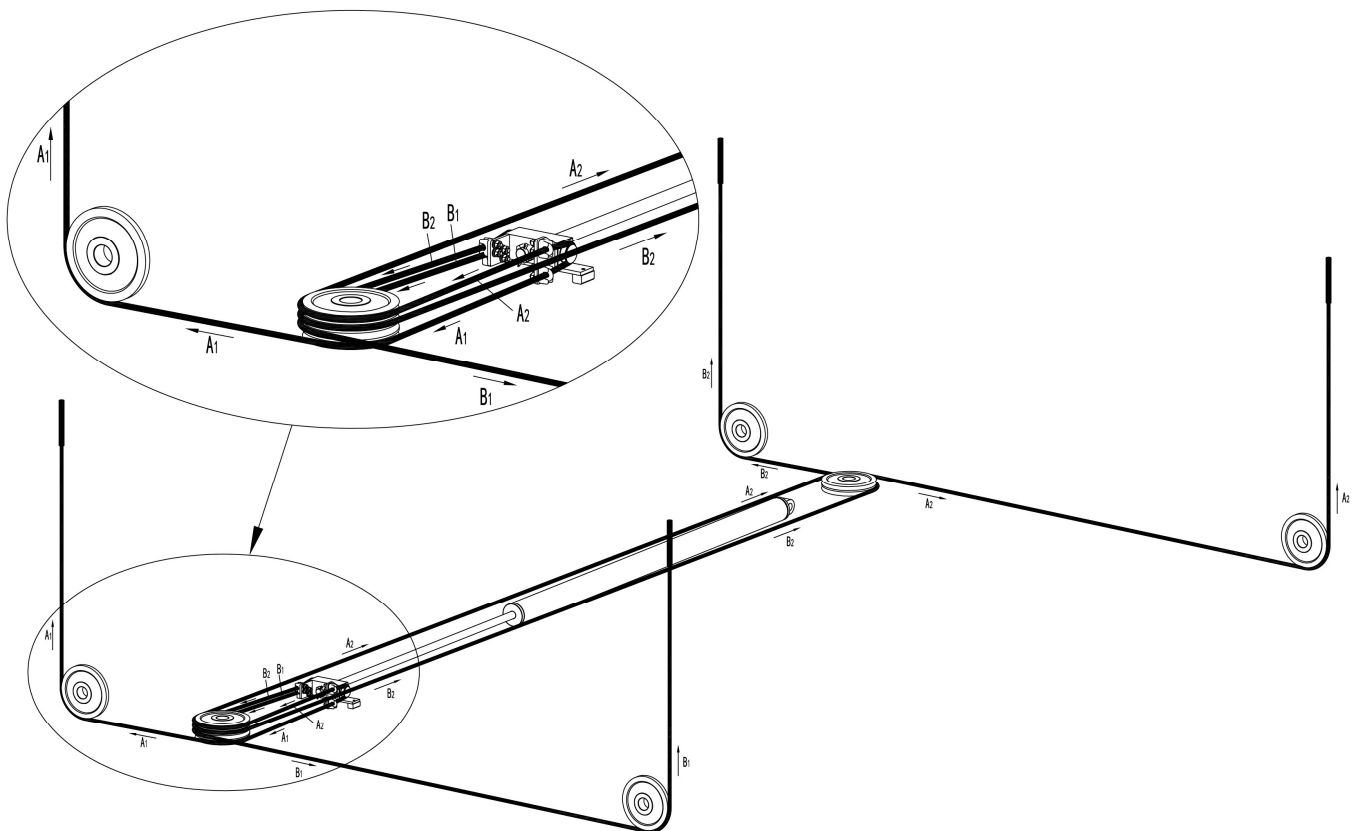

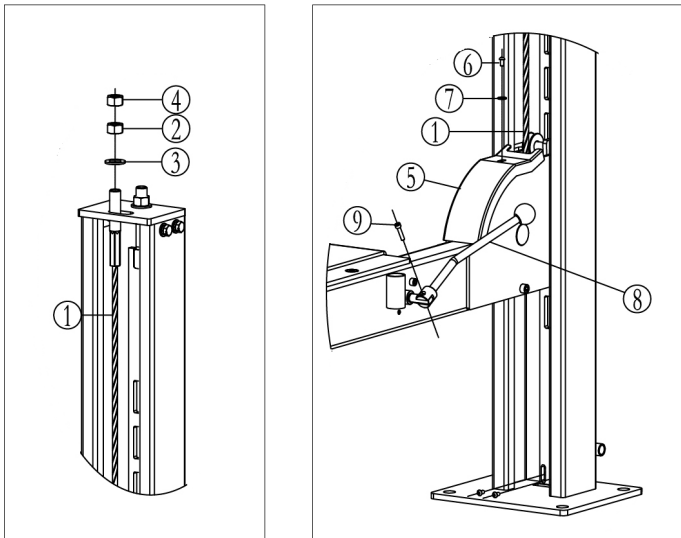

- ① steel cable; ② M20 hex nut; ③ φ20 flat washer; ④ M20 hex nut; ⑤ Protective cover; ⑥ M8*12 hex socket button head screw;
 ⑦ Ø8 flat washer; ⑧ Release handle; ⑨ M6*30 hex head screw

Step 9: Connect hydraulic hoses and electrical wires.

Refer to electrical and hydraulic connection diagrams before making connection.

Refer to Annex 1 when fix the hydraulic system.

Attention: Connect oil hoses as per the marks on the hoses and do not contaminate the hydraulic components during the connection.

It must be taken adequate care that all fittings are securely tightened. Severe leaking will occur if the hose fittings are not properly tightened.

Refer to Annex 2 when fix the electrical system.

Electrical connection must be done by qualified electricians.

Attention: For three phase power supply, if the lift doesn't raise and the motor may turn in the wrong direction, in such event, interchange wires U, V in the control cabinet.

Step 10: Fill with hydraulic oil

CLEAN AND FRESH OIL ONLY. DON'T FILL THE TANK COMPLETELY FULL.

Lift must be fully lowered before changing or adding hydraulic oil

Pour 12 liters (3.17 US gal) of hydraulic oil into the oil tank. The level of oil shall reach the tippet's volume mark of the tank.

Add more oil after running the lift for several cycles until the lift can rise to the maximum lifting height.

Note: It is recommended to use HM NO.46 hydraulic oil. Use HM NO.32 hydraulic oil when average temperature of the location is below 10 degree Celsius.

Change the oil 6 months after initial use and change once per year thereafter.

Step 11: Check the steel cable connection and check the function of mechanical locks.

1. Check the steel cable connection

Push the UP button until the steel cable is fully extended. Inspect steel cables at four corners of the two crossbeams to ensure that all cables are correctly in pulley slots and are not twisted with each other.

2. Check the function of mechanical locks.

Raise the platform above its first locking point. Push the down handle to see if the four corners of the platform are locked. If not being simultaneously locked, one side or one end of the platform could be slanted. Adjust screw ① which is indicated in the below drawing at the corresponding corner until the four locks can be engaged simultaneously.

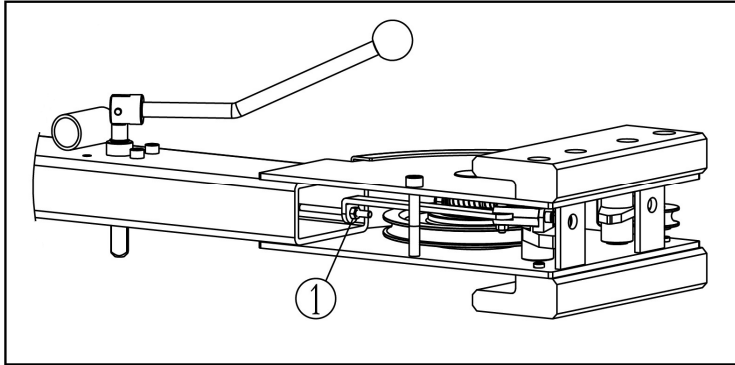

Push the UP button to release the mechanical locks. Push down the mechanical release handle and meanwhile push unloading handle to lower the platform to see if four mechanical locks can be released. If not adjust nut 1 at the corresponding corner.

Step 12: Level the platform

Attention: No vehicle on platforms when levelling.

1. Check and adjust the tension of steel cable.

Lower and raise the platform within 400mm (16") for several cycles. Raise the platform about 500mm (19-1/2") off the ground and measure the height at four corners of the platform. Adjust the nut that fix steel cable until the height measured at the four corners is almost the same.

2. Secondly, level the platforms after mechanical safety locks are engaged.

Raise the platform about 800mm (31") high and push the unloading handle to engage the mechanical safety lock. Judge if the mechanical locks could be engaged synchronously by listening to the sound. Engage the mechanical lock and measure the height at four corners of the platform. In case the height is different, adjust the nut (M20) that fix the safety ratchet and the top plate of the post until the height measured at the four corners is almost the same.

Step 13: Secure the post with anchoring bolts.

Specification of the bolts: M16*120

Screw torque: 80Nm.

Before anchoring, it is necessary to check again the position for each post properly by referring to the dimension scheme as well as the corresponding installation requirements.

- Drill holes using D18 carbide tipped masonry drill bit. Make sure to drill vertically down. Depth of the hole should be no less than 120mm.
- Clean the hole and check again the position of the posts to ensure they are correctly positioned.
- Use a spirit level to check the vertical alignment of the lifting posts. If necessary, place equalizing plates under the base plates.
- Impact and drive anchoring bolt into hole until nut and washer contact base.
- Tighten the nut with torque wrench to 80Nm.

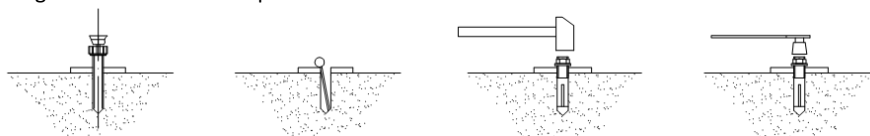

Step 14: Grease movable parts with NO.1 lithium base grease.

Grease steel ropes/ pulleys/ sliders.

4.4. Items to be checked after installation

S/N	Check items	YES	NO
1	Screw torque of expansion bolts : 80Nm (59 b.ft);	√	
2	Rising speed $\geq 20\text{mm/s}$ (3/4");	√	
3	Noise with rated load $\leq 75\text{dB(A)}$;	√	
4	Grounding resistance: not bigger than 4Ω ;	√	
5	Height difference of the two carriages $\leq 5\text{mm}$;	√	
6	Mechanical catch unit is robust and synchronized when running with rated load ;	√	
7	If the control button works as "hold to run"?	√	
8	If grounding wire is connected?	√	
9	If rising and lowering smoothly?	√	
10	If there is no abnormal notice during running with rated load?	√	
11	If there is no oil leakage when running with rated load?	√	
12	If there is no air leakage when running with rated load?	√	
13	If expansion bolts, nuts or circlips are well secured?	√	
14	If the max lifting height is 1970mm (77 9/16")?	√	
15	If Safety advices, name plate and logos are clear?	√	

OPERATION INSTRUCTIONS

5.1 Precautions

- ONLY authorized persons are permitted in the lift area.
- Do not try to raise the vehicle with excessive length or width. Otherwise there is risk of vehicle falling from lift.
- Inspect the space above and below the load and the loading carrying devices. It shall be free of obstructions before operating.
- Before raising operation, run the lift without load for a complete cycle to ensure it is in good condition.
- Before lifting the vehicle and during all operations on the vehicle, make sure that it is properly stopped by the hand brake.
- Check the vehicle after raising a short distance to ensure that it is correctly and safely positioned.
- It is forbidden for people to stand in the field of motion during raising or lowering movement.
- The load carrying device shall be observed by the operator throughout the motion of the lift.
- Engage the safety locking mechanism before entering under the raised vehicle.
- Avoid excessive rocking of vehicle while on the lift
- Do not climb onto the load or load carrying device when they are raised.

5.2 Operation instructions

The lift must be only used in a static position for lifting and lowering vehicles.

Only use this lift on a surface that is stable and capable of sustaining the load. Do not install the lift on any asphalt surface.

To avoid personal injury and/or property damage, permit only trained personnel to operate the lift. After reviewing these instructions, get familiar with lift controls by running the lift through a few cycles before loading vehicle on lifting platform.

Caution:

There must be sufficient space for parking. Pay close attention to the vehicle roof during ascending process so as to stop

vehicles colliding with the ceiling.

Before raising, make sure vehicle is neither front nor rear heavy and center of balance should be centered over the lift.

Before lowering, pay careful attention that all personnel and objects are kept clear.

RAISING

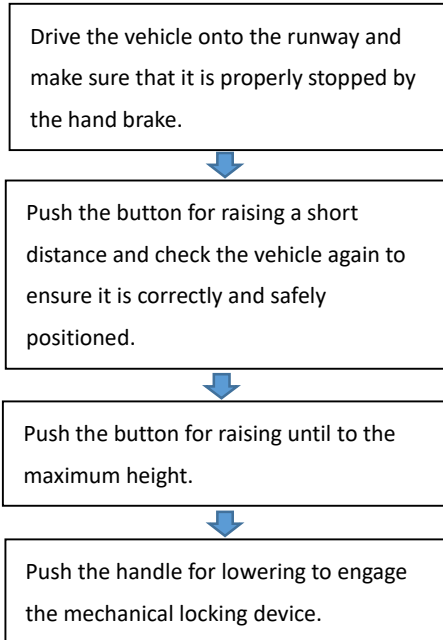

LOWERING

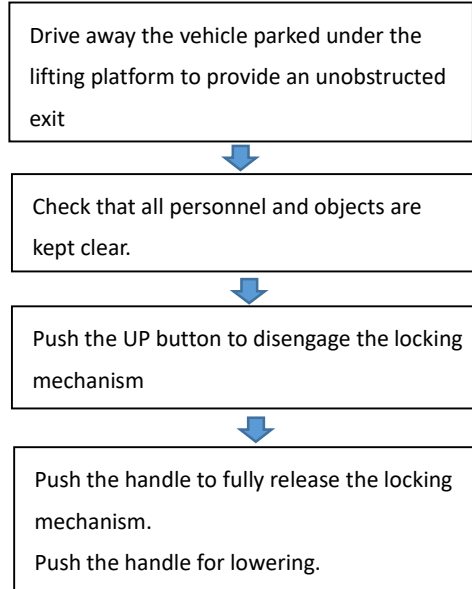

TROUBLE SHOOTING

ATTENTION: If the trouble could not be fixed by yourself, please do not hesitate to contact us for help .We will offer our solutions at the earliest time we can. The troubles could be judged and solved much faster more details or pictures of the trouble are provided.

TROUBLES	POSSIBLE CAUSES	SOLUTION
Abnormal noise	Abrasion exists on inside surface of the posts.	Grease the inside of the post.
	Trash in the post.	Clear the trash
Motor does not run and will not rise	Loose wire connection	Check and make a good connection.
	Blown motor.	Replace it.
Motor runs but will not rise	The motor run reversely.	Check the wire connection.
	Overflow valve is not well screwed up or jammed.	Clean or make adjustment
	Damaged gear pump.	Replace it.
	Too low oil level.	Add oil.
	The hose connection is loose.	Tighten it.
	The cushion valve is not well screwed up or jammed.	Clean or make adjustment
Platforms go down slowly after being raised	The oil hose leaks.	Check or replace it.
	Untightened oil cylinder.	Replace the seal.
	The single way valve leaks.	Clean or replace it.
	The overflow valve leaks.	Clean or replace it.
	Slack steel cable	Check and adjust the tightness.
Rising too slow	Jammed oil filter	Clean or replace it.

	Too low oil level.	Add oil.
	The overflow valve is not adjusted to the right position.	Make adjustment.
	Too hot hydraulic oil (above 45°) .	Change the oil.
	Abraded seal of the cylinder	Replace the seal.
	Inside surface of the posts is not well greased.	Add grease.
Lowering too slow	Jammed throttle valve	Clean or replace.
	Dirty hydraulic oil	Change the oil.
	Jammed anti-surge valve	Clean it.
	Jammed oil hose	Replace it.
The steel cable is abraded	No grease at installation or out of lifetime	Replace it.

MAINTENANCE

Easy and low cost routine maintenance can ensure the lift work normally and safely.

Following are requirements for routine maintenance.

Follow the below routine maintenance schedule with reference to the actual working condition and frequency of your lift.

Lubricated moving parts with NO.1 lithium grease before use.

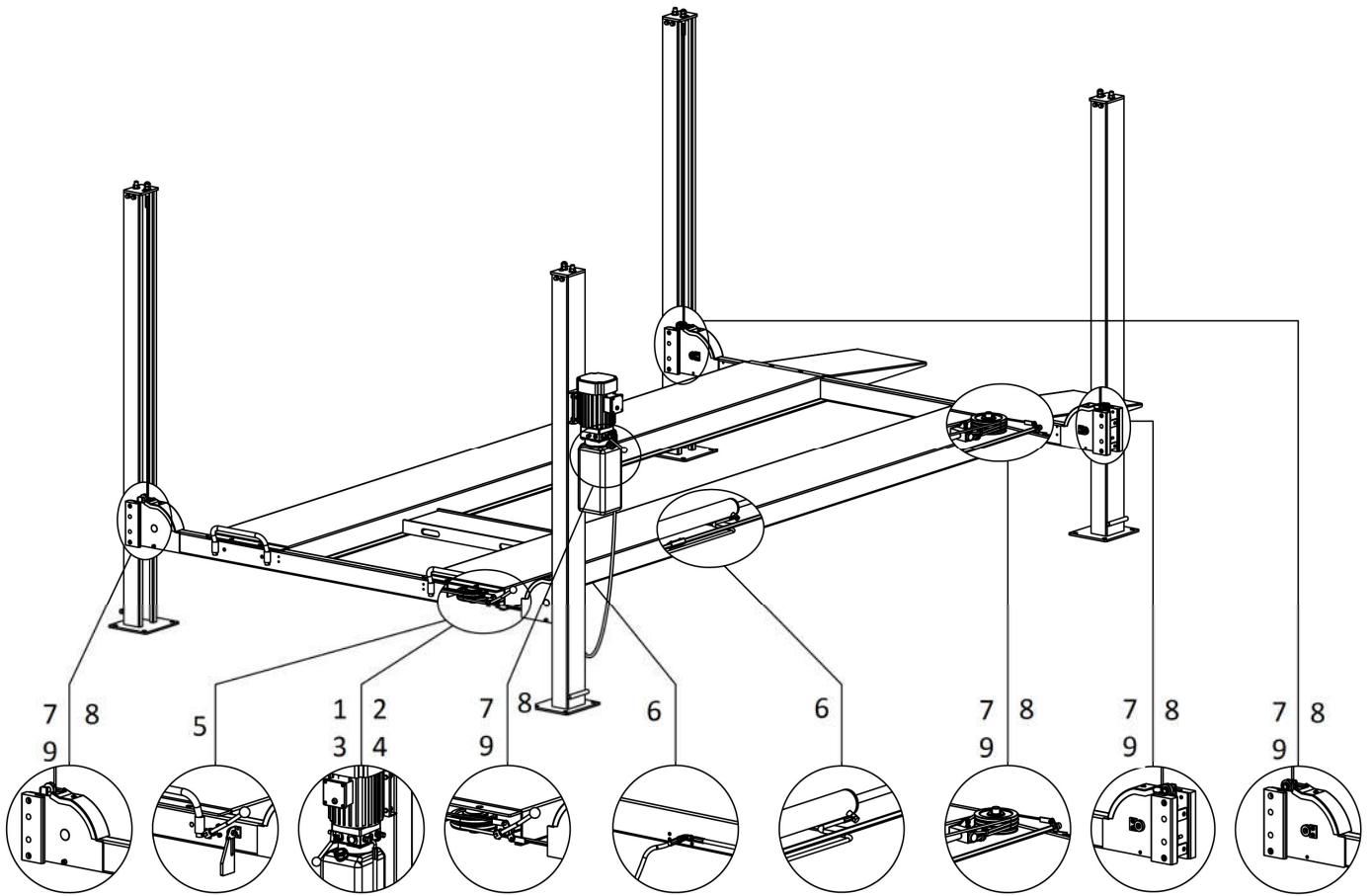

S/N	Components	Methods	Period
1	Control button	Check if control button work as "hold- to -run " and check if they work as the function indicated.	Every day
2	Descent handle	Check the function of the handle. Push down the handle for descending operation. Release the handle to stop descending movement.	Every day
3	Synchronization of the ascending movement	Push the UP button and listen to check if the sound comes from the mechanical locking unit in four post occurs almost at the same time. Inspect if both runways go upwards smoothly and synchronously. .	Every day
4	Synchronization of mechanical safety locking unit	Raise the runway more than 600mm and push the unloading handle to check if the mechanical locking unit at both sides of the crossbeam are engaged. Ensure the crossbeam are locked at the same height of the ratchet. Insect if front and rear side of the platform are at the same level.	Every day
5	Synchronization of the descending movement	Push release handle of safety locking unit and the descent handle. Watch and inspect if the runway descends smoothly.	Every day

S/N	Components	Methods	Period
6	Hydraulic block/Cylinder /Hose	Inspect and ensure no leakage before use.	Every week
7	Steel cable	Lubricated with NO.1 lithium grease. Check and ensure no broken wire, no deformation, no over-wearing and no rust before use. It is advised to change with new steel cables every 2 years or ten single wires have broken.	Every 3 months
8	Pulley	Lubricated with NO.1 lithium grease. Replace with new pulley in the case that: 1) Surface cracks 2) Uneven slot: bigger than 3mm 3) Over wearing :20% of pulley slot is abraded	Every 3 months
9	Pulley shaft	Add grease.	Every 3 months
10	Whole lift	Running the lift for several cycles with and without rated load. The lift can run steadily and smoothly with no abnormal noise.	Every 3 months
11	Hydraulic oil	Change the oil 6 months after initial use and once per year thereafter. Inspect the hydraulic oil and change the oil if the oil becomes black or there is dirt in the oil tank.	Every year

If users stick to the above maintenance requirements, the lift will always keep a good working condition and its service life could be extended.

Annex 1, Electrical schemes and parts list

(Note: For the specific requirements on voltage, the actual voltage of your lift may differ with the following diagram)

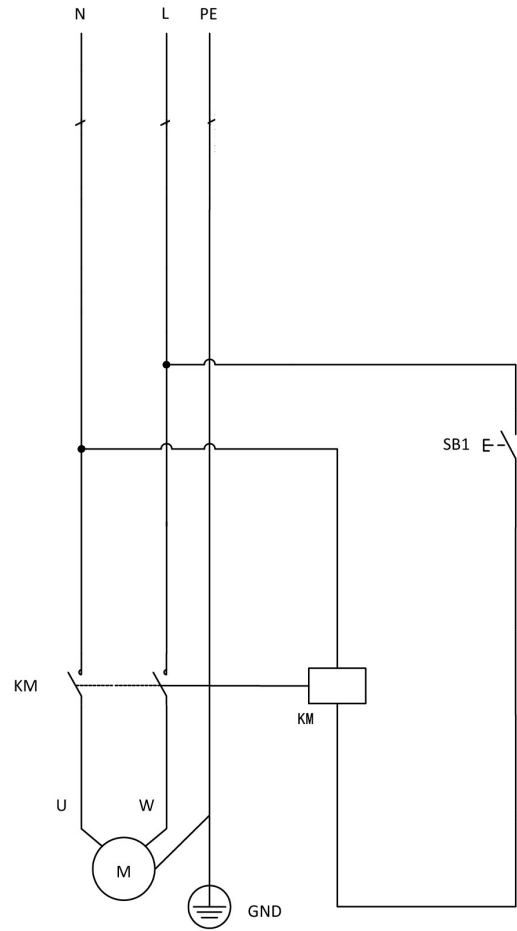
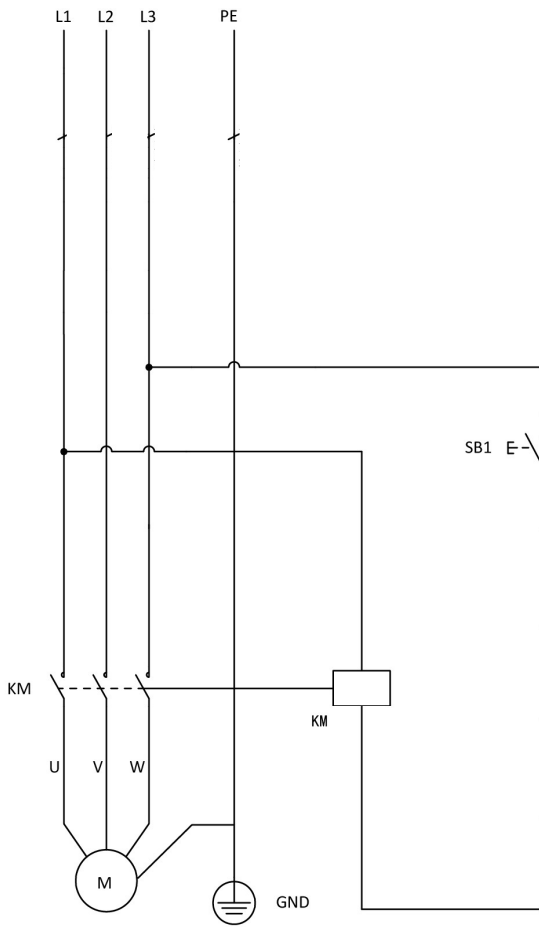

POS.	Code	Description	Qty
M		Motor	1
SB1	320401041	Button	1
KM	320901025	AC contactor (380V)	1
	320901003	AC contactor (220V)	1
	320901012	AC contactor (200V)	1
	320901014	AC contactor (110V)	1

NOTE: For power supply of other voltages, the motor and AC contactor is different.

Please check with our customers service people when order spare parts.

Annex 2, Hydraulic schemes and parts list

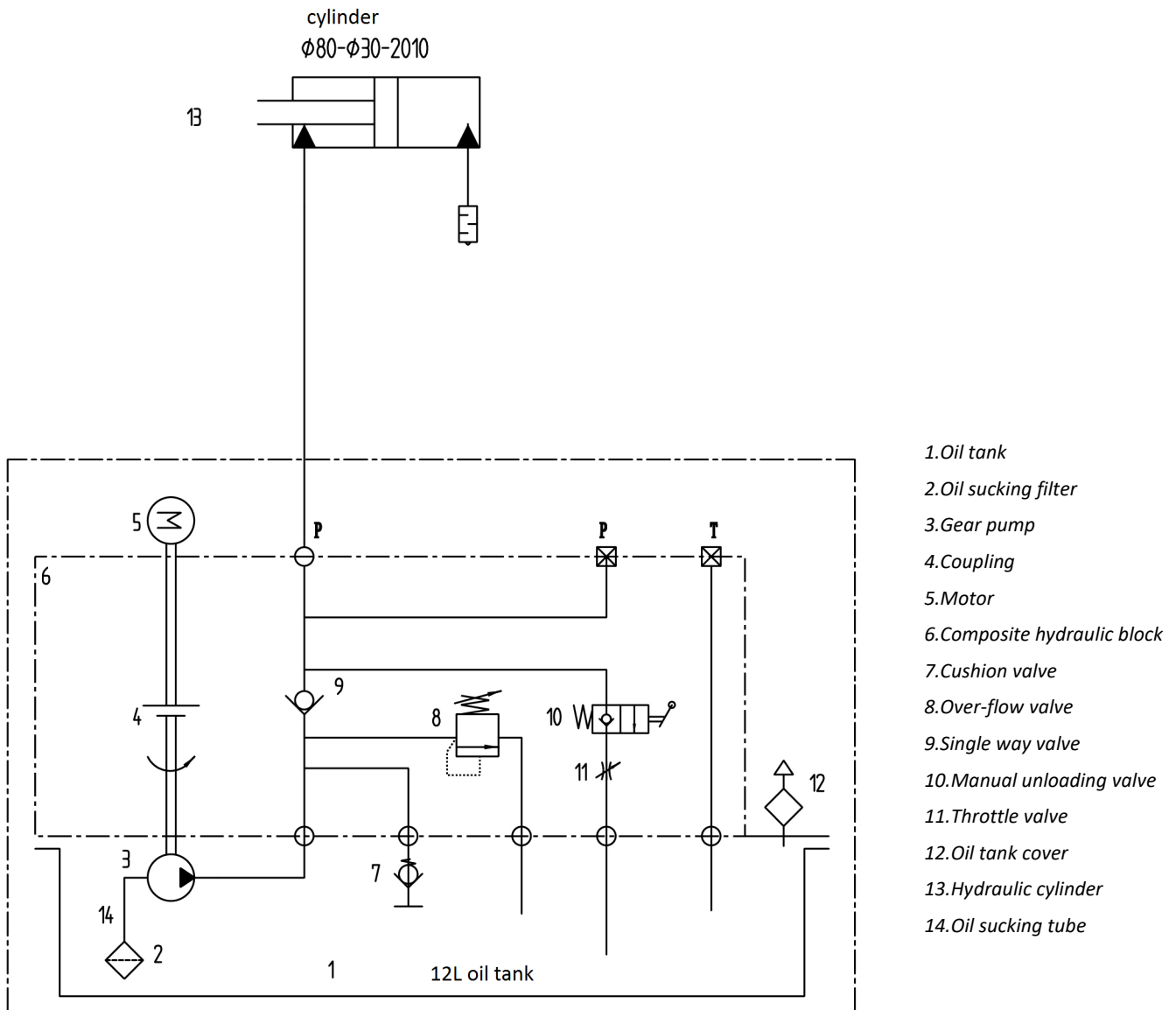

- 1.Oil tank
- 2.Oil sucking filter
- 3.Gear pump
- 4.Coupling
- 5.Motor
- 6.Composite hydraulic block
- 7.Cushion valve
- 8.Over-flow valve
- 9.Single way valve
- 10.Manual unloading valve
- 11.Throttle valve
- 12.Oil tank cover
- 13.Hydraulic cylinder
- 14.Oil sucking tube

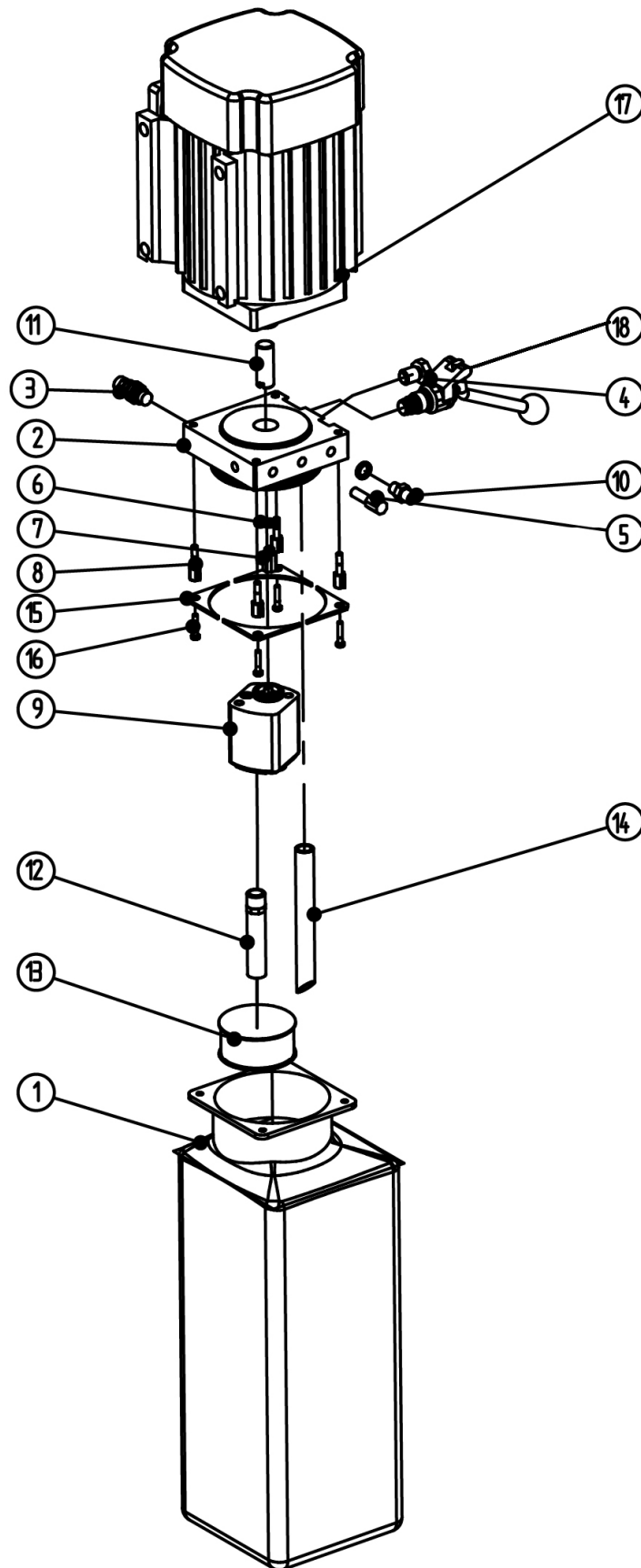

Installation, Operation and Parts Manual
HW-4P10S

POS.	Code	Description	Specification	Qty
1	330405030	Oil tank	12L	1
2	330101004	Composite hydraulic block	YF-2	1
3	330304001	Overflow valve	EYF-C	1
4	330302001	Single way valve	DYF-C	1
5	330305002	Throttle valve		1
6	207103019	Composite washer	M14	5
7	330301001	Cushion valve	HZYF-C1	1
8	202109064	Hex socket cylinder head screw	M6*30	4
9	330201006	Gear pump	CBK-F225/CBK-2.5F	1
10	310101003	Straight connector	M14*1.5,-G1/4	1
11	330404001	Coupling	YL-A	1
12	330401009	Oil sucking tube	XYGN-ZG-L350	1
13	330403002	Oil sucking filter	YG-B	1
14	330402001	Oil return tube	YH-D	1
15	410010091	Reinforced plate	6254E-A4-B12(6254A-A5-B12 50*50*4)	4
16	201103001	Hex flange screw	M5*25	4
17	320201082	Motor	110V-2.2KW -1PH-60H2-4P	1
18	330303001	Manual unloading valve	XYF-C	1

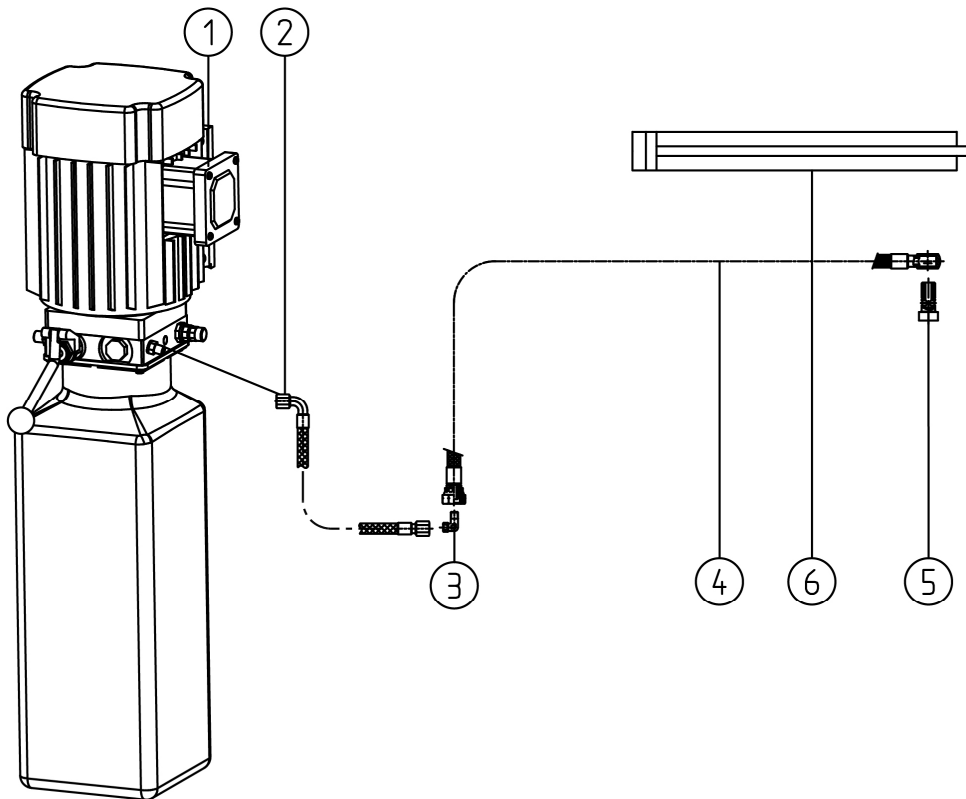

POS.	Code	Description	Specification	Qty
1		Power unit	2.2kW	1
2	624001903	Oil hose	L=2250	1
3	615022014	Right angle connector	612E-A8	1
4	624002037	Oil hose	L=2000	1
5	410281130	Cylinder connector	CJ-A12-B5-C10	1
6	615032066	Oil cylinder	YG3080-2010	1

Annex 3, Mechanical exploded drawings and parts list

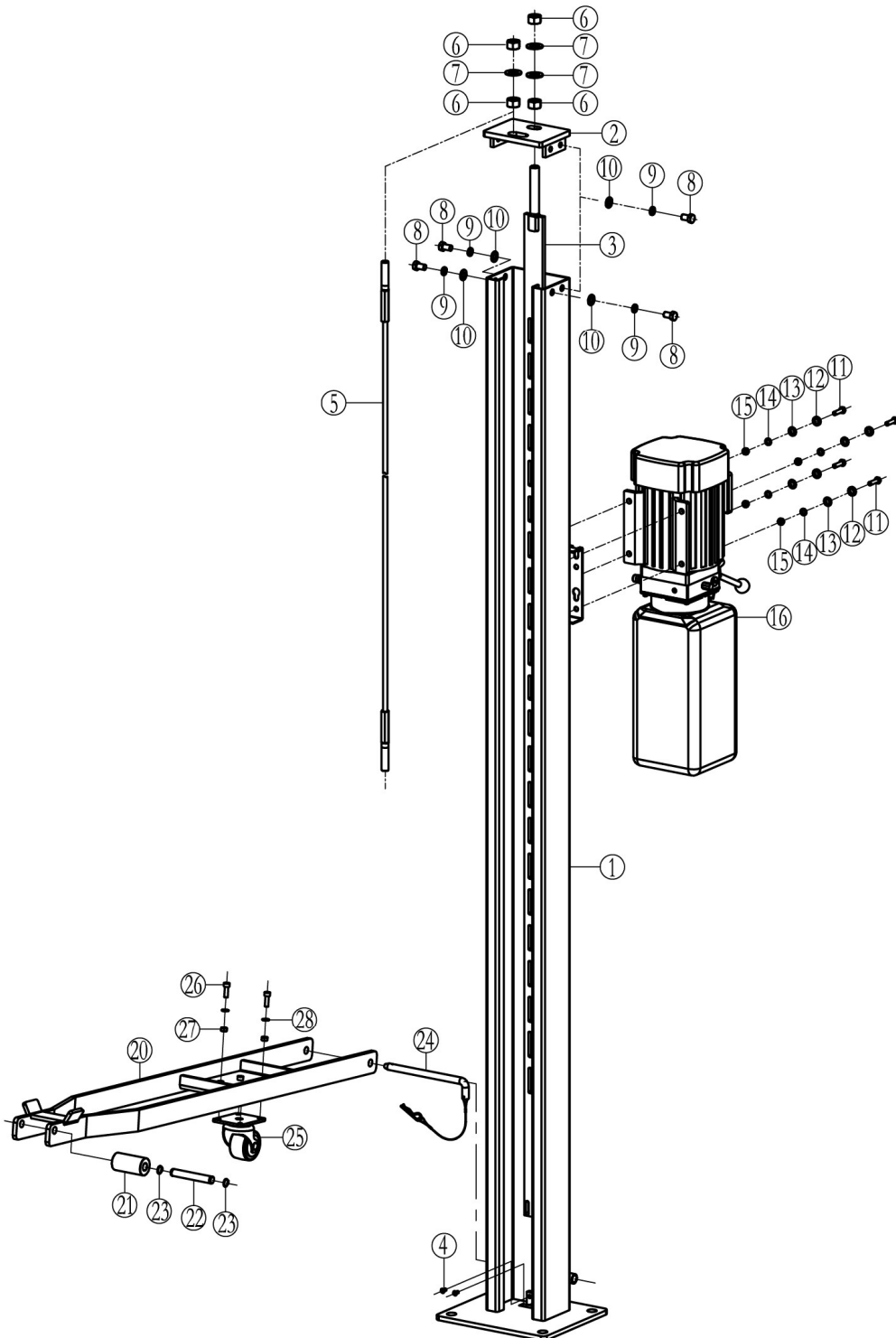

POS.	Code	Description	Specification	Qty
1	614032071	Power side post	4P10SP-A1-B1	1
1	614032072	Post	4P10SP-A1-B2	3
2	614032073	Top post plate	4P10SP-A1-B3	4

Installation, Operation and Parts Manual

HW-4P10S

POS.	Code	Description	Specification	Qty
3	612032074	Safety ratchet	4P10SP-A1-B4	4
4	202110005	Hex socket button head screw	M8*20	8
5	615032065	Steel cable	4P10SP-A3-B8	2
6	203101012	Hex nut	M20	8
7	204101011	Flat washer C	M20	4
8	201102026	Hex head full swivel screw	M12*25	16
9	204201006	Spring washer	M12	16
10	204101007	Flat washer C	M12	16
11	201102013	Hex head full swivel screw	M8*30	4
12	204201004	Spring washer	M8	4
13	420040010	Anti-shock pad	6254E-A23	4
14	204101005	Flat washer C	M8	4
15	203101005	Hex nut	M8	4
20	614032075	Portable kit	4P10SP-A1-B5	4
21	420320050	Plastic wheel	4P10SP-A1-B5-C5	4
22	410273461	Shaft III	410273461	4
23	204301005	Circlip	M16	8
24	615032044	Bolt	64P-A5	4
25	208107001	All directional wheel	81*59	4
26	202109030	Hex socket cylinder head screw	M8*25	16
27	203103006	Hex locking nut	M8	16
28	204101005	Flat washer C	M8	16

The portable kit(POS.20-28) is optional.

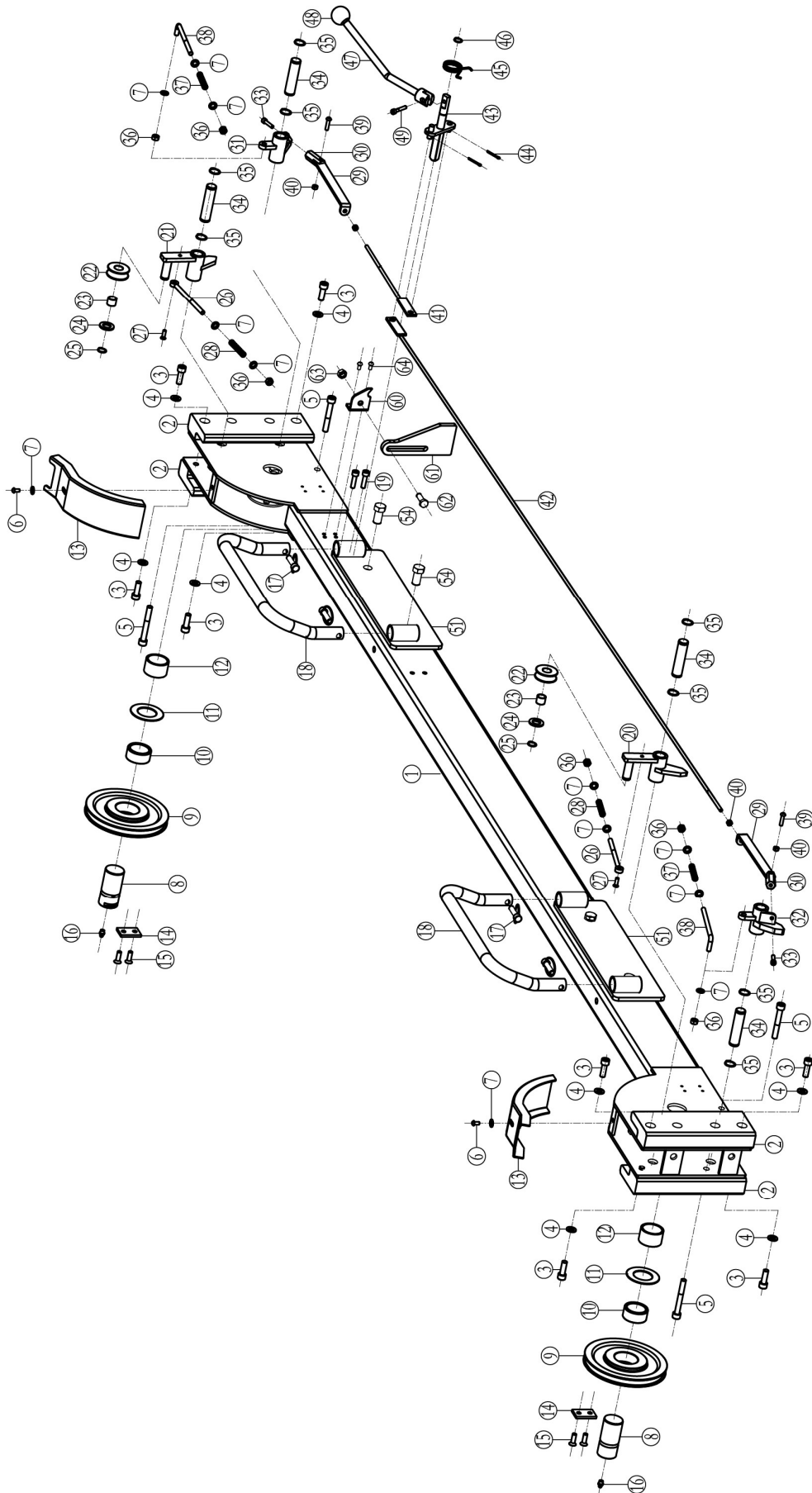

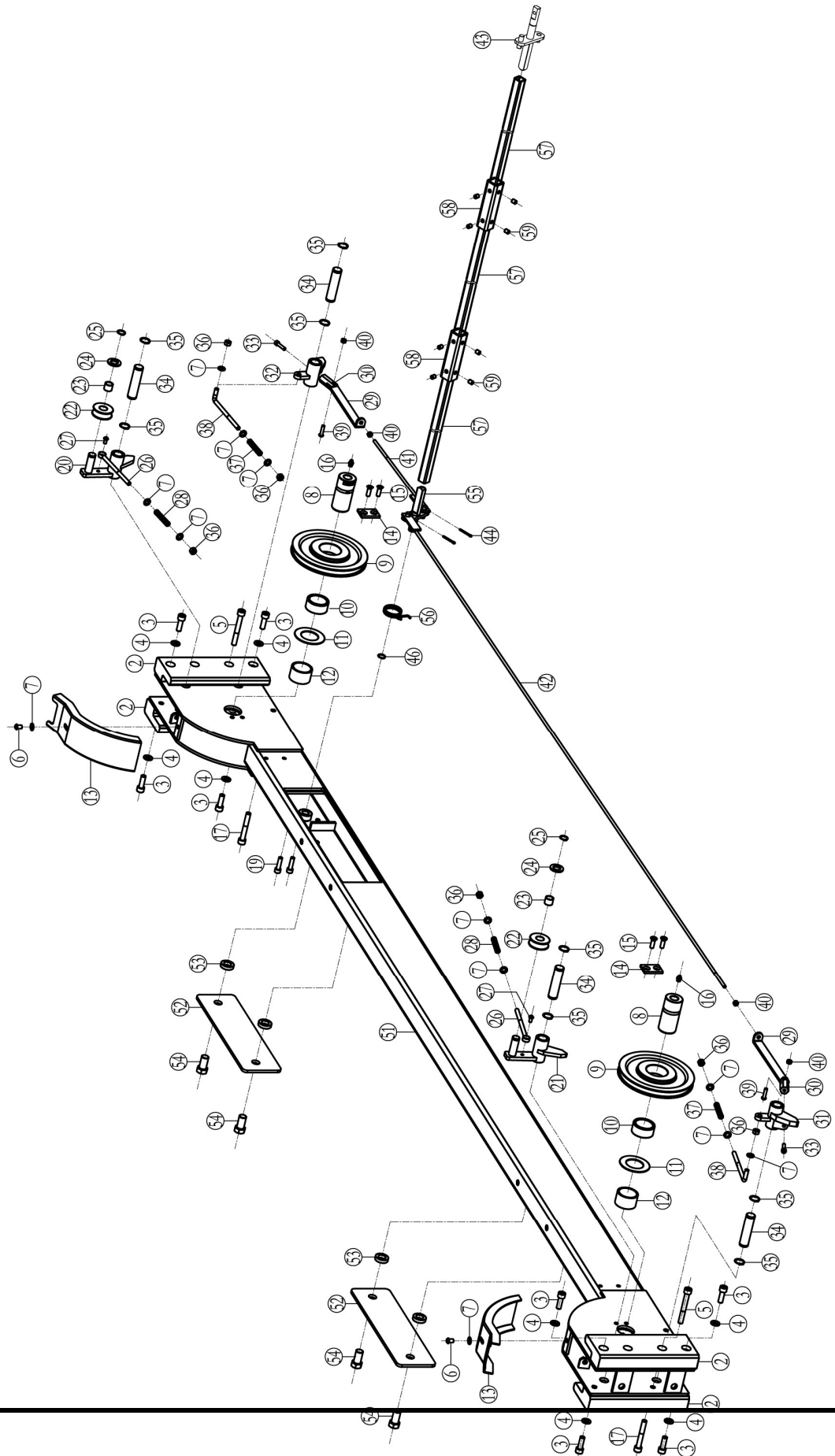

POS.	Code	Description	Specification	Qty
1	614032080	Power side crossbeam	4P10SP-A7-B1	1
2	420320060	Slider	4P10SP-A7-B17	8
3	202109044	Hex socket cylinder head screw	M10*35	16
4	204101006	Flat washer C	M10	16
5	202109075	Hex head full swivel screw	M10*80	8
6	202110004	Hex socket button head screw	M8*12	4
7	204101005	Flat washer C	M8	24
8	410322731	Pulley shaft A	4P10SP-A7-B13	4
9	410322721	Pulley A	4P10SP-A7-B12	4
10	205101069B	Bearing	6435B-A4-B13	4
11	410278751	φ40 large flat washer (42*75*2)	6435B-A4-B34	4
12	410322751	Space sheath	4P10SP-A7-B15	4
13	420320070	Protective cover	4P10SP-A7-B18	4
14	410270101B	Shaft retaining block	6435B-A3-B13	4
15	202110004	Hex socket button head screw	M8*12	8
16	208106001	Straight pressed oil cup	M8*1	4
17	206101100	Safety bolt	Φ10*45mm	4
18	410321501	Wheel retaining tube	64P-A7-B23	2
19	202109031	Hex socket cylinder head screw	M8*30	4
20	410322701	Safety block A1	4P10SP-A7-B10	2
21	410322711	Safety block A2	4P10SP-A7-B11	2
22	410270031B	Small pulley	6435B-A3-B5	4
23	205101001	Bearing	1615	4
24	204101009	Flat washer C	M16	8
25	204301005	Circlip	M16	4
26	612027003	Adjustable rod B	6435B-A3-B9	4
27	202103012	Cross socket cap head screw	M6*16	4
28	410270630	Spring	6435B-A3-B22	4
29	410322741	Adjustable chip B	4P10SP-A7-B14	4
30	410270601	Adjustable post	6435B-A3-B33	4
31	410321631	Safety block B1	64P-A7-B12	2
32	410321641	Safety block B2	64P-A7-B13	2
33	202109022	Hex socket cylinder head screw	M6*25	4
34	410321611	Safety shaft	64P-A7-B11	8

Installation, Operation and Parts Manual
HW-4P10S

POS.	Code	Description	Specification	Qty
35	204301007	Circlip	M20	16
36	203103006	Hex locking nut	M8	12
37	410300011	Spring washer	6435M-A3-B32	4
38	410321701	Adjustable rod A	64P-A7-B20	4
39	202110013	Hex socket button head screw	M6*25	4
40	203103005	Hex locking nut	M6	8
41	612032082	Release plate A	4P10SP-A7-B6	2
42	612032083	Release Plate B	4P10SP-A7-B7	2
43	612032042	Main swing rod	64P-A7-B3	1
44	206201001	Cotter pin	M2.5*30	4
45	410321691	Torsional spring	64P-A7-B19	1
46	204301004	Circlip	M15	2
47	612030003	Handle	6435M-A26	1
48	208105003B	Handle ball	BK	1
49	202109023	Hex socket cylinder head screw	M6*30	1
50	614032070	Holder for wheel retainer	4P10SP-A2-B3	1
51	614032081	The secondary crossbeam	4P10SP-A7-B2	1
52	410322593	Installation plate for drive-on ramp	4P10SP-A5-B14	2
53	410321681	Thicker washer	64P-A7-B17	4
54	201102040	Hex head full swivel screw	M16*30	8
55	612032043	Secondary swing assembly	64P-A7-B4	1
56	410321521	Torsional spring	64P-A7-B25	1
57	410322803	Transfer bar	4P10SP-A7-B23	3
58	410321493	Connection plate B for transfer bar	64P-A7-B22	2
59	202205006	Hex socket flat head locking screw	M8*10	8

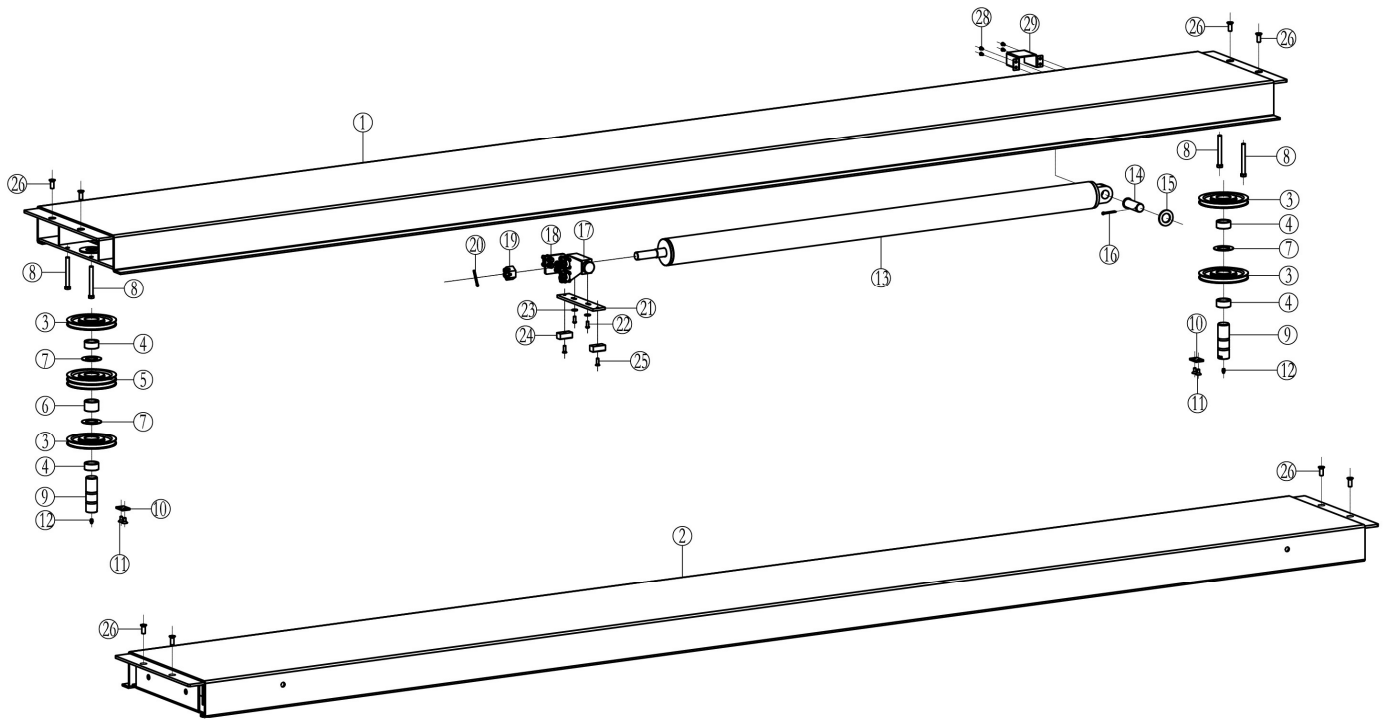

POS.	Code	Description	Specification	Qty
1	614032078	Main platform	4P10SP-A5-B1	1
2	614032079	Secondary platform	4P10SP-A5-B2	1
3	410322721	Pulley A	4P10SP-A7-B12	4
4	205101069B	Bearing	6435B-A4-B13	4
5	410322761	Double slots pulley	4P10SP-A7-B16	1
6	205101102	Bearing	40*50*34	1
7	410278751	φ40 large flat washer (42*75*2)	6435B-A4-B34	3
8	202109057	Hex socket cylinder head screw	M12*120	4
9	410270131	Pulley shaft B	6435B-A3-B18	2
10	410270101B	Shaft retaining block	6435B-A3-B13	2
11	202111005	Hex socket flat head screw	M8*15	4
12	208106001	Straight pressed oil cup	M8*1	2
13	615032066	Oil cylinder	YG3080-2010	1
14	410270281	Cylinder shaft II	6435B-A4-B26B	1
15	204101015	Flat washer	M30	1

Installation, Operation and Parts Manual

HW-4P10S

POS.	Code	Description	Specification	Qty
16	206201011	Cotter pin	M4*50	1
17	614032077	Connection block	4P10SP-A5-B3	1
18	208101001	Steel cable clip	10-6KTH L=57mm	4
19		Open slot nut	M27	1
20		Cotter pin	φ5*45	1
21	410290393	Guiding plate for oil cylinder	6435BWF-A4-B24	1
22	202110005	Hex socket button head screw	M8*20	4
23	204101005	Flat washer C	M8	4
24	420270240	Guiding slider	6435B-A4-B23	2
25	202111007	Hex socket flat head screw	M8*20	2
26	202111015	Hex socket flat head screw	M12*25	4
29	410322813	Protective cover	4P10SP-A7-B19	1
30	202110004	Hex socket button head screw	M8*12	20