

---

Forward this manual to all operators. Failure to operate this equipment as directed in this manual may cause injury.

## **HW-14AL OPERATION AND INSTALLATION MANUAL**



**Lifting Capacity: 14000lbs    Lifting Height: 1800mm**

**Single Phase/ 220V/60Hz 2.2 kW**

**Keep this operation manual near the machine at all times.  
Make sure that ALL USERS read and fully understand this manual**

### **SHIPPING DAMAGE CLAIMS**

When this equipment is shipped, title passes to the purchaser upon receipt from the carrier. Claims for the material damaged in shipment must be made by the purchaser against the transportation company at the time shipment is received.

### **BE SAFE**

Your new lift was designed and built with safety in mind. However, your overall safety can be increased by proper training and thoughtful operation on the part of the operator. **DO NOT** operate or repair this equipment without reading this manual and the important safety instructions shown inside.

---

# Hydraulic Four-column Vehicle Lift

**This instruction manual has been prepared especially for this kind lift operating.**

**This kind of lift is the product of many years of our continuous research; testing and development and is the most technically advanced lift on the market today.**

**READ and make sure fully understand THIS ENTIRE  
MANUAL BEFORE OPERATION.**

**RECORD HERE THE FOLLOWING INFORMATION  
WHICH IS LOCATED ON THE NAMEPLATE  
FOR OUR FOLLOW-UP SERVICE**

**Serial No.** \_\_\_\_\_

**Model No.** \_\_\_\_\_

**Manufacturing Date** \_\_\_\_\_

## WARRANTY

Your new lift is warranted for five years for equipment structure; one year for all operating components to the original purchaser, to be free of defects in material and workmanship.

The manufacturer shall repair or replace at their option for this period those parts returned to the factory freight prepaid which prove upon inspection to be defective.

This warranty does not extend to defects caused by ordinary wear, abuse, misuse, shipping damage, or lack of required maintenance.

This warranty is exclusive and in lieu of all other warranties expressed or implied. In no event shall the manufacturer be liable for special, consequential or incidental damages for the breach or delay in performance of the warranty. The manufacturer reserves the right to make design changes or add improvements to its product line without incurring any obligation to make such changes on product sold previously.

Warranty adjustments within the above stated policies are based on the model and serial number of the equipment. This data must be furnished with all warranty claims.

*Before installation, first check whether every element is in perfect condition.*

---

## INTRODUCTION

1. Carefully remove the crating and packing materials.  
CAUTION! Be careful when cutting steel banding materials as items may become loose and fall causing personal harm and injury.
2. Inspect the lift for any signs of concealed shipment damage or shortages. Remember to report any shipping damage to the carrier and make a notation on the delivery receipt.
3. Check the voltage, phase and proper ampere requirements for the motor shown on the motor plate. Wiring should be performed by a certified electrician only.

## CONSERVING THE MANUAL

The manual is an integral part of the lift, which it should always accompany even if the unit is sold. The manual must be kept in the vicinity of the lift in an easily accessible place so that the operator and maintenance staff must be able to locate and consult the manual quickly at any time.

**ATTENTIVE AND REPEATED READING OF CHAPTER 2, WHICH CONTAINS IMPORTANT INFORMATION AND SAFETY WARNINGS, IS PARTICULARLY RECOMMENDED.**

The lifting, transport, unpacking, assembling, installation, starting up, initial adjustment and testing, EXTRAORDINARY maintenance, repair, overhauls, transport and dismantling of the lift must be performed by specialist personnel.

The manufacturer declines all responsibility for injury to persons or damage to vehicles or objects when any of the above mentioned operations have been performed by unauthorized personnel or when the rack has been subject to abuse.

This manual indicates only the operative and safety aspects that may prove useful to the operator and maintenance works better understanding the structure and operation of the lift and for best use of the lift.

In order to understand the terminology used in this manual, the operator must have specific experience in workshop, service, maintenance and repair activities, the ability to interpret correctly the drawings and descriptions contained in the manual and be acquainted with the general and specific safety rules relevant to the country in which the machine has been installed.

The same applies to the maintenance fitter, who must also possess specific and specialized knowledge (mechanical, engineering) needed to perform the operations described in the manual in complete safety.

The words “operator” and “maintenance fitter” used in this manual are construed as follows:

**OPERATOR:** person authorized to use the lift.

**WORKING CONDITIONS:** 1、 Regarding ambient temperature shall be 5°C-40°C.

2、 Regarding humidity shall be 30-90%.

3、 Regarding transportation and storage temperature shall be between -10°C-50°C, and short period no exceeding 24 hours at up to 70°C.

4、 Regarding installation altitude max 1000m.

---

**MAINTENANCE FITTER:** person authorized for routine maintenance of the lift.

The end user can only use the machine in correct way as defined in instruction.

Loose clothes shall not be used protection cap shall also be used for long hair person, etc.

# Content

**INTRODUCTION..... 2**

**CONSERVING THE MANUAL..... 3**

**CHAPTER 1 TECHNICAL SPECIFICATIONS..... 5**

    1.1 ESSENTIAL PARAMETERS..... 5

    1.2 DIMENSIONS..... 5

**CHAPTER 2 SAFETY INSTRUCTIONS BEFORE INSTALLATION..... 6**

    2.1 GENERAL PRECAUTIONS..... 6

    2.2 RISKS OF ELECTRIC SHOCK:..... 7

    2.3 RISKS AND PROTECTION DEVICES..... 7

    2.4 IMPORTANT SAFETY INSTRUCTIONS..... 7

**CHARPTER 3 TOOLS REQUIRED..... 9**

**CHARPTER 4 INSTALLATION STEPS..... 9**

    4.1 STEP 1..... 9

    4.2 STEP 2..... 9

    4.3 STEP 3..... 10

    4.4 STEP 4..... 10

    4.5 STEP 5..... 10

    4.6 STEP 6..... 10

    4.7 STEP 7..... 10

    4.8 STEP 8..... 11

    4.9 STEP 9..... 11

**CHARPTER 5 WARNING OF OPERATING THE LIFT..... 13**

    5.1 TO RAISE LIFT..... 13

    5.2 TO LOWER LIFT..... 13

    5.3 REQUIRED MONTHLY UPKEEP..... 13

**CHARPTER 6 POSSIBLE FAILURE AND REMEDY..... 14**

    6.1 LIFT WILL NOT RAISE..... 14

    6.2 MOTOR WILL NOT RUN..... 15

    6.3 WIL NOT RAISE LOADED LIFT..... 16

6.4 LIFT WILL NOT STAY UP.....	17
6.5 LIFT LOWERS SLOWLY OR NOT AT ALL.....	18
6.6 EXTERNAL OIL LEAK.....	18
6.7 UNUSUAL NOISE.....	19

## CHAPTER 1 TECHNICAL SPECIFICATIONS

### 1.1 ESSENTIAL PARAMETERS

CAPACITY.....	14000lbs
Car max lifting height.....	1800mm
Runway length.....	5180mm
Runway Width.....	508mm
Width between post.....	3029mm
Drive Thru clearance.....	2700mm
Power.....	1ph,220v,60hz
Operating temperature.....	5°C-40°C
Work environment:.....	closed room
Relative humidity.....	≤90%
Sea level height.....	≤1000m

### 1.2 DIMENSIONS

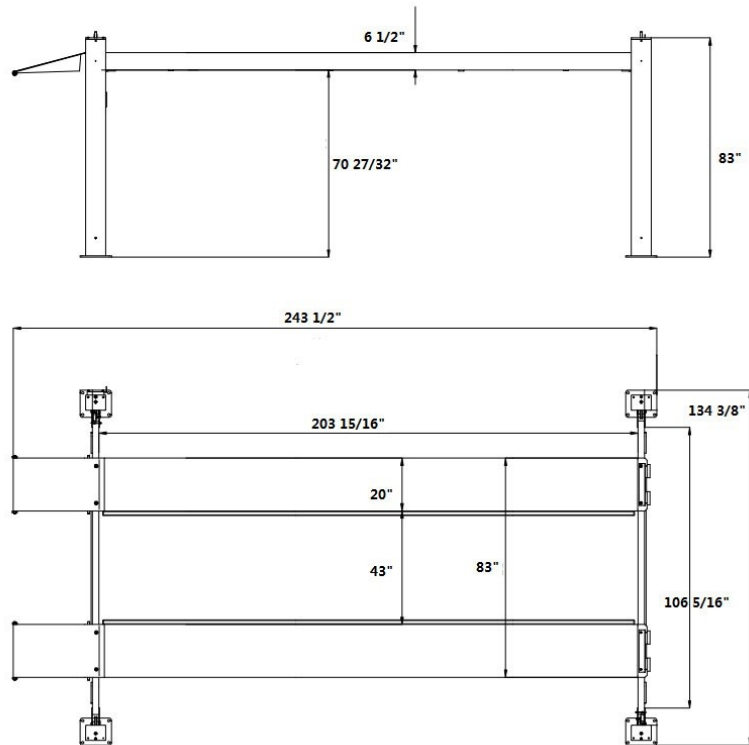

---

The underbody of cars with low ground clearance may interfere with the structure of the lift .Pay particular attention in the case of low body sports cars.

Always keep the capacity of the lift in mind in the case of vehicles with particular characteristics.

THE SAFETY area will be determined by the dimensions of the vehicle.

## **CHECK MAXIMUM LOAD CAPACITY AND LOAD DISTRIBUTION IN CASE OF LARGER VEHICLES. MAXIMUM WEIGHT OF THE VEHICLE TO BE LIFT**

It is vital to read this chapter of the manual carefully and from beginning to end as it contains important information regarding the risks that the operator and the maintenance fitter may be exposed to in the eventuality that the lift is used incorrectly.

The following text contains clear explanations regarding certain situations of risk or danger that may arise during the operation or maintenance of the lift, the safety devices installed and the correct use of such systems, residual risks and operative procedures to use (general and specific precautions to eliminate potential hazards).

### **WARNING**

Lift is designed and built to lift vehicles and hold them in the elevated position in a closed workshop. All other uses are unauthorized; in particular, the lift is not suitable for:

- Washing and respire work;
- Creating raised platforms or lifting personnel;
- Use as a makeshift press for crushing purpose;
- Use as goods lift
- Use as a jack for lifting vehicles or changing wheels.

*THE MANUFACTURE DISCLAIMS ALL LIABILITY FOR INJURY TO PERSONS OR DAMAGE TO VEHICLES AND OTHER PCABLERTY CAUSED BY THE INCORRECT AND UNAUTHORISED USE OF THE LIFT.*

**DO NOT USE THE LIFT WITHOUT PROTECTION DEVICES OR WITH THE PROTECTION DEVICES INHIBITED. FAILURE TO COMPLY WITH THESE REGULATIONS CAN CAUSE SERIOUS INJURY TO PERSONS, AND IRREPERABLE DAMAGE TO THE LIFT AND THE VEHICLE BEING LIFTED.**

## **CHAPTER 2 SAFETY INSTRUCTIONS BEFORE INSTALLATION**

### **2.1 GENERAL PRECAUTIONS**

The operator and the maintenance fitter are required to observe the prescriptions of accident prevention legislation in force in the country of installation of the lift.

---

Furthermore, the operator and the maintenance fitter must:

1. Always work in the scheduled working area as shown in the manual
2. Never remove deactivate the guards and mechanical, electrical, or other types of safety devices.
3. Read the safety notices affixed to the machine and the safety information in this manual.

In the manual all safety notices are shown as follows:

**DANGER:** indicates imminent danger that can result in serious injury or death.

**WARNING:** indicates situations and /or types of maneuvers that are unsafe and can cause injuries of various degrees or death.

**CAUTION:** indicates situations and /or types of maneuvers that are unsafe and can cause minor injury to persons and /or damage the lift, the vehicle or other psaltery.

## 2.2 RISKS OF ELECTRIC SHOCK:

Specific safety notice affixed to the lift in areas where the risk of electric shock is particularly high.

## 2.3 RISKS AND PROTECTION DEVICES

We shall now examine the risks to which the operator and the maintenance fitters may be exposed when the vehicle is immobilized in the raised position, together with the protection devices and adopted by the manufacture to reduce all such hazards to the minimum.

## 2.4 IMPORTANT SAFETY INSTRUCTIONS

*Read these safety instructions entirely and understand thoroughly before operating the equipment. Failure to operate this equipment as directed may cause injury.*

1. **READ AND UNDERSTAND** all safety warning procedures before operating lift.
2. **KEEP HANDS AND FEET CLEAR.** Remove hands and feet from any moving parts. Keep feet clear of lift when lowering. Avoid pinch points.
3. **KEEP WORK AREA CLEAN.** Cluttered work areas invite injuries.
4. **CONSIDER WORK AREA ENVIRONMENT.** Do not expose equipment to rain. DO NOT use in damp or wet locations. Keep area well lighted.
5. **ONLY TRAINED OR AUTHORIZED OPERATORS** should operate this lift. All non-trained personnel should be kept away from working area. Never let non-trained personnel come in contact with, or operate lift.
6. **USE LIFT CORRECTLY.** Use lift in the proper manner. Never use lifting adapters other than what is approved by the manufacturer.
7. **DO NOT** override self-closing lift controls.
8. **REMAIN CLEAR** of lift when rising or lowering vehicle.
9. **CLEAR AREA** if vehicle is falling.
10. **ALWAYS ENSURE** that the safety is engaged before any attempt is made to work on or near vehicle.
11. **DRESS PROPERLY.** Non-skid steel-toe footwear is recommended when operating lift.
12. **GUARD AGAINST ELECTRIC SHOCK.** This lift must be grounded while in use to protect the operator from electric shock. Never connect the green and yellow wire to a live terminal. This is for ground only.
13. **DANGER!** The power unit used on this lift contains high voltage. Disconnect power at the receptacle before performing any electrical repairs. Secure plug so that it cannot be accidentally plugged in during service.

**14. WARNING! RISK OF EXPLOSION.** This equipment has internal arcing or sparking parts which should not be exposed to flammable vapors. This machine should not be located in a recessed area or below floor level.

**15. MAINTAIN WITH CARE.** Keep lift clean for better and safe performance. Follow manual for proper lubrication and maintenance instructions. Keep control handles and/or buttons dry, clean and free from grease and oil.

**16. STAY ALERT.** Watch what you are doing. Use common sense. Be aware.

**17. CHECK FOR DAMAGED PARTS.** Check for alignment of moving parts, breakage of parts or any condition that may affect its operation. Do not use lift if any component is broken or damaged.

**18. NEVER** remove safety related components from the lift. Do not use lift if safety related components are damaged or missing.

**19. REGARDING AMBIENT TEMPERATURE,** shall be  $5^{\circ}\text{C} \sim 40^{\circ}\text{C}$ ; regarding humidity, shall be  $30 \sim 90\%$ ; regarding transportation and storage temperature, shall be between  $-10^{\circ}\text{C} \sim 50^{\circ}\text{C}$ , and short period no exceeding 24 hours at up to  $70^{\circ}\text{C}$ .

**20. THE REQUIRED INSTALLATION HEIGHT** above sea level is less than 1000m.

**21. SHOULD NOT EXCEED** the rated lifting capacity declared in the manual.

**22. RATED CAPACITY** of each lift arm is not greater than one fourth (1/4) of the overall lifting capacity.

**23. DANGER.** Travelling on lift is forbidden.

**24. IT IS NECESSARY** to refer to the complete operation instruction, especially for troubleshooting.

**25.** The field of motion of the load and of the lift shall be free of obstructions.

**26. IT SHALL DRAW ATTENTION** to the safe method of carrying the load and to the rule that, after raising a short distance, the vehicle shall be checked to ensure that it correctly and safely positioned.

**27.** The lift shall be observed by the operator throughout the whole lifting course.

**28. IT SHALL BE FORBIDDEN** for people to stand in the field of loading vehicle and of lifting parts during the lifting course.

**29. IT IS FORBIDDEN** to climb onto the loading vehicle and lifting parts when they are raised unless via a specially designed access.

**30. ABOUT HYDRAULIC OILS.** The first supplied oil shall be replaced after 1000 used times. Then it shall be replaced after 3000 times.

**31. LIFT ON & LIFT OFF.** Use forklift with loading capacity of 5T to load the lift. Note: Special lifting belt shall be used and steel rope or other rope should not as a matter of abrasion of the lift.

The lifting way shown as below:

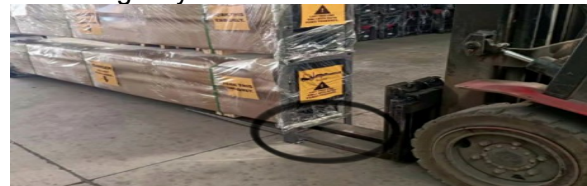

**32. STORAGE TEMPERATURE.** Regarding transportation and storage temperature, shall be between  $-10^{\circ}\text{C} \sim 50^{\circ}\text{C}$ , and short period no exceeding 24 hours at up to  $70^{\circ}\text{C}$ .



THIS SYMBOL POINTS OUT IMPORTANT SAFETY INSTRUCTIONS , WHICH , IF NOT FOLLOWED, COULD ENDANGER THE PERSONAL SAFETY AND/OR PROPERTY OF YOURSELF AND OTHERS AND MAY CAUSE PERSONAL INJURY OR DEATH. READ AND FOLLOW ALL INSTRUCTIONS IN THIS MANUAL BEFORE ATTEMPTING TO OPERATE THIS MACHINE.

## CHAPTER 3 TOOLS REQUIRED



- 
- Socket Wrench
  - Masonry Bit(3/4")
  - Hammer
  - Gradienter
  - Open-End Wrench Set(8mm ~ 25mm)
  - Monkey Wrench (350mm)
  - Percussion
  - Socket Head Wrench
  - Needle Nose Pliers
  - Tape Measure(5m)

## **IMPORTANT NOTICE**

Do not attempt to install this lift if you have never been trained on basic automotive lift installation procedures. Never attempt to lift components without proper lifting tools such as forklift or cranes. Stay clear of any moving parts that can fall and cause injury. These instructions must be followed to ensure proper installation and operation of your lift. Failure to comply with these instructions can result in serious bodily harm and void product warranty. Manufacturer will assume no liability for loss or damage of any kind, expressed or implied resulting from improper installation or use of this product.

**PLEASE READ ENTIRE MANUAL PRIOR TO INSTALLATION.**

### **CHAPTER 4 INSTALLATION STEPS**

#### **4.1 STEP 1**

( Selecting Site)

Before installing your new lift, check the following:

1. **LIFT LOCATION:** Always use architects plans when available. Check layout dimension against floor plan requirements making sure that adequate space is available.
2. **OVERHEAD OBSTRUCTIONS:** The area where the lift will be located should be away from overhead obstructions such as heaters, building supports, electrical lines etc.
3. **DEFECTIVE FLOOR:** Visually inspect the site where the lift is to install and check for cracked or defective concrete. All models **MUST** be installed on 2500 PSI concrete (tension  $\geq 200\text{kg/cm}^2$ , thickness  $\geq 300\text{mm}$ ) only conforming to the minimum requirements shown above. New concrete must be adequately dried by at least 28 days.

#### **4.3 STEP 3**

(Site Layout)

1. Determine which side will be the approach site.

#### **WARNING**

"DO NOT install this lift on any asphalt surface or any surface other than concrete.

"DO NOT install this lift on expansion seams or on cracked or defective concrete.

"DO NOT install this lift on a second / elevated floor without first consulting building architect.

"DO NOT install this lift outdoors unless special consideration has been made to protect the power unit from climate weather conditions.

#### **4.2 STEP 2**

( Floor Requirements )

This lift must be installed on a solid, even concrete floor with less than 3-degrees of slope, consider a survey of the site and/or the possibility of pouring a new level concrete slab.

2. Now determine which side you prefer the power unit to be located on. The **POWERSIDE** column has the power-unit mounting bracket attached to the side.

3. Once a location is determined, use a carpenter's chalk line to layout a grid for the post locations. Keep all dimensions and squareness within 1/8" or malfunctioning of the lift will occur.
4. After the post locations are properly marked, use a chalk or crayon to make an outline of the posts on the floor at each location using the post baseplates as a template.
5. Check all dimensions twice and make sure that the layout is perfectly correct.
6. Before continuing with the installation it is helpful to stand the posts up at their respective locations and get a visual of the shop, aisles and other clearances. Also, this is a good time to drive a vehicle into position and check for adequate clearance

#### **4.4 STEP 4**

##### **(Installing The POWERSIDE Column)**

1. Before proceeding, double check measurements and make certain that the bases of each column

#### **4.5 STEP 5**

##### **(Assembling and Installaton)**

- ①Put the Assembled overhead beam into the pole
- ②Install the sliding bush and the Column Head Plate.
- ③Fix the Head plate
- ④Fix the Fastening bolt of the sliding bush, but don't screw it down.
- ⑤Install the runway
- ⑥Put the cable through the Overhead Beam, and round the cable wheel, then through the Powerside column, and connect with the Cable Nip finally.
- ⑦Install the control unit and add adequate standard N46 anti-grinding hydraulic oil.
- ⑧Make sure Power and the air source for lock release (0.4-0.6Mpa) connected separately.

#### **4.6 STEP 6**

##### **(Gross Adjustment.)**

- ①Adjust the verticality and the orientation of the Powerside column, and fix it with Expansion Bolt.
- ②Adjust the location and the verticality of the other columns referring to the Location of the

are square and in line with the chalk line.

2. Using the baseplate on the POWERSIDE column as a guide, drill each anchor hole on the concrete approximately 6-1/2" deep using a Percussion Drill and 3/4" concrete drill-bit. To assure full holding power, do not ream the hole or allow the drill to wobble.
3. After drilling, remove dust thoroughly out of each hole using compressed air and/or wire brush. Make certain that the column remains aligned with the chalk line during this process.
4. Assemble the washers and nuts on the anchors. If shimming is required, insert the shims as necessary under the baseplate so that when the anchor bolts are tightened, the columns will be plumb.
5. With the shims and anchor bolts in place, tighten by securing the nut to the base then turning 2 -3 full turns clockwise. DO NOT use an impact wrench for this procedure.

Powerside column.

- ③Make sure the most Height error of every column is 3mm.

#### **4.7 STEP 7**

##### **(Experimental Operation)**

- ①Operate the Lift without load, and adjust the location, verticality and height of each columns.
- ②Adjust the length of the Articulate Bearing connecting with the unlocking cylinder
- ③Make sure the equipment operate swimmingly, locking and release work safely, and then fix all the columns with Expansion Bolts.

#### **4.8 STEP 8**

##### **(Precise Adjustment)**

- ①Rise the runway to the proper height where the operator work, and make sure it is locked.
- ②Put the Track Level Baron the runway, and adjust the height of the Sliding Bush in every column to make sure the max. Height Error of the runway in every direction is 3 mm.
- ③Screw the Fastening bolt of the Sliding Bush and make sure the Sliding Bush is fixed.

④ Lower the runway to the lowest Locking height. and adjust the Adjustment Nut of the Cable to make sure the Tension Degree of each Cable is coincident.

## 4.9 STEP 9 (Load Test)

- ① Inspect every parts of the equipment.
- ② Make sure the installation is correct.

### About the Power Unit

The standard power unit for your lift is 220 volt, 60HZ and single phase. All wirings must be performed by qualified electricians only. SEE WIRING INSTRUCTIONS ATTACHED ON MOTOR FOR PROPER WIRING INSTRUCTIONS.

### IMPORTANT INSTALLATION NOTES

- **DO NOT run power unit without oil. Damage to pump can occur.**
- **The power unit must be kept dry. Damage to power unit caused by water or other liquids such as detergents, acid etc., is not covered under warranty.**
- **Improper electrical hook-up can damage motor and will not be covered under**
- **Use a separate breaker for each power unit.**
- **Protect each circuit with time delay fuse or circuit breaker.**
- **Regarding 208~230V, single phase, use 15A fuse.**
- **Regarding 208~230V, three phase, use 15A fuse.**
- **Regarding 380~440V, three phase, use 10A fuse.**

③ Make sure there is adequate hydraulic oil in the control unit, and lubricating oil in every sliding and operating components.

Before putting it into use, you should make sure the lock system work swimmingly.

### NOTE!

- ① Only when the lift is on lock condition, should the repairing work be done.
- ② Make sure there is adequate oil in the Control Unit (Appropriate volume is 35mm-50mm to the Oil-adding hole)
- ③ The operators must be trained especially.

## WARNING

**RISK OF EXPLOSION!!** This equipment has internal arcing or sparking parts that should not be exposed to flammable vapors. Motor should not be located in a recessed area or below floor level.

### TRIAL RUNNING AND EXHAUSTING AIR

1. Connect circuit, fill up with lubricate, press down power unit button. The lift raises and cylinder begins to work. The lifting carriage might be creeping during its rising.
  2. Let the lift climb to the maximum height. DO NOT press the button if the lift rises to the maximum height, or it may result in power unit damage.
  3. Keep 5-6 seconds after the maximum height.
  4. Withdraw the release cable; press the lowering handle to lower the lift.
5. Repeat the following course.



## WARNING

During the whole lifting operation, observe all the operational units to check the correctness of operation. DO NOT lift vehicle when there is improperness.

## NOTE

1, Before drilling expansion bolt holes, complete the following steps to ensure that the column is properly installed. Ensure that the column installation size is shown in Figure below.

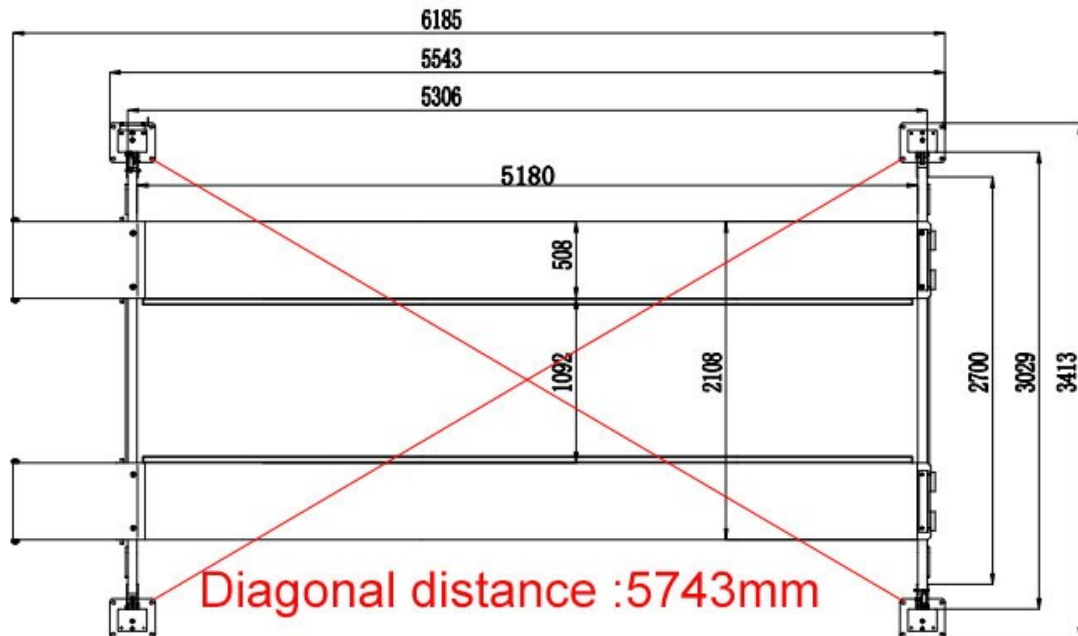

2, The fixing of the lifting bar and the wire rope is not final fixing. The final fixing is finished after the level adjustment.

3, The level adjustment of the wire rope shall be performed by qualified installers and done again after 50 and 300 uses of the lift.

4, When lifting vehicles, ensure that they are centrally located on both runways.

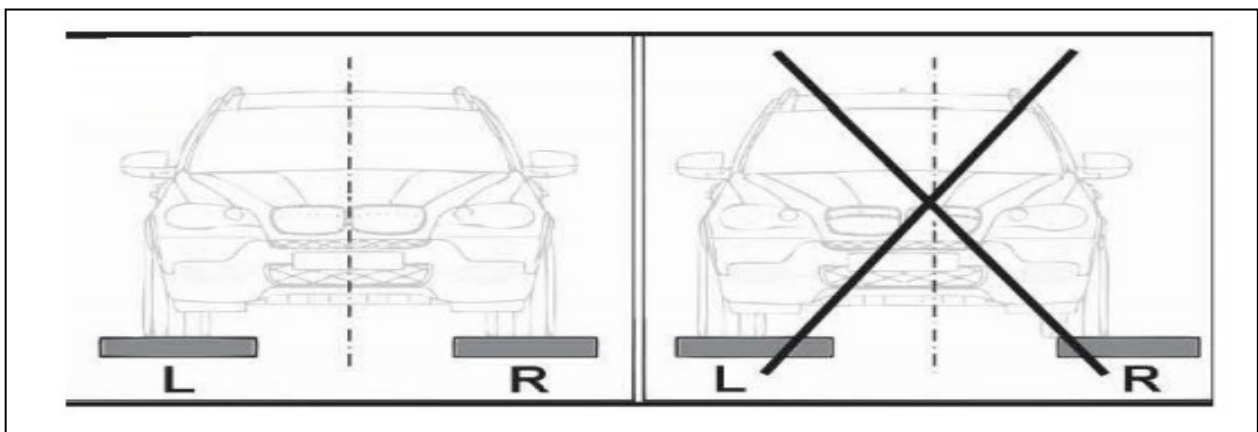

## CHAPTER 5 WARNING OF OPERATING THE LIFT



**WARNING**

---

### **5.1 TO RAISE LIFT**

- Read Installation and operating manuals (this manual) before using the lift.
- Always lift a vehicle according to the manufacturer's recommended lifting points..
- Adjust swing arms so that the vehicle is positioned with the center-of-gravity midway between pads.
- Raise lift by pressing down button until supports contact the bottom of the vehicle. Re-check to make sure that the vehicle is secure.
- After rising to the appropriate position, lock the lift.
- Make sure the safety lock is always available.

### **5.2 TO LOWER LIFT**

- First, raise the lift to the clear safeties.
- Raise safeties by pulling handles on each column.
- Make sure that tool trays, stands or persons are removed or evacuated from under vehicle.
- Lower vehicle by activating lowering handle.
- Before removing vehicle from lift area, position the lift arms and the supports to provide an unobstructed exit.

### **5.3 REQUIRED MONTHLY UPKEEP**

- Check all cable/cable connections, bolts and pins to ensure proper mounting.
- Visually inspect safeties for proper operation.
- Lubricate columns with grease.
- Inspect all anchor bolts and retighten if necessary.
- Check columns for squareness and erectness.
- Check the tensions of cables, adjust if necessary.
- If lift is equipped with overhead cut-off switch, check for proper operation.



## **WARNING**

1. If cement anchor bolts are loose, or any component of the lift is found to be defective, **DO NOT USE LIFT.**
2. Never operate the lift with any person or equipment below.
3. Never exceed rated capacity (14000lbs)
4. Always ensure that safeties are engaged before any attempt to work on or near the lift.
5. Never leave lift in an elevated position unless the safeties are engaged.
6. Do not permit electric motor to be damp! Motor damage caused by dampness is not covered under the warranty.

## CHAPTER 6 POSSIBLE FAILURE AND REMEDY

### 6.1 LIFT WILL NOT RAISE

#### LIFT WILL NOT RAISE

POSSIBLE CAUSE	REMEDY	INSTRUCTION
1 Air in oil (A, C, J & K)	A Check for proper oil level	The oil level should be up to the bleed screw in the reservoir with lift all the way down.
	B Remove check valve and inspect for contamination	Wash check valve in solvent and blow out with air. Re-install check valve.
2 Cylinder binding (M)	C Bleed cylinders	See installation manual.
	D Flush release to get rid of possible contamination	Hold release handle down and start unit allowing it to run for 15 seconds.
3 Cylinder leaks internally (M)	E Dirty oil	Replace oil with clean Dextron II ATF.
	G Tighten all fasteners	Tighten fasteners per engineering specification #2.11.01.
4 Motor runs backwards under pressure (B)	H Check for free movement of release handle	If handle does not move freely, replace bracket or handle assembly.
	I Check motor is wired correctly	Compare wiring of motor to electrical diagram on unit.
5 Lowering valve leaks (D, E, H, N & O)	J Check inlet tube length	Replace inlet hose assembly.
	K Oil seal damaged or cocked	Replace oil seal around pump shaft.
6 Motor runs backwards (I, & O)	L Relief valve hung up on cap	To remove relief valve and free up valve.
	M See installation manual	
7 Pump damaged (M, N, & O)	N Replace with new part	
	O Return unit for repair	
8 Pump won't prime (A, J, K, M, O & P)	P Check pump mounting bolts	Bolts should be 15 to 18 ft lbs.
9 Relief valve leaks (L, M, N, & O)		
10 Voltage to motor incorrect (I & M)		

## 6.2 MOTOR WILL NOT RUN

### MOTOR WILL NOT RUN

POSSIBLE CAUSE	REMEDY	INSTRUCTION
1 Fuse blown (E,B,A,C & D)	A Check for correct voltage	Compare supply voltage with voltage on motor nametag. Check that the wire is sized correctly. N.E.C. table 310 - 12 requires AWG 10 for 30A.
	2 Limit switch burned out (A,B,C & D)	
3 Microswitch burned out (A,B,C & D)	C Don't use extension cords	According to N.E.C. section 210-6 paragraph D: "The size of the conductors...should be such that the voltage drop would not exceed 3% to the farthest outlet for power...".
	4 Motor burned out (A,B,C,D & F)	
5 Voltage to motor incorrect (B & A)	E Reset circuit breaker / fuse	
	F Return unit for repair	
	G See installation manual	

### 6.3 WIL NOT RAISE LOADED LIFT

## WILL NOT RAISE LOADED LIFT

POSSIBLE CAUSE	REMEDY	INSTRUCTION
1 Air in oil (A, B, D & F)	A Check oil level	The oil level should be up to the bleed screw in the reservoir with the lift all the way down.
2 Cylinder binding (G)	B Check/tighten inlet tubes	Replace inlet hose assembly and suction cover.
3 Cylinder leaks internally (G)	D Oil seal damaged or cocked	Replace oil seal and install according to sheet #8.3.2.
	E Remove check valve and inspect for contamination	Wash check valve in solvent and blow out with air. Re-install check valve.
4 Lift overloaded (G & H)	F Bleed cylinders	Refer to installation manual.
	G See installation manual	
	H Check vehicle weight	Compare weight of vehicle to weight limit of the lift.
5 Lowering valve leaks (I, J, K, A & G)	I Flush valve	Hold release handle down and start unit allowing it to run for 15 seconds.
	J Replace with new part	
6 Motor runs backwards (E, K & L)	K Return unit for repair	
	L Check motor is wired correctly	Compare wiring of motor to electrical diagram on unit drawing.
7 Pump damaged (G, J & K)	M Relief valve hung up	Remove cap and free up, blow out with air.
8 Pump won't prime (A, B, D, F, G & K)		
9 Relief pressure incorrect (G, J & K)		
10 Relief valve leaks (M, J, K & G)		
11 Voltage to motor incorrect (L & G)		



## 6.4 LIFT WILL NOT STAY UP

### LIFT WILL NOT STAY UP

POSSIBLE CAUSE	REMEDY	INSTRUCTION
1 Air in oil (A, D & F)	A Check oil level	The oil level should be up to the bleed screw in the reservoir with the lift all the way down.
	D Oil seal damaged or cocked	Replace oil seal around pump shaft.
2 Check valve leaks (E, H, I & J)	E Remove check valve and inspect for contamination	Wash check valve in solvent and blow out with air. Re-install check valve.
	F Bleed cylinders	Refer to installation manual.
3 Cylinder leaks Internally (J)	G Flush valve	Hold release handle down and start unit allowing it to run for 15 seconds.
	H Replace with new part	
4 Lowering valve leaks (G, H, I, A & J)	I Return unit for repair	
	J See installation manual	
5 Leaking fittings (K)	K Check complete hydraulic system for leaks	

## 6.5 LIFT LOWERS SLOWLY OR NOT AT ALL

### LIFT LOWERS SLOWLY OR NOT AT ALL

POSSIBLE CAUSE	REMEDY	INSTRUCTION
1 Cylinder binding (A)	A See installation manual	
	B Replace with new part	
2 Release valve screen clogged (E, B, D & C)	C Return unit for repair	
	D Use clean Dextron II ATF only	If ATF is contaminated, replace with clean ATF.
	E Clean release valve screen	Wash release valve in solvent and blow out with air.

## 6.6 EXTERNAL OIL LEAK

### EXTERNAL OIL LEAK

1 Breather element full of oil (A.B.C&D)	A Check for proper oil level	The oil level should be up to the bleed screw in the reservoir with lift all the way down
	B Replace with new part	
	C See installation manual	
2 Allen plugs loose (E)	D Use clean Dextron II ATF only	
	E Tighten all plugs	Tighten plugs per engineering specification #2.11.01.
	F Return unit for repair	
3 Loose tank (K)	G Tighten all hydraulic fittings	
	H Check/tighten inlet tube and cover	Replace inlet hose assembly and/or suction cover.
4 Oil comes out breather (A.D.B.C & F)	I Oil seal leaks	Replace oil seal around pump shaft.
	J Bleed cylinder	Refer to installation manual.
	K Tighten tank mounting bolts	Tighten per engineering specification#2.11.01.
5 Oil comes out tank mounting (E)		
6 Hoses/fittings loose (C.G)		
7 Air in oil (H.I.J)		

### 6.7 UNUSUAL NOISE

## UNUSUAL NOISE

1 Air in oil (A.B.D&F)	level	screw in the reservoir with lift all the way down.
2 Lift overloaded (G & H)	B Check/tighten inlet tubes	Replace inlet hose assembly and suction cover.
3 Motor burned out (K.I.M.I & J)	D Oil seal damaged or cocked	Replace oil seal around pump shaft

4 Motor mounting bolts loose (N)	E Remove check valve and inspect for contamination	Wash check valve in solvent and blow out with air. Re-install check valve.
	F Bleed cylinders	Refer to installation manual.
5 Motor runs backwards (L.E& J)	G Check vehicle weight	Compare weight of vehicle to weight limit on the lift.
	H See installation manual	
6 Pump damaged (H.I & J)	I Replace with new part	
	J Return unit for repair	
	K Check for correct voltage	Compare supply voltage with voltage on motor instruction. Check that the wire is sized correctly. N.E.C. table 310-12 requires Awe 10 for 30A.
7 Pump won't prime (A.B.D.E.H.I& P)	L Check motor is wired correct	Compare wiring of motor to electrical diagram on unit drawing.
8 Relief valve leaks (H.I.J & O)	M Don't use extension cords	According to N.E.C. section 210-6
9 Voltage to motor incorrect (I.& H)	N Tighten all fasteners	Tighten fasteners per engineering specification#2.11.01.
	O Relief valve hung up	Remove relief valve and blow relief out with air.
	P Pump bolts loose	Tighten fasteners per engineering specification#2.11.01.