

NEW

FLIR LADYBUG[®] 5+

USB 3.1 Gen 1

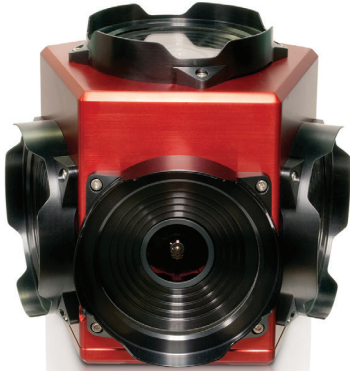

30 MP, 360° SPHERICAL CAMERA IMAGING SYSTEM

The Ladybug 5+ adopts a new Sony Pregius global shutter CMOS sensor for superior image quality, without solar smearing in outdoor images and delivering excellent color response, low noise and high dynamic range (approx. 70.6dB dynamic range or 12 stops) indoors and out.

The Ladybug5+ is capable of capturing 30MP of image data at 30fps, or 15MP at 60fps. Fast f/2.5 lenses enable excellent low-light image quality with an average pixel spatial resolution of 2mm @ 10m. An optional pulse-per-second clock sync and reference time synchronization via GNSS NMEA sentences enables accurate time stamps and tight integration with external devices.

The Ladybug5+ is designed from the ground up to be robust and reliable. Operating temperatures range from -20 to 50°C, while lens covers seals, rain exit ports and voltage spike protection all combine to provide flexibility and reliability in real-world conditions.

Specifications

Model	Version	MP	Imaging Sensor
LD5P-U3-51SSC-R	Red	30 MP (5 MP x 6 sensors)	<ul style="list-style-type: none"> ■ Sony IMX264, 2/3", 3.45 μm ■ Global shutter ■ 30 FPS (JPEG Compressed) at 2448 x 2048 ■ 60 FPS (JPEG Compressed) at 2448 x 1024
LD5P-U3-51SSC-B	Black		

A/D Converter	12-bit
Data Formats	Raw8, Raw12, Raw16 uncompressed, and JPEG compressed
Precision Timestamps	RS232 GPS NMEA string and PPS over GPIO
Image Processing	Shutter, gain, white balance, gamma and JPEG compression, are programmable via software
Shutter	Global shutter; Automatic/manual/one-push/extended shutter modes (0.02 ms to 2 seconds (extended shutter))
Pixel Spatial Accuracy	Average accuracy of 2 mm at 10 m
Gain	Automatic/manual/one-push modes for 8-bit formats; manual mode for 12-bit formats (0-18 dB)
Gamma	0.50 to 4.00
White Balance	Presets/automatic/manual
High Dynamic Range	Cycle 4 gain and exposure presets
Digital Interface	USB3 with locking screws for secure connection
Transfer Rates	5 Gbit/s
GPIO	12-pin GPIO connector for external trigger input, strobe output, and camera power
External Trigger Modes	Standard, skip frames, overlapped, and multi shot trigger modes
Memory Channels	2 memory channels for custom camera settings
Flash Memory	1 MB
Case	Machined aluminum housing, anodized red or black; single unit, water resistant
Dimensions	197 mm diameter, 160 mm height (with lens hoods)
Mass	3.0 kg
Power Consumption	12-24 V, 13 W via GPIO (external power required)
Machine Vision Standard	IIDC v1.32
Camera Control	via Ladybug SDK, CSRs, or third party software
Camera Updates	In-field firmware updates
Optics	6 high quality 4.4 mm focal length lenses
Field of View	90% of full sphere
Spherical Distance	Calibrated from 2 m to infinity
Focus Distance	~200 cm. Objects have an acceptable sharpness from ~60 cm to infinity
Environmental Sensors	Temperature, humidity
Temperature	Operating: -20° to 50°C; Storage: -30° to 60°C
Humidity	Operating: 20 to 80% (no condensation); Storage: 20 to 95% (no condensation)
Compliance	CE, FCC, RoHS
Operating System	Windows 7, Windows 8, or Windows 10, 64-bit; Linux for capture only; with 8 GB RAM
Environmental Rating	IP65 Certified
Warranty	2 Years

KEY FEATURES

Superior Image Quality

Sony Pregius[®] global shutter CMOS sensors provide superb image quality across a wide range of lighting conditions without smear or blooming.

Enhanced Image Quality with Post Processing

The workflow starts with Ladybug5+ capturing, compressing, and transmitting full bit depth 12-bit images. Users then use LadybugCapPro to apply white balance, gamma, and other image processing functions for maximum image quality.

Flexibility with Non Destructive Post-Processing

The capture and post workflow model allows users to maintain flexibility by being able to return to the original content and re-apply post processing steps as desired.

High Bandwidth Interface

USB 3.1 Gen 1 interface makes 12-bit RAW imaging possible.



Hardware Development Kit

LADYBUG[®] SDK

Complete Spherical Image Acquisition and Processing Software

SDK FEATURES

- GUI applications (LadybugCapPro) for full access to camera and processing functionality
- Windows / Linux collect-only command line application (source code included) enables lower cost collect hardware platforms
- Comprehensive API for custom application development
- C++, and C# example source code

CAPTURE

- Control image acquisition and data formats
- Control camera settings such as auto exposure, resolution, and frame rate
- Configure GPIO trigger or strobe settings
- Adjust JPEG compression settings to fit data throughput requirements
- Acquire and save synchronized images and GPS data to disk

PROCESS

- Hardware accelerated image rectification, processing and stitching pipeline
- Perform image processing such as debayering, exposure compensation, white balance, gamma and tone mapping
- Render output using panoramic, dome or cube map
- Retrieve camera intrinsic and extrinsic data for photogrammetry applications
- Dynamically select different stitching distances for different areas of the scene

OUTPUT

- Export processed images to a variety of still image and video file formats
- Encode H.264, H.265, VP9, WMV, FLV, AVI video
- Generate Google Map, Google Earth or raw GPS data files



a. Panoramic view b. Spherical view c. Dome view d. Multi-camera view

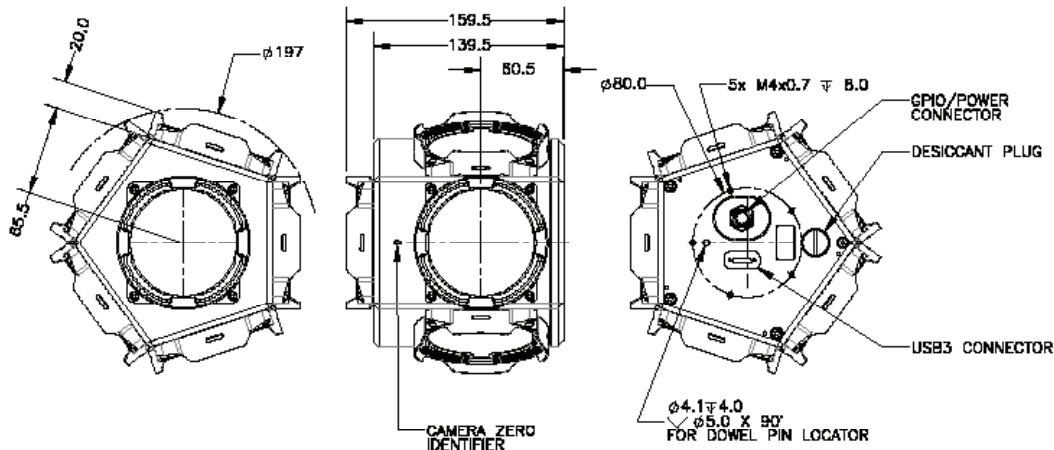

FLIR Integrated Imaging Solutions

CANADA

12051 Riverside Way
Richmond, BC, Canada
V6W 1K7
T: +1 866.765.0827 (toll free)
T: +1 604.242.9937
F: +1 604.242.9938
E: mv-sales@flir.com
www.flir.com/mv

EUROPE

T: +49 7141 488817-0
F: +49 7141 488817-99
E: mv-eusales@flir.com

CHINA

T: +86 10 8215 9938
F: +86 10 8215 9936
E: mv-chinasales@flir.com

USA

T: +1 866.765.0827 (toll free)
E: mv-na-sales@flir.com

ASIA

E: mv-asiasales@flir.com

For a full list of international distributors and offices visit www.flir.com/contact-us

©2017 FLIR[®] Integrated Imaging Solutions Inc. All rights reserved. Names and marks appearing on the products herein are either registered trademarks or trademarks of FLIR[®] Systems, Inc. and/or its subsidiaries.