

E

D

C

B

A

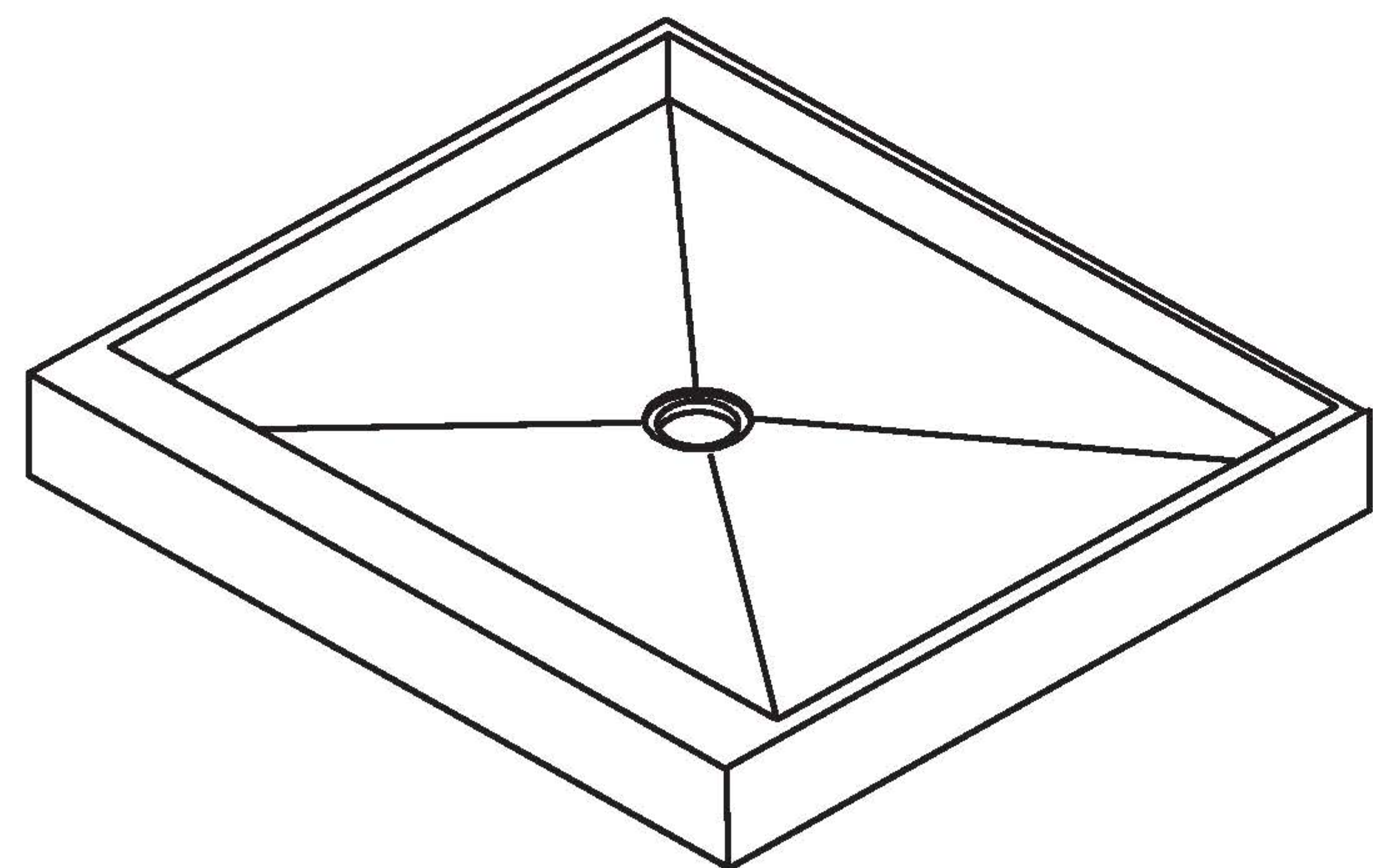
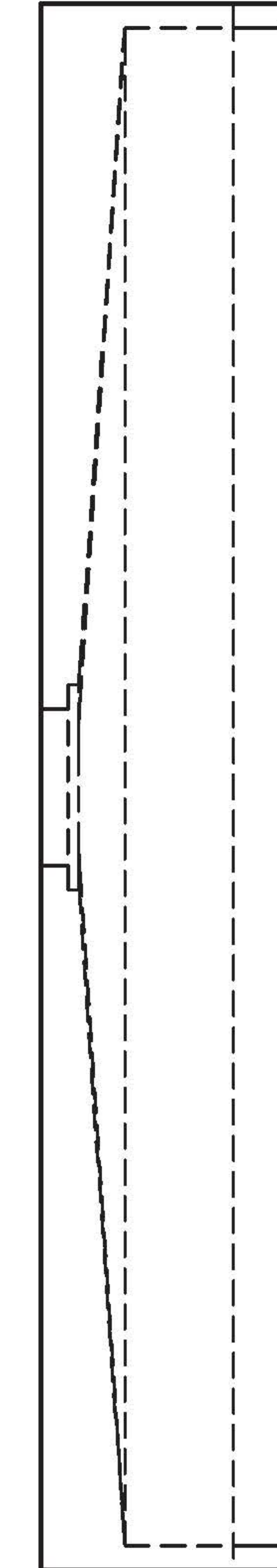
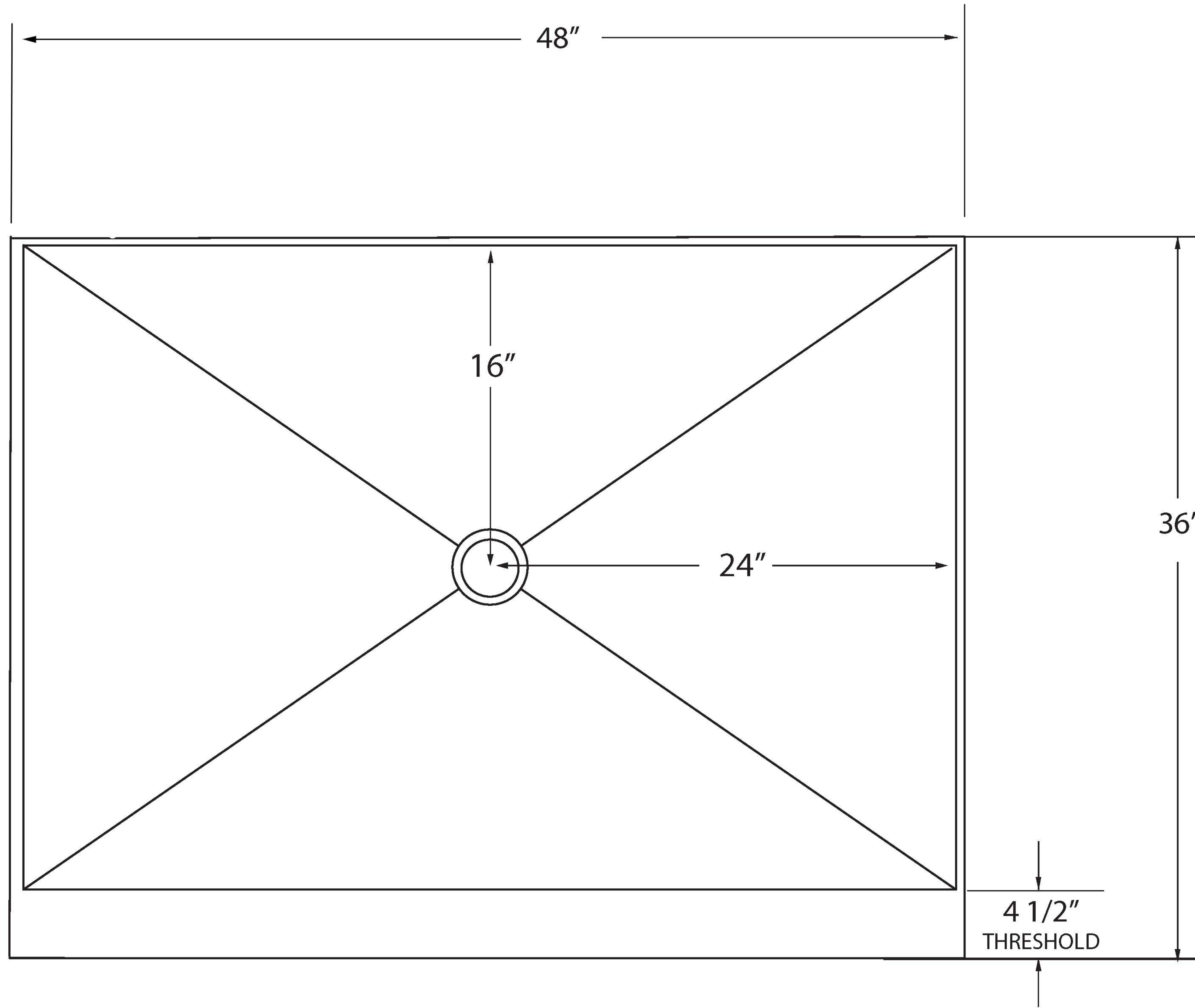

SCALE 1:25

NOTES:

DO NOT USE ANY PRODUCT SPECIFICATIONS TO BEGIN INSTALLATION BEFORE RECEIVING PRODUCT. THESE SPECIFICATION SHEETS ARE FOR REFERENCE ONLY. USE ACTUAL PRODUCT MEASUREMENTS ONLY.
(OVERALL DIMENSION TOLERANCE IS +/- 1/4")

UNLESS OTHERWISE SPECIFIED
DIMENSIONS ARE IN INCHES. TOLERANCES
ARE
X.X = ± 0.1 FRACTIONAL = ± 1/4"
X.XX = ± 0.01 ANGULAR = ± 1/2"
X.XXX = ± 0.005



SHOWER PAN

		NAME	DATE	SIZE	PRT. NO.	REV
DRAWN			7/17/2014	A	S483604XX-C	D
CHECKED						
ENG. APPR.				SCALE: 1:10	FINISH: ALL	SHEET 1 OF 1

1

2

3

4

5