

# Sistine Stone™

## CORNER

Corner Shower System Installation Guide for Basic & Grand Hinged Packages

**Congratulations on the purchase of your new shower package. This guide will give you the instructions on the installation of your new shower.**

Sistine Stone™ showers are ideal for an experienced "DIYer". Please read through this entire installation guide before beginning your installation. If you feel you can not confidently install this shower by yourself hire a licensed contractor, handyman, or professional installer that can do it for you. Installation time may vary depending on your experience, complexity of shower, and "Pre-Install Prep Work" which may include: plumbing and/or drain relocation, bathroom demolition, and squaring up studs and floor.

**Watch our Installation and Product Videos on [americanbathfactory.com/pages/videos](http://americanbathfactory.com/pages/videos)**

Prior to demolition, scheduling your installer, or building your shower, double check that you have all the parts from the factory. Some applications may require a licensed plumber or contractor. Do not use any product spec sheets to begin installation before receiving product. These spec sheets are for reference only. Use actual product measurements only. The diagrams throughout this guide illustrate a 48" x 36" shower with a hinged door. Depending on the size of the shower purchased, actual parts may vary in size from the diagrams shown.

Our goal is to help you achieve a quick and successful shower installation.



See the clock in each section for estimated installation time.

**Please inspect shipment thoroughly upon receipt and before starting the installation. Missing or damaged hardware and tiles should be reported within 24 hours of receiving this shipment. If you need assistance, call 1-800-454-2284 Mon - Fri from 7:15am - 4 pm (PT)**



# 1

## CHECK YOUR SHIPMENT AGAINST APPROPRIATE PACKING LIST

Make sure you have received all the items necessary for the installation. This will also familiarize you with all the parts and hardware you will need to install your shower. Package contents are dependent upon which package you ordered.

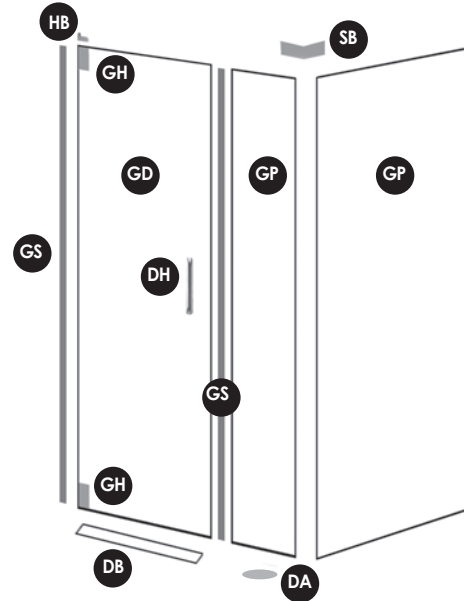
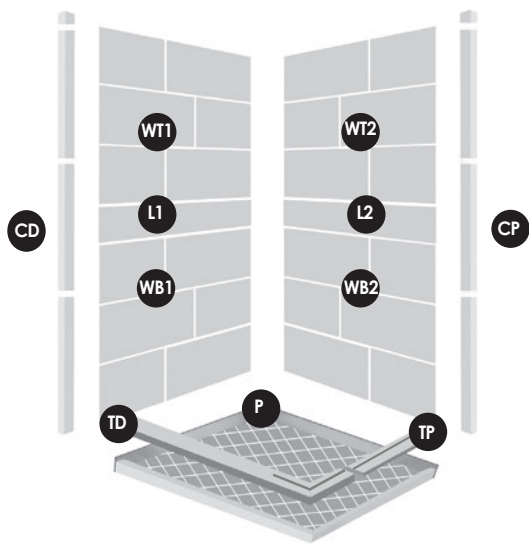

### SISTINE STONE PAN

- P** Metal Leak-Free Reinforced Pan
- TD** Threshold for Door
- TP** Channel Threshold for Glass Panel (2 pcs.)

### SISTINE STONE WALL PANELS

- WB1** **WT1** Left Wall Panels (2)
- WB2** **WT2** Right Wall Panels (2)
- L1** Left Solid Stone or Mosaic Liner (1) Right
- L2** Solid Stone or Mosaic Liner (1) Casing for
- CD** Glass Door (3) & Cap Side Casing for
- CP** Glass Panel (3) & Cap

✓ Store panels and liners on a clean, flat surface only, as well as all stone items. Leaning panels against a wall will cause them to bow. Laying them out will also allow the pieces to acclimate.

✓ **CAUTION:** Do not use an elastomeric waterproofing membrane on your backer board as silicone will not properly stick to it.

### HINGED GLASS DOOR SET

- GD** Glass Door
- GP** Fixed Glass Panels (2)
- DH** Door Handle
- GH** Hinges Top & Bottom (Installed)
- DB** Door Bottom Sweep
- GS** Door Seal/Stop (2)
- DA** Drain Assembly (may be sold separately)
- HB** Top Hinge Wall Bracket
- SB** Corner Support Bracket

✓ **CAUTION:** handle glass door and glass panels with care. Glass is heavy and fragile.

For best results, keep direct water sprays (handshowers/showerheads) away from the door. Never install them directly opposite of the door or opening. The vulnerable area of a frameless shower enclosure is the door, so keeping direct water spray away will ensure you have minimal water escaping.

## OPTIONAL ITEMS



FAUCETS



SHAMPOO BOX

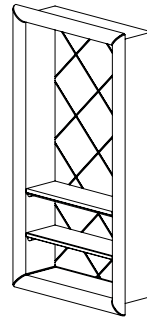

SHOWER BENCH

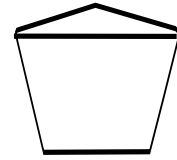

2

### PRE-INSTALLATION TEAR DOWN



TIME REQUIRED  
**8-16 HRS**

This shower system is designed to be installed on a level, bare floor. It is necessary for any existing shower to be completely removed. Tear out and remove all old material to expose the 2 x 4 wall studs. Clean up the shower area, removing all dust and old material from the area.

**Cold Weather Warning:** We recommend not installing your shower below the temperature of 70°F. The shower will be fine in cold weather after installation, but during installation bending and handling shower components in cold weather can cause breakage. Frigid conditions can make some shower components brittle and susceptible to cracking during rough installation handling.

3

### DRY-FITTING THE PAN



TIME REQUIRED  
**1/2 to 1 HR**

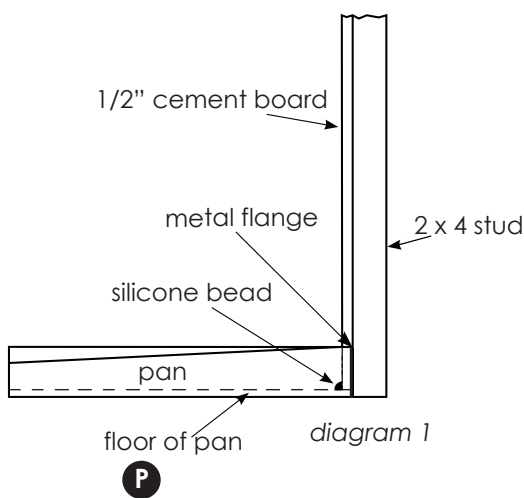

It is easier to check alignment of studs and pan without the drain installed into the pan.

Place the pan in the planned position. Check to see that the spacing between the metal pan flange and 2 x 4 studs are flush. Some shimming or sanding of the 2 x 4 studs may be required to flush the studs with the metal pan flange. When screwing in the 1/2" cement board the metal flange will pull fast to the studs, and will secure the metal pan in place. (dia. 1)

✓ **NOTE:** Due to some rough handling during shipping, you can water test pan before installation to check for any issues.

# 4

## 2 x 4 STUDS ALIGNMENT & POSITIONING



TIME REQUIRED  
1/2 to 1 HR

Using the pan and wall panels, you will be able to check to make sure your 2 x 4 studs are in the needed position and supported adequately. You will see in (dia. 2) extra 2 x 4 studs are added to the door and glass side thresholds for extra strength. You may need to make adjustments for your a shampoo shelf. When you place the bottom sections of the wall into the shower pan, you can also calculate the needed width and height of areas to keep free of 2 x 4 studs. (See installation instructions for shampoo shelf) This is also when you should add your extra support bracing for those who need them for your other accessories such as the shower valve, grab bars, benches or shelves.

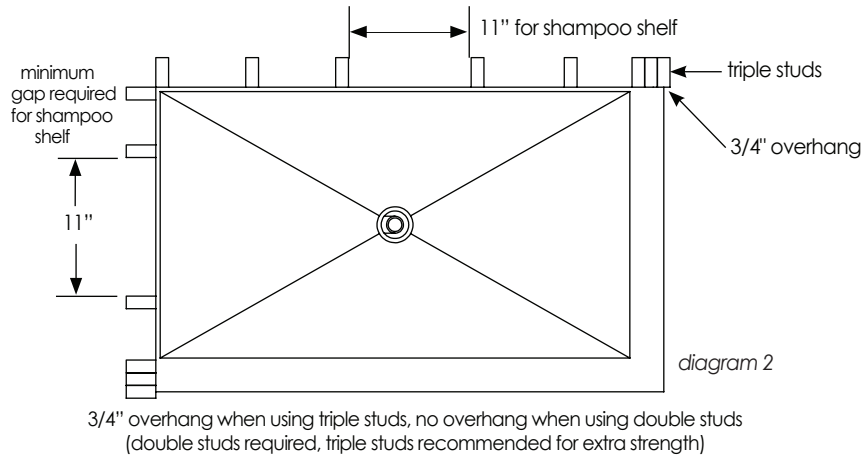

# 5

## INSTALLING DRAIN (may be sold separately)

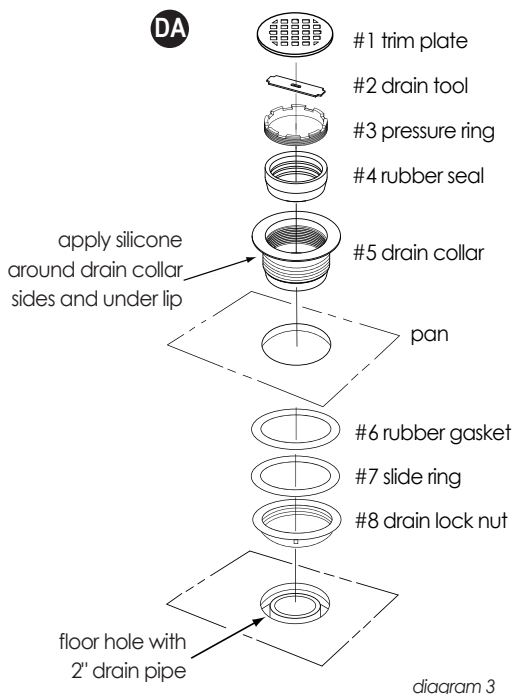

1. Locate the drain assembly **DA** to install into the pan **P**
2. Apply a generous bead of 100% RTV silicone around the shower pan drain hole and around the outside of the drain collar #5, insert the drain collar #5 into the drain hole.
3. Apply a generous bead of 100% RTV silicone around the drain collar #5 from the underside of the pan.
4. Install the rubber gasket #6 over the drain collar #5, to the underside of the pan, next install the slide ring #7.
5. Screw on the drain lock nut #8 and hand tighten. Turn drain lock nut #8 approximately 1/4 turn with the wrench to ensure a water-tight fit. Check for a good seal. **DO NOT OVERTIGHTEN.**
6. Wipe off excess silicone and allow silicone to dry. Follow the manufacturer's directions for application and drying time.

# 6

## SETTING PAN



TIME REQUIRED  
1/2 HR

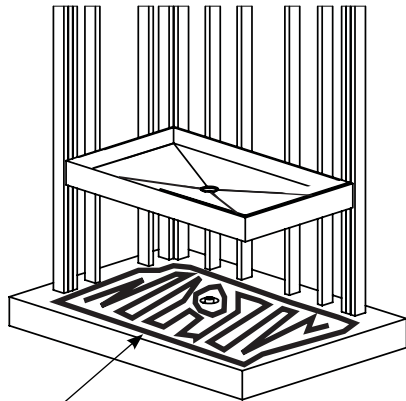

diagram 4

1. Now that the drain is installed into the pan dry fit the pan and drain for alignment, check to make sure the 2" drain pipe is in the center of the pan drain hole. (dia. 2) Use the drain collar #5 by itself; remove the rubber seal, nut and gaskets from the drain assembly. (dia. 3, previous page) Push the drain collar #5 into the drain hole between the pan and the 2" pipe. With the drain collar pushed flush to the pan surface, the 2" drain pipe should not extend past the inside threads of the drain collar #5.
2. Make sure the pan and drain fit level to the floor.
3. Remove pan and apply 100% RTV Silicone to floor. (dia. 4)
4. Carefully lift the shower pan and set into place. Make sure the ABS pipe is still centered.
5. Push and secure the rubber seal #4 onto the 2" ABS pipe.
6. Thread on the brass pressure ring #3 around the drain pipe with the provided tool #2. Remove the tool after the brass pressure ring is installed.
7. Test and snap the decorative diamond trim plate #1 into position. (Remove the decorative trim plate and store in secure area until installation is complete, drain will be grouted when shower is grouted)
8. After installing pan, cover with cardboard or drop cloth to protect pan from scuffs.

# 7

## CEMENT BOARD INSTALLATION



TIME REQUIRED  
1-2 HRS

We recommend the use of 1/2" thick cement board as your shower backer. This is a common backer for stone and tile. Using this backer will help comply with almost all city codes. A product like WonderBoard® or HardieBacker® may be used if it meets your local codes. Some codes may also require a vapor barrier to be installed. We recommend using a 6 mil. plastic water/vapor barrier and should be installed prior to the cement board. To do this, staple plastic so that it hangs 1" above the floor. **DO NOT USE AN ELASTOMERIC WATERPROOFING MEMBRANE ON YOUR CEMENT BOARD (such as RedGuard).** Roofing nails may be used to attach the cement board instead of screws, this prevents the plastic from wrapping around the screws.

**IMPORTANT:** Walls must be solid, plumb, and square within 1/8" of true. Use your cement board as an indicator of squareness. If you see gaps or areas where the cement board is not fitting flush, fix the problem by removing the cement board and shimming the boards until it's square and flush. This kit is designed with some allowances for minor alignment issues.

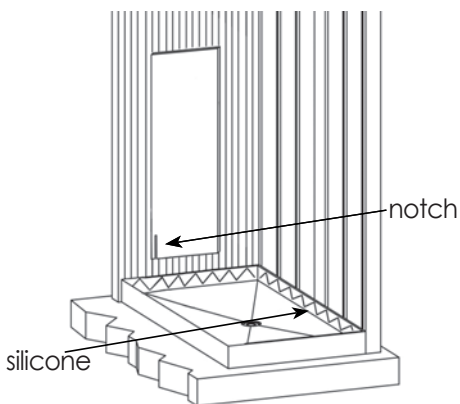

diagram 5

1. Cut a notch in cement board to fit around threshold flange. Sanding or shimming the 2 x 4's at the top rim of the pan may be required to flush the cement board. (dia. 5)
2. Place a bead of 100% RTV silicone on the front INSIDE face of the shower pan flange. The bead should be in a zig-zag pattern. (dia. 5)
3. Place the cement board against the studs and rest it inside the shower pan against the back flange. Attach the cement board to the studs with screws or nails. **DO NOT** screw or nail into the metal shower pan flange.
4. Continue installing the remaining cement board.
5. Clean the wall surface with a damp cloth to remove any dust, dirt, or any other contaminants.

# 8

## PAN & WALL THRESHOLD TRIM



TIME REQUIRED  
1/2 - 1 HR

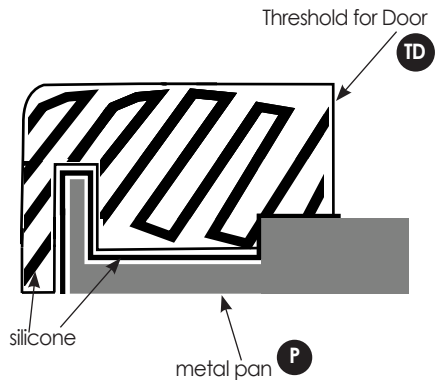

diagram 6

### A - Pan Threshold

1. Locate the threshold pieces **TD** **TP** (dia. 6 & 7)
2. Dry fit thresholds onto the front of the metal pan. The Door threshold does not have a channel in it. The door rail is reversible and can be placed on the left or right. (dia. 8)
3. Remove and place 100% RTV silicone in the Pan where the bottom of thresholds rest, and in the bottom channels under the thresholds, re-install thresholds into pan.
4. There will be a small gap between the bottom of thresholds and the floor, this can be grouted later if it is still exposed after installing bathroom flooring.

**Install TD & TP with inward slope so any water will drain back into the pan.**

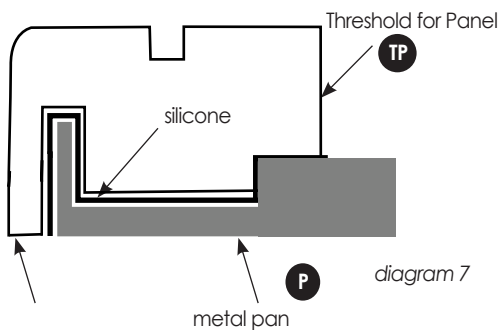

diagram 7

### B - Glass Door and Glass Panel Casing Trim

1. Locate **CD** glass door side casing.  
Locate **CP** glass panel channel side casing & cap. (dia. 9)
2. To help with the side casing installation, use a level and draw a plumb line from the inside of the pan threshold up to the top of the shower. Do this on both sides. This line will be where the side casings and the wall Panels meet, this will give you a visual reference point when dry-fitting your wall panels.
4. Apply 100% RTV silicone, using a circular pattern, to the cement board along the plumb line, approximately 4 inches wide, to the edge of the shower pan. (dia. 10)
5. Place the first side casing into position making sure to align the side rail with the vertical plumb line previously drawn on the cement board. Apply pressure to the side casing to bond it to the cement board. The side casing will be flush with the inside of the shower pan threshold and have a small gap where the pan threshold slopes. (dia. 11). You can shim the gap if needed. Make sure to also align the channels.
6. Place the remaining side casings into position, 3 to each side and cap. Use a level and the plumb line previously drawn on the cement board to align the side casings vertically.

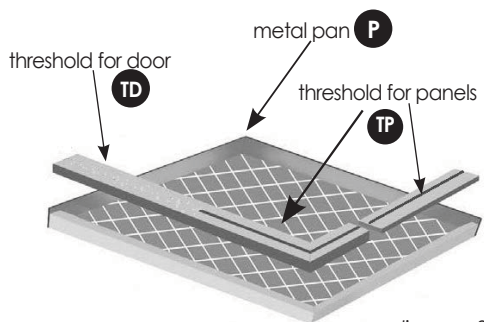

diagram 8

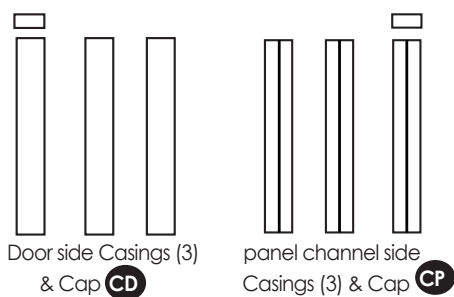

diagram 9

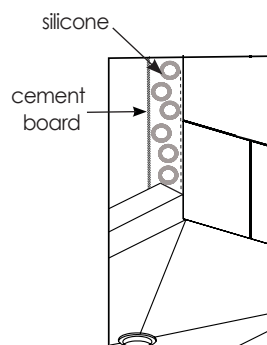

diagram 10

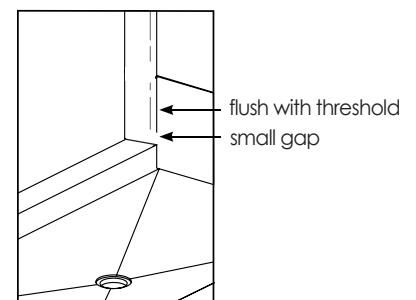

diagram 11



# 9

## WALL PANEL/LINER INSTALLATION



TIME REQUIRED  
**3-4 HR**

### A - Inspecting Wall Panels/Liners

Inspecting panels at this point will give you confidence that the wall panels are straight and square from the factory. When installing wall panels, you may need to make adjustments to the panels to accommodate for unevenness of your existing walls. During the inspection process and/or dry-fitting process, if you have any concerns about the alignment or fit of the wall panels, please call us and we will gladly assist you with your install.

1. Find a large flat area to layout and inspect all panels.
2. Align all panels and liners to check for straightness. Make sure grout lines are straight and square to each other.
3. Sistine Stone wall panels are made to be flexible and may have a slight bow. This condition is normal and wall panels will flatten out when properly installed. If wall panels have been stored improperly or have become excessively bowed, they can be corrected before installation. (See troubleshooting section on last page for details)

### B - Dry-fit Wall Panels/Liners

1. Place your first bottom back panel **WB2** into position. (dia.12) Rest onto the pan floor; use spacers between the floor and the panel to make the top of the panel level.
2. Place the back liner **L2** into position. Make sure the grout lines are aligned, use spacers to make the top level. Inspect the spacing between the wall panels and the side threshold plumb line.
3. Place the top panel **WT2** into position, push the two panels together. Make sure the grout lines are aligned, use spacers to make the top of the panel level. Inspect the spacing between the wall panels and the side threshold plumb line.
4. Depending on your cement board alignment, some sanding of the wall panel edges may be required for a tight fit.

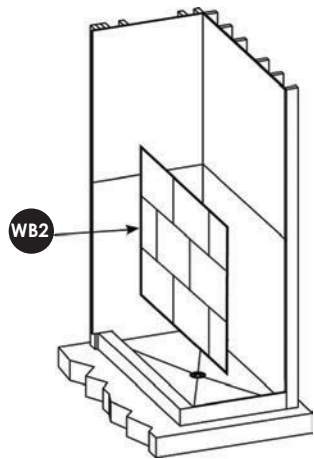

diagram 12

**DO NOT force the panels or liners to fit in a tight space. This will cause the panels to bow or curve and can cause them to break. Due to the resilient flex in the panels any bowing will cause the silicone bond to break away from the wall's surface.**

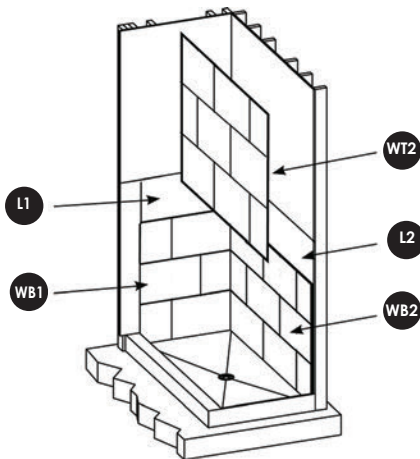

diagram 13

5. Holding the upper panels and liner in place with another persons help, check the length and overlap alignment. Some fitting may be required.
6. Place one of the bottom side panels **WB1** into position and check for levelness and length.
7. Place the side liner **L1** into position. (dia. 13)
8. Place one of the top side panels **WT1** into position.
9. Repeat steps 6 through 8 for other side of shower.
10. Depending on your faucet selection, you may need to mark and cut out holes for your faucet and other accessories (i.e. shampoo shelf) to fit through before you can place the panel into position. Remember "measure twice, cut once", you can cut our walls with most cutting tools.

**HELPFUL HINTS:** Place wall panels on a flat surface finished side up and put masking or painter's tape where the blade will cut the stone. All cutouts for faucets or accessories should have rounded corners; as sharp edges can cause stress cracks. For best results when drilling, place a scrap piece of wood beneath the hole to ensure a clean cut. In cooler climates, use extra caution when cutting and handling the panels because they won't flex as well when it is cold.

See installation video at [americanbathfactory.com/pages/videos](http://americanbathfactory.com/pages/videos)

# 10

## WALL PANEL/LINER INSTALLATION (continued)



TIME REQUIRED  
**3-4 HR**

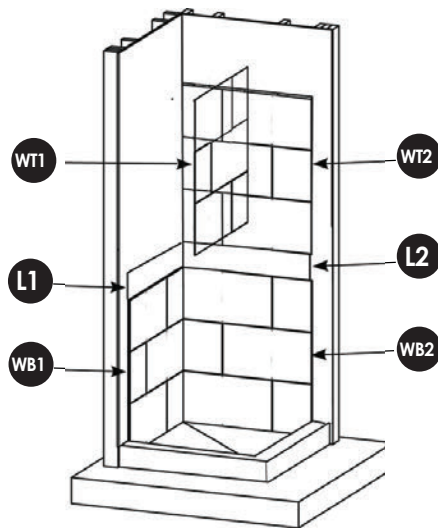

diagram 17

### C - Installing Panels

1. Remove all dust and dirt with a clean dry cloth. This will increase the bond to the 100% RTV silicone.
2. Start with the bottom panel **WB2** apply a generous amount of 100% RTV silicone to the cement board and to the back side of the wall panel. Refer to the manufacturer's recommendations for application and drying time.



**Braces may be required to keep walls flush**

3. Press the wall firmly into position. Be sure to use spacers between the bottom panel and the shower pan to ensure panel is level. (diagram 17)
4. Install the remaining panels in the following order:



5. Match the space between the panels with the rest of the grout lines on the panel. Use spacers if necessary to make the walls square and straight.

# 11

## OPTIONAL SHAMPOO SHELF INSTALLATION



TIME REQUIRED  
**1/2 - 1 HR**

1. The Shampoo Shelf was designed to match your tile size. 12" x 24" tiles, the cut-out hole size is 10 x 22".
2. There is a 1" lip or frame around the Shampoo Shelf, this will be the water sealed area for the Shampoo Shelf.
3. The best way to cut the hole is with a small 5" round diamond blade and with a jigsaw to cut the corners.  
**See detailed instructions enclosed with Shampoo Shelf**
4. On the 2 tiles the Shampoo Shelf will be replacing, mark 1" from the outside of the grout line, the cut-out area will be 10" x 22". Cut out the hole for the Shelf. The smaller the hole the better.
5. Dry-fit the Shampoo Shelf for alignment of grout lines.
6. Using 100% RTV Silicone in-place with a generous bead around the back of the lip, wipe off excess silicone with tissue.



# 12

## GLASS DOOR HANDLE & HINGE INSTALLATION

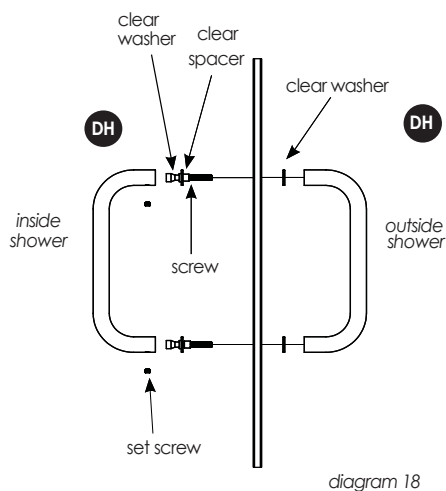

diagram 18

### A - Handle Installation

1. Set the glass door in a position to enable the assembly of the handle.



Be careful not to rest the edges of the door on hard surfaces. Tempered glass is very strong and impact resistant but its weakest point is impact on the edges.

2. Loosen the set screws so you can separate the handles.
3. Unscrew the long bolt from the handle. Keep all rubber pieces attached to the screw.
4. Remove the first set of flat, clear washers from the bolt.
5. Start with the top hole on the glass door. Place the long bolt through the hole in the door (keeping the remaining rubber pieces on the bolt). On the other side of the glass place the flat washers onto the threaded portion of the bolt. (dia. 18)
6. Take one side of the handle and screw the long bolt into the end. Just start the bolt until a few threads catch. Keep loose. (dia. 18)
7. Put the second bolt through the lower hole. Place the flat washer onto the bolt. Screw the bolt into the bottom handle. (dia. 18)
8. Align the handle on the door and carefully tighten the long bolts. Do not over tighten.
9. Place the opposite handle over the long bolts and tighten the set screws to secure the handle.

### B - Hinge Installation

1. Locate the top hinge **GH** and remove the side plate by loosening the two screws. (dia. 19)
2. Apply a generous amount of silicone onto the hinge and side plate.
3. Position the hinge onto the glass door lining up the holes so that the screws are on the inside of the shower door.
4. Attach the side plate with silicone applied to the glass and tighten the screws until the hinge is secure. Wipe off the excess and allow to dry.
5. Repeat these steps for the bottom hinge.
6. You will also find a Vinyl Water Shield for the bottom hinge. This can be added in between the glass door and the side plate to help keep water in the shower should you have a smaller shower or a shower-head pointed towards the door. (dia. 19a) See Images below for illustrated installation examples. You may trim the Water Shield as needed.

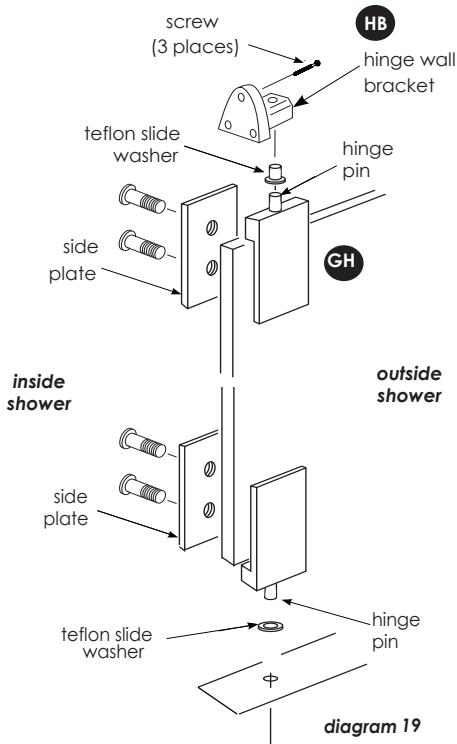

diagram 19

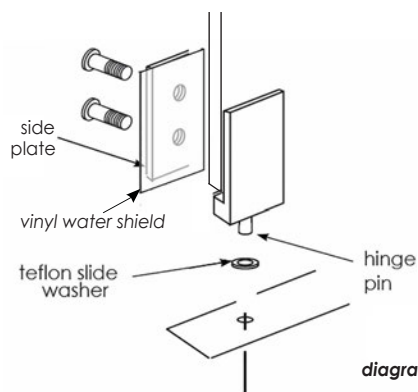

diagram 19a



## C - Dry-fit Fixed Glass Panel & Glass Door

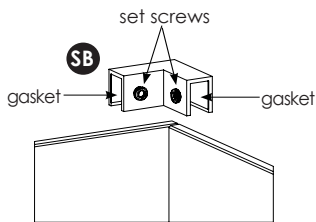

diagram 20

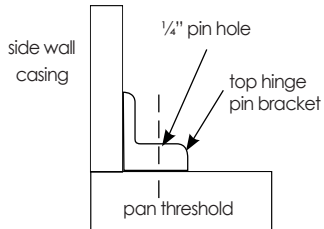

diagram 21

1. Gently insert the side glass panel into the channels. With someone helping you, place the door return glass panel into the door rail. Install the corner support bracket. (dia. 20) You will be adjusting the fixed glass panel so it's level with the door and has an even  $\frac{1}{4}$ " gap between the door and the glass panel. Use rubber setting block to adjust height and level if necessary.
2. Next, to determine the position of the bottom hinge pin hole, place the top hinge pin bracket upside down on bottom pan threshold as a template. (dia. 21) Align bracket hole to center of side glass panel. Mark the hole and remove the bracket. Carefully drill  $\frac{1}{4}$ " dia hole for hinge pin approximately  $1\frac{1}{4}$ " deep into the pan threshold.
3. Pick up the door you have installed the hinges and handle onto, and gently place the bottom hinge pin into the  $\frac{1}{4}$ " hole you have drilled into the pan threshold. (making sure you have the Teflon slide washer on the pin)

## D - Install Fixed Glass Panel & Glass Door

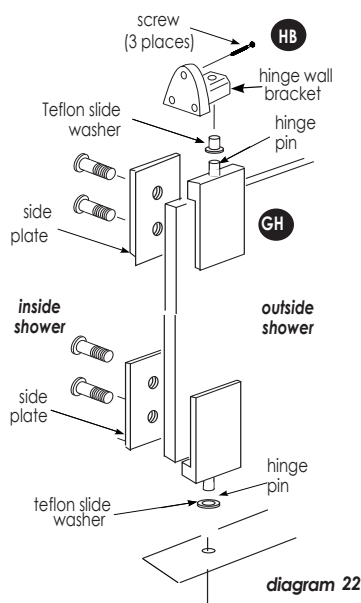

diagram 22

1. With someone helping to hold the shower door, place the top hinge mounting bracket (dia. 22) over the top hinge pin (making sure you have the Teflon slide washer on the pin). Check to make sure door is plumb and level, then mark with a pencil through the 3 holes on top hinge mounting bracket.
2. Move door and top hinge mount to one side and pre-drill the holes into the studs. The drilled holes should be large enough so the screws don't bind in the stone. Insert and tighten screws.
3. Next dry-fit the side panel into the correct alignment with the door, remove the glass and apply a  $\frac{1}{4}$ " bead of 100% RTV silicone into the channels. Re-insert the fixed glass panel and check alignment again. Allow the silicone to dry. You can silicone any gaps between the stone and glass to ensure water tightness.

## E - Install Door Sweep & Seals

Locate the clear door sweep and attach it to the bottom of the glass door. The reflective shield should face into the shower. (dia 23) **The door sweep is what keeps the door closed.** Adjust the door seal until the required tension is achieved. The door sweep has been cut to fit over the hinge. Cut off the excess length opposite of hinge side.

We have provided door seals for water sensitive areas such as wood floors. If glass panels and door are installed correctly with the proper spacing, outside water spillage will be minimal and the side seals won't be necessary.

If you would like to use these side seals, follow the steps below:

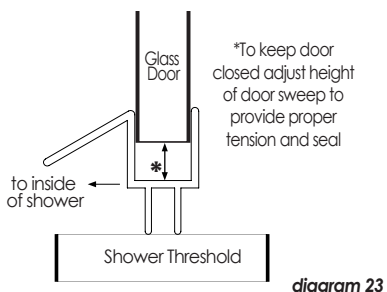

diagram 23

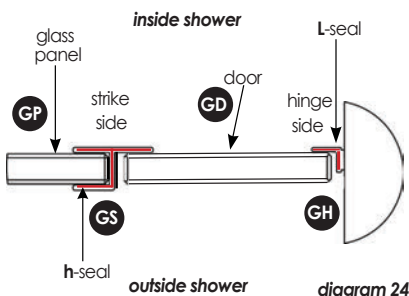

diagram 24

1. The L shaped seal goes along the hinge side of the door on the threshold trim pieces. (dia. 24)
2. Place the seal along the edge of the glass and cut the seal to the proper length.
3. Remove the backer from the seal exposing the double-sided tape, only remove a small amount at a time.
4. Starting from the top, align the seal along the edge of the door and stick the seal to the threshold.
5. Work your way down the door. Do small sections at a time, slowly peeling the backer off the seal.
6. Locate the plastic h-shaped seal. It goes on the fixed glass, next to the handle edge. (dia. 24) Measure and cut the seal to length.
7. Starting from the top, push the seal onto the glass panel, slowly working your way down.

# 13 GROUT

Your American Bath Factory shower has a non-porous surface, which makes it easy to clean. Grout used must contain an ACRYLIC ADDITIVE to ensure proper bonding to the tiles. We suggest grouting in every union joint of shower components. Decorative lines in the shower walls and floors can be grouted if preferred, but it is not necessary.

1. Recommended grout: We Recommend a water based non-sanded Tile Grout in a caulking tube not "silicone caulk". You may also use powdered non-sanded grout, but we'd suggest using an acrylic additive to aid adhesion.
2. Make sure you do not let the grout dry completely onto the shower before removing and cleaning off the excess grout. If grout is allowed to dry onto the shower components, it will likely be difficult if not impossible to remove without damaging the shower's surface.

**Note: Grout is not covered by ABF Warranty.**

## CARE & MAINTENANCE OF YOUR SHOWER SYSTEM

**DO NOT CLEAN SISTINE STONE WITH PAINT THINNER, ACETONE, LACQUER THINNER, M.E.K., SCRUBBING BUBBLES** or other chemicals that attack the structural integrity of Resin Based Stone. Use of these chemicals will destroy the surface of the stone and void your warranty. Soapy water, ammonia based cleaners & Comet will remove most dirt and residue from all types of finishes. For stubborn stains you may use a non-abrasive Scotchbrite pad. "Lightly" scrub the stained area in a circular motion to avoid discoloration. The stone is naturally waterproof and will not absorb spills or soil, simply wipe away with a damp sponge. Periodic cleaning with a sponge and warm, soapy water will remove any build up of dust or grime. Periodically check the grout and silicone for any cracks and repair as needed.

## SHOWER SYSTEM TROUBLESHOOTING

**Correcting Bowed Wall Panels** Sistine Stone Wall Panels are made to be flexible and may have a slight bow. This condition is normal and the panels will flatten when properly installed. If the panels have been stored improperly or have become excessively bowed, follow instructions below. Using a hair dryer or heating pad/blanket, warm up the backside of the panel in the most bowed area. Once the panel becomes malleable, lay panel on a flat surface and apply weight until cool and flat.

**Cracked Tile** As with any tile project, a tile can become damaged. Simply cut out the damaged tile, silicone a replacement tile in place, and grout.

**Cracked Wall Panel Seam** If your wall panel developed a crack in a grout line, simply grout over the cracked seam when it is installed. The grout will correct the problem, you will not be able to tell the crack was ever there.

**Scratches & Blemishes** Can be removed by wet-sanding the tile surface. Make sure tile surface and sandpaper are wet, and sand tiles until scratches and blemishes are removed.

**Door Will Not Stay Closed** Adjust height of door sweep to provide proper tension and seal.

**Door Leaking** The shower doors are designed not to leak under normal usage when installed properly, and the water flow is not pointed directly at the vinyl seals, hinges or opening.



13405 Estelle Street, Corona, California 92879  
Phone 800.454.2284 Fax 951.734.1480  
Visit us at [www.americanbathfactory.com](http://www.americanbathfactory.com)