

# OVERALL & WALL STUD DIMENSIONS

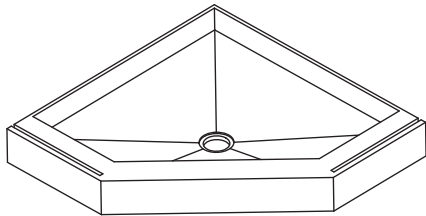
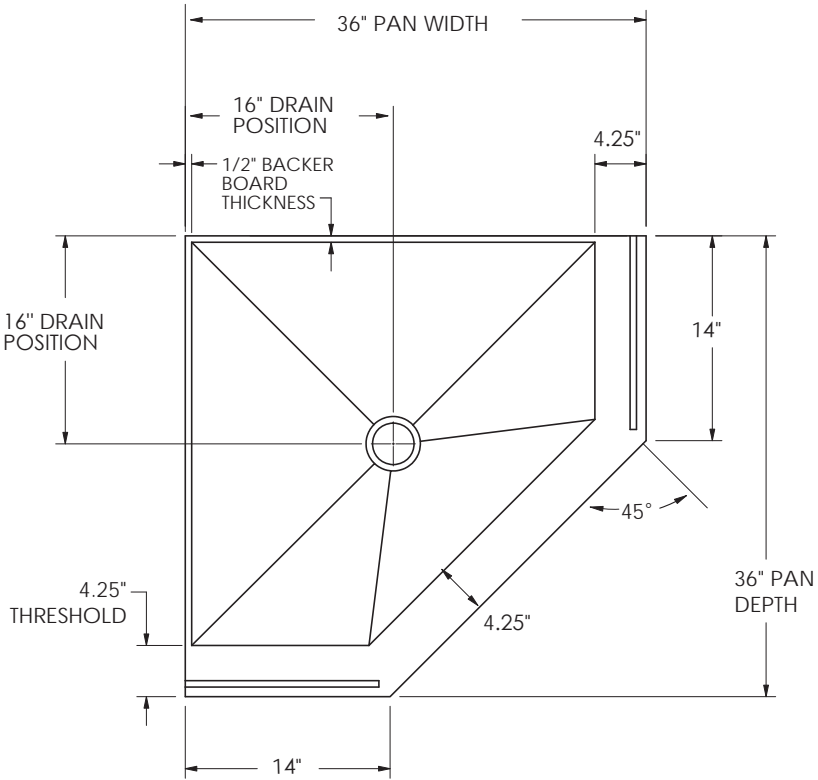
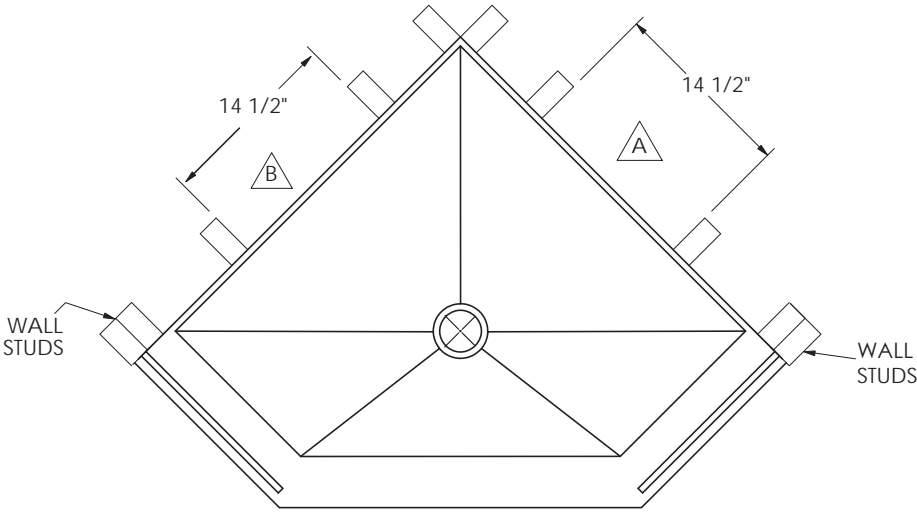

SCALE 1:20

**NOTES:**

- A** MINIMUM GAP REQUIRED FOR SHAMPOO SHELF.
- B** MINIMUM GAP REQUIRED FOR SHAMPOO SHELF.

**C** DO NOT USE ANY PRODUCT SPECIFICATIONS TO BEGIN INSTALLATION BEFORE RECEIVING PRODUCT. THESE SPECIFICATION SHEETS ARE FOR REFERENCE ONLY. USE ACTUAL PRODUCT MEASUREMENTS ONLY. (OVERALL DIMENSION TOLERANCE IS +/- 1/4")

UNLESS OTHERWISE SPECIFIED, DIMENSIONS ARE IN INCHES TOLERANCES ARE:

X.X = ± 0.1      FRACTIONAL ± 1/16"  
 X.XX = ± 0.05      ANGULAR: ± 1/2°  
 X.XXX = ± 0.010



SHOWER PAN SPECS, NEO-ANGLE 36 X 36-RC

PROPRIETARY AND CONFIDENTIAL  THE INFORMATION CONTAINED IN THIS DRAWING IS THE SOLE PROPERTY OF AMERICAN BATH FACTORY. ANY REPRODUCTION IN PART OR AS A WHOLE WITHOUT THE WRITTEN PERMISSION OF AMERICAN BATH FACTORY IS PROHIBITED.	ATTRIBUTES					
	SOURCE	MAKE	VOLUME	-	NAME	DATE
	COLOR	NATURAL	MASS	-	DRAWN	JA 4/9/2018
	MATERIAL	STONE		CHECKED		
	DO NOT SCALE DRAWING				ENG APPR.	

SIZE	PRT. NO.	REV
<b>A</b>	N363604-RC	F
SCALE: 1:15	FINISH: ALL	SHEET 1 OF 1