

# \*0" Double Nuevo

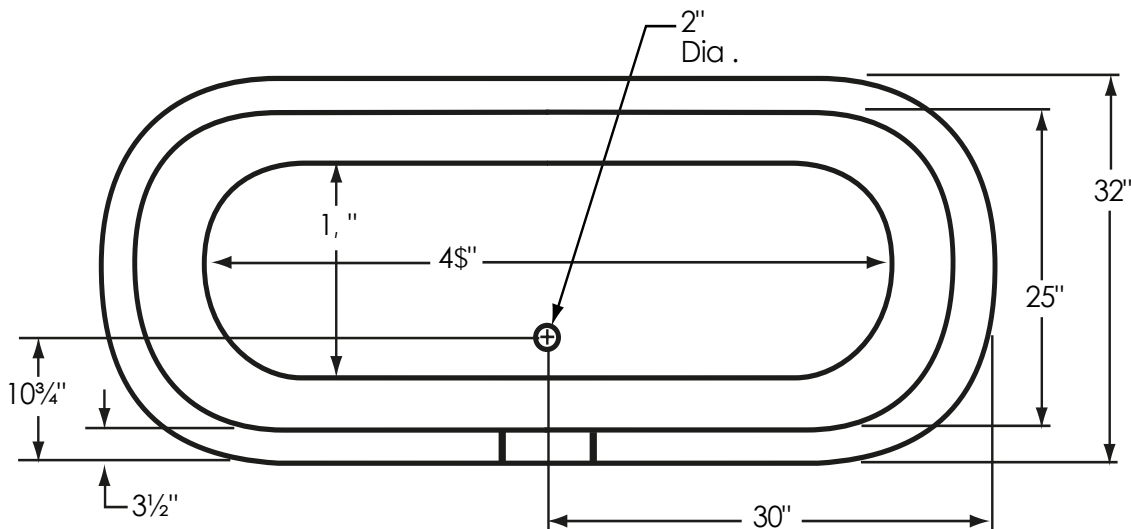

**Overall Dimensions:** \*0" L x 32" W x 25" H  
**Capacity:** ' \$ Gallons  
**Dry Weight:** 1\$0 lbs.  
**Full Weight:** ' 50 lbs.

All measurements are approximate. Dimensions shown have a tolerance of  $\pm\frac{1}{2}$ ". Dimensions shown not to scale.

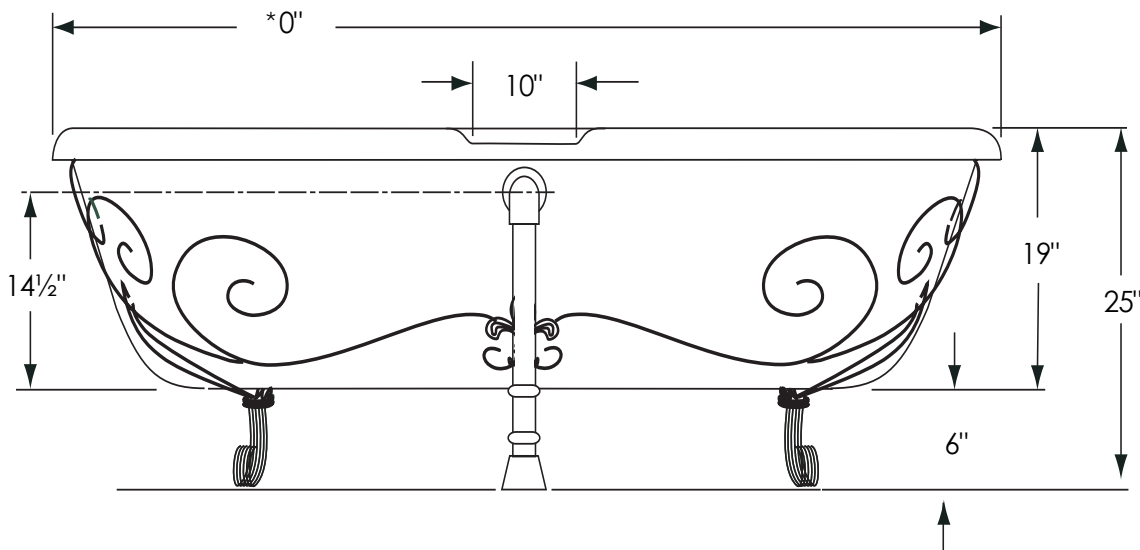
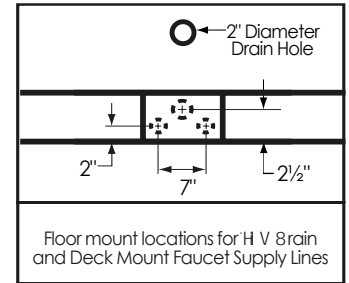

**Notes:** Please measure your actual product for rough-in details. All product dimensions have a tolerance of  $\pm\frac{1}{2}$ ". Install this product according to the installation instructions.

American Bath Factory reserves the right to make revisions without notice to product specifications. For most current specs, visit our site: [americanbathfactory.com](http://americanbathfactory.com)