

SLIM POWER

Compatible with E3D Slimline Stepper!

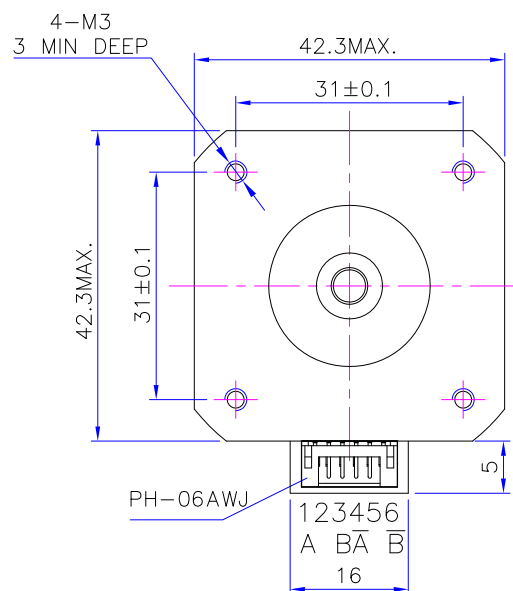

DIAGRAM

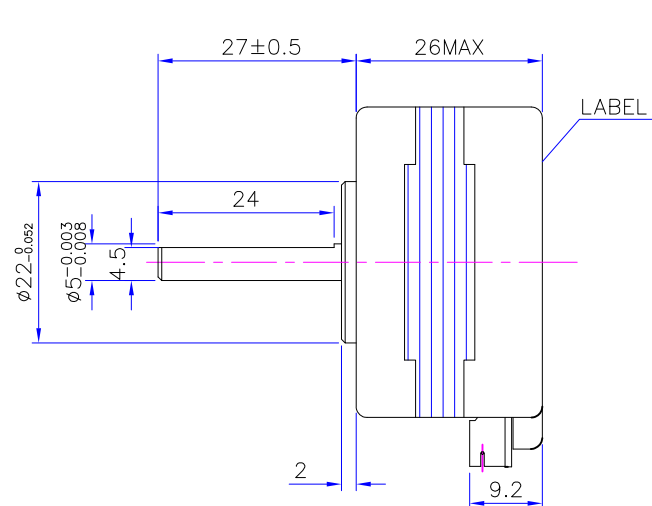
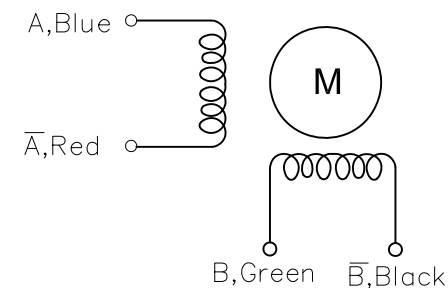

Label by laser print

**LDOMOTORS.COM**

0.9° Slim Power Stepper



LDO-42STH25-1404MAC

#YYMMDD

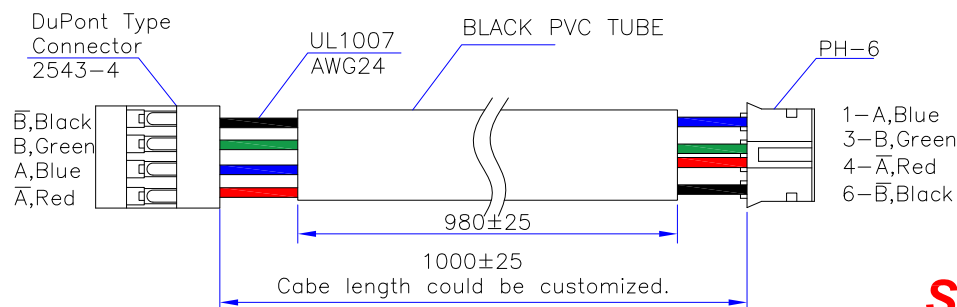
**SLIM POWER**

Items	Specs	Items	Specs						
Phase Number	2 phases	Rotate Direction	A-B-Ā-B̄-A CW						
Step Angle	0.9°±5%	HI POT	AC600V/1mA/1S	A	---	New Release	SD XU	J.B.	12/3/18
Resistance	2.4±15% ohm	Insulation Resistance	≥ 100 MΩ(DC 500V)	REV	ECN NO	Description	Made by	Approve	Date
Rated Current	DC 1.4 A /Phase	Insulation Class	Class B				LDO MOTORS CO.,LTD Hybrid Stepper Motor LDO-42STH25-1404MAC		
Holding Torque	≥18N.cm	Weight	0.15 Kg REF.						
Inductance(1Khz)	5.5±20% mH			Des.	Check	Appr.	Date	Factory Code	217HTNB2002-27
								page	