



ACCESSIBLE BATHROOMS

Deluxe Dual Massage Walk In Bathtub



93057 Left Hand Door and Drain



93058 Right Hand Door and Drain

Actual Size: 29.5" W x 55" L x 38" H
Shipping Size: 34" W x 59" L x 46" H
Shipping Weight: 320 lbs.
Net Weight: 220 lbs.
Water Capacity: 90 gal. US (unoccupied)
55-75 gal. US (occupied)

Options:

- Left or Right Hand Door/Drain
- Soaking
- Dual Massage with No Faucet (holes not drilled)
- 5 Piece Fast Fill Roman Faucet Set (Hot, Cold, Diverter, Hand Shower, Tub Spout)
- 5 Piece Traditional Roman Faucet Set (Hot, Cold, Diverter, Hand Shower, Tub Spout)

Included Features:

1. Tub Shell – Acrylic Tub Shell:
 - High quality cast acrylic grade A
 - Excellent color uniformity
 - 5 mm cast acrylic sheet
 - Fiberglass (reinforced)
2. Stainless Steel Frame
3. Low threshold step in 9.5" with the option to lower to 6.5"
4. Seat Width: 19.75"
5. Eight (8) adjustable heavy duty leveling legs
6. Stainless steel and tempered glass door, door frame and door seal gasket
7. Removable door for easy cleaning
8. Deck mount and wall mount two (2) safety grab bars
9. LED multiple color chromatherapy light with ON/OFF push control
10. Thermostatic control valve
11. Removable rubber back support (white)
12. Two (2) front, one (1) toe kick and one (1) side removable access panels
13. Wall extension kit to fit in standard 60" opening (extends to 59")
14. Air Massage System:
 - Ten (10) therapeutic air massage jets
 - 0.5HP air pump
 - ON/OFF push control

15. Hydro Massage System:

- Eight (8) adjustable and four (4) fixed hydro jets
- Air flow regulator for adjustable hydro massage
- 1HP pump (900 Watts)
- ON/OFF push control
- In-line water heater (1.5 KW)
- Ozone Sterilization (12 Volts) with ON/OFF push control

16. Brass 5 Piece Ella Faucet Set (Chrome Finish) designer spout, two 2 way diverters with ADA compliant handles, and pull out hand held shower with 5' retractable stainless steel hose

Plumbing:

- Two (2) x 4' long stainless steel braided water supply lines with 1/2" IPS connectors
- Two (2) x 2" floor drains with 2 overflows and 2 ADA compliant stainless steel cable operated openers with extension handles
- Drainage time +/- 80 seconds to overflow
- Two (2) PVC 2" drain elbows with 2" opening

Electrical:

Electrical requirement is one dedicated 120 V electrical line connection with a 30AMP dedicated GCFI breaker line connection.

Warranty:

- Lifetime limited warranty on frame, door, door seal gasket and acrylic walk in tub shell
- 5 Year parts warranty*

*For more information please visit www.ellasbubbles.com



ACCESSIBLE BATHROOMS

Deluxe Dual Massage Walk In Bathtub Features

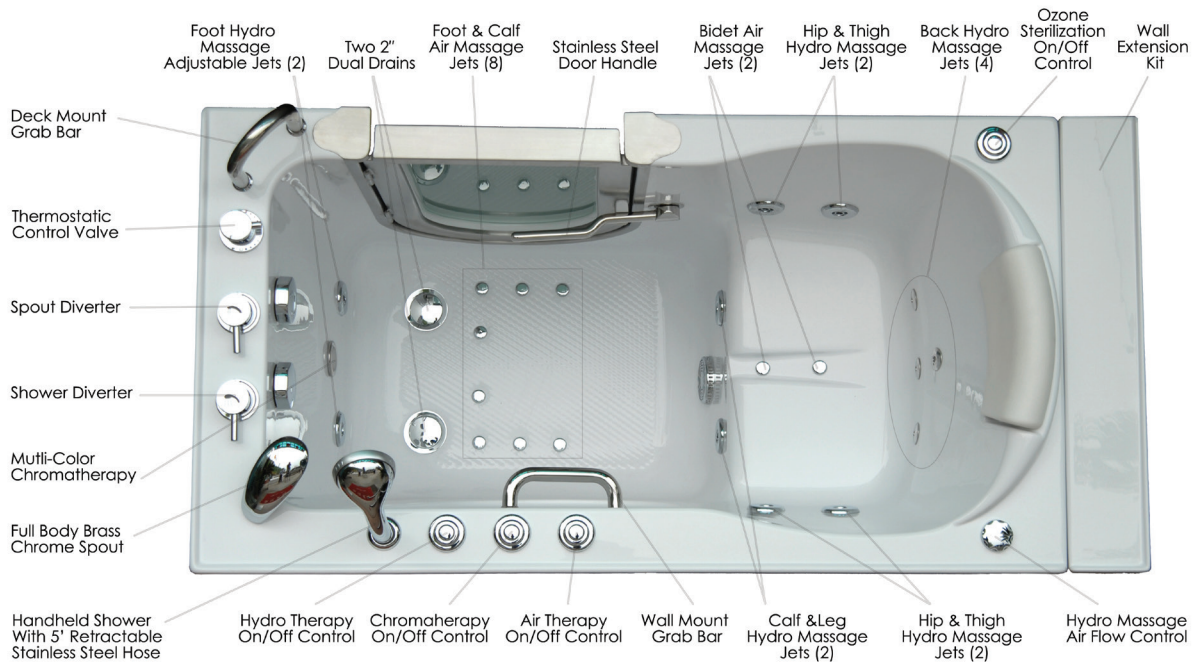
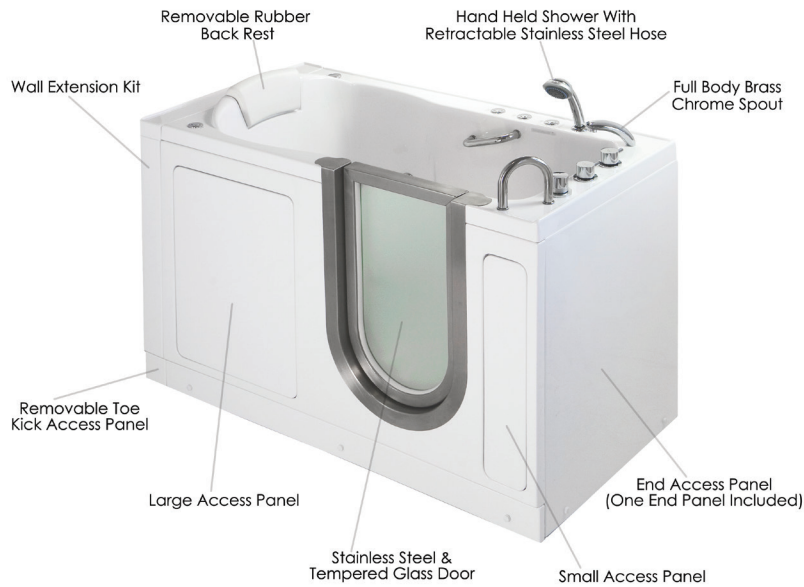

Panel On



Panel Off



Lowered Threshold



Baseboard On
(not supplied)



ACCESSIBLE BATHROOMS

Deluxe Dual Massage Walk In Bathtub

93057 L / 93058 R

*Right hand door and drain shown

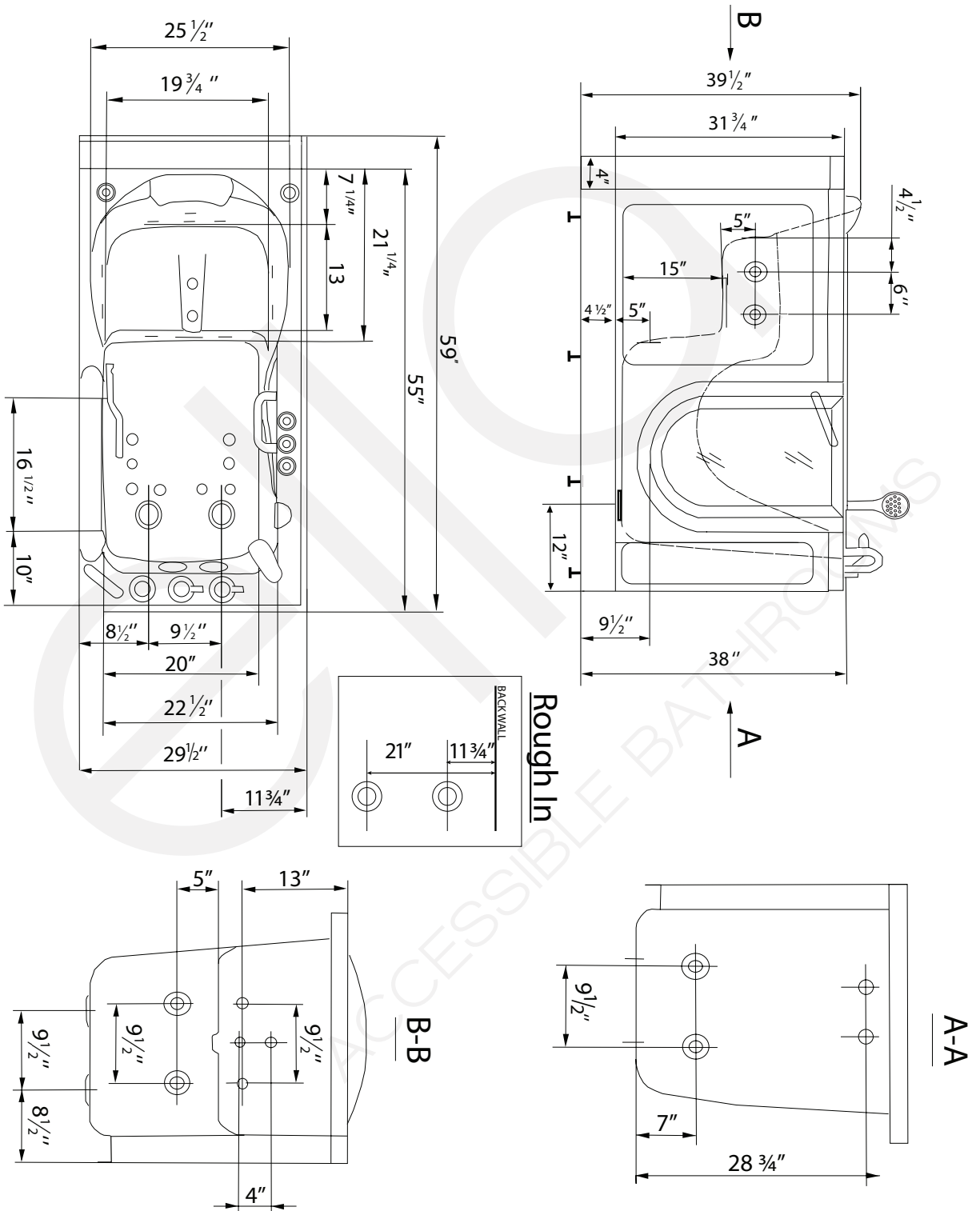

Disclaimer:

In an effort to continually improve our product, specifications and configurations are subject to change without notice. Before ordering or installing, consider future access to essential equipment.