



English / Englisch

Spare Parts

for the drum sanding machine

ELF

Lägler
www.laegler.com



00.200.20.802 01.01.2015

SPARE PARTS ELF

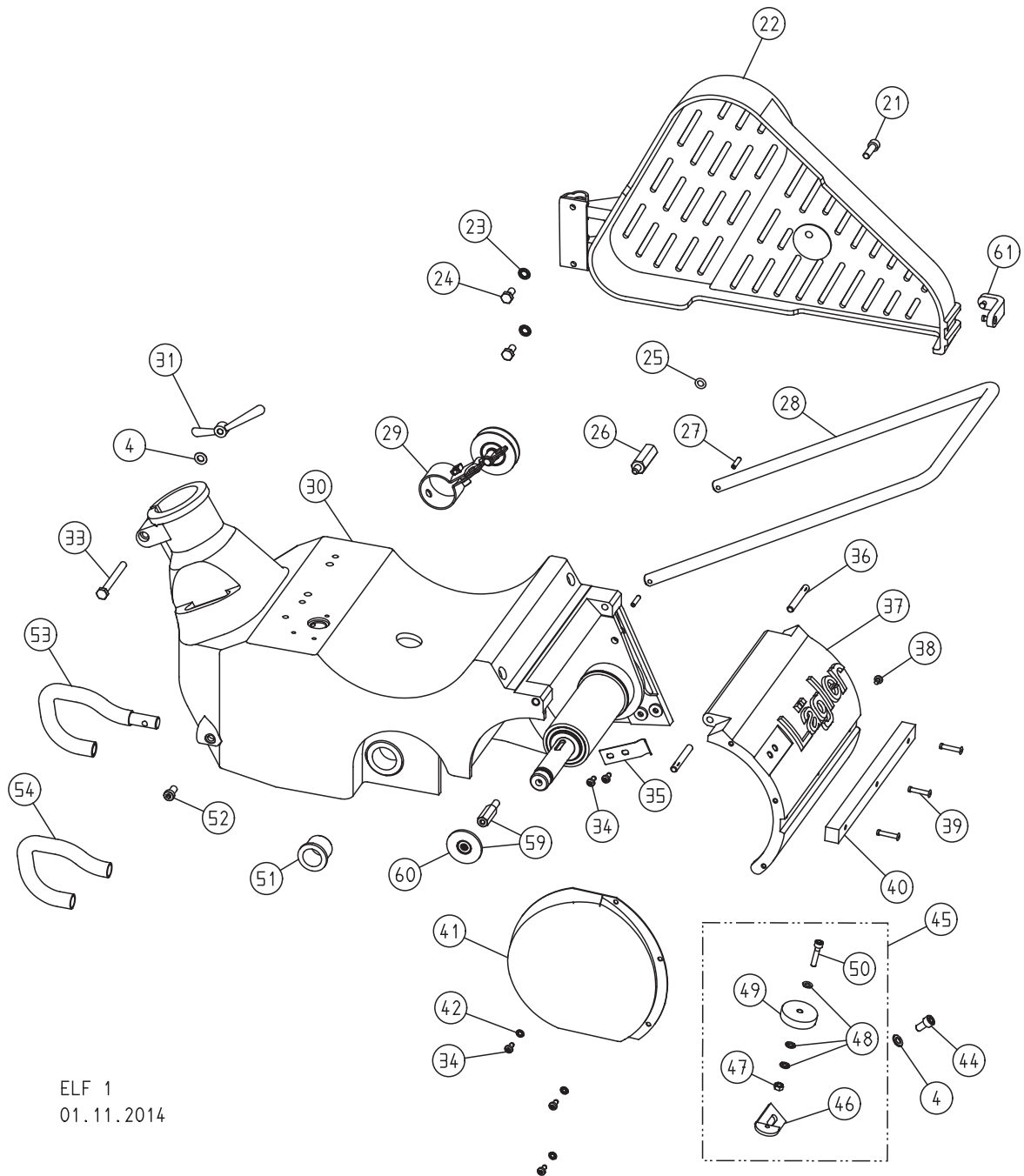

ELF 1
01.11.2014

SPARE PARTS ELF

Item	Part number	Description
4	0125.1008.000	Washer
21	0912.1008.025	Screw
22	100.50.00.100	Belt guard, complete
23	6797.1008.000	Washer
24	0933.1008.016	Screw
25	000.01.40.001	O-ring
26	100.50.04.105	Screw stud
27	1481.0005.022	Spring type straight pin
28	200.33.01.100	Bracket
29	100.58.00.200	Belt tensioner, complete
30	200.01.00.100	Housing ELF 200/250
	300.01.00.100	Housing ELF 300
31	000.20.45.083	Wing nut
33	0931.1008.075	Screw
34	7500.1005.012	Screw
35	200.01.05.100	Cover spring
36	200.01.07.100	Hinged pin
37	200.01.01.100	Drum cover ELF 200/250
	300.01.01.100	Drum cover ELF 300
38	7500.1005.008	Screw
39	7337.1005.033	Rivet
40	200.01.02.100	Bumper felt ELF 200/250
	300.01.02.100	Bumper felt ELF 300
41	200.01.03.100	Side cover ELF 200/250
	300.01.03.100	Side cover ELF 300
42	6797.1005.000	Washer
44	0912.1008.016	Screw
45	150.60.00.100	Wall-protecting roller with bracket ELF 200/250
	300.60.00.100	Wall-protecting roller with bracket ELF 300
46	150.60.01.100	Holder for wall-protecting roller ELF 200/250
	300.60.01.100	Holder for wall-protecting roller ELF 300
47	0934.1006.000	Nut
48	0125.1006.000	Washer
49	100.60.02.200	Wall-protecting roller
50	0912.1006.030	Screw
51	000.43.10.252	Plastic bushing
52	7984.1008.016	Screw
53	100.44.00.100	Safety guard, complete
54	100.44.01.100	PVC tube
59	200.01.30.100	Guide roller, complete
60	100.45.01.105	Guide roller
61	100.50.05.100	Bumper guard with rivets

SPARE PARTS ELF

Item	Part number	Description
1	100.00.80.105	Dust bag HUMMEL
3	000.17.21.081	Fixing cap
4	0125.1008.000	Washer
5	000.20.56.351	Ball knob
6	100.20.18.200	Lever
7	0471.0015.000	Circlip
10	0580.1008.000	Thread eye
11	0980.1008.000	Nut
12	00.000.41.002	Strain relief ring
13	100.20.26.100	Cable support, complete
15	100.20.01.200	Guide tube
	102.20.01.200	Guide tube USA
	100.20.00.200	Guide tube, complete
	102.20.00.200	Guide tube USA, complete
	100.21.00.200	Guide tube long, complete
16	100.20.24.100	Upper rod, complete
17	000.63.20.133	Rubber grommet
62	100.20.23.200	Adjusting ring, complete
65	000.20.31.351	Handle
66	0988.0015.005	Washer
67	0914.0008.012	Grub screw
68	100.20.17.200	Axle for handle
69	000.17.20.081	Quick-fixing-fastener

SPARE PARTS ELF

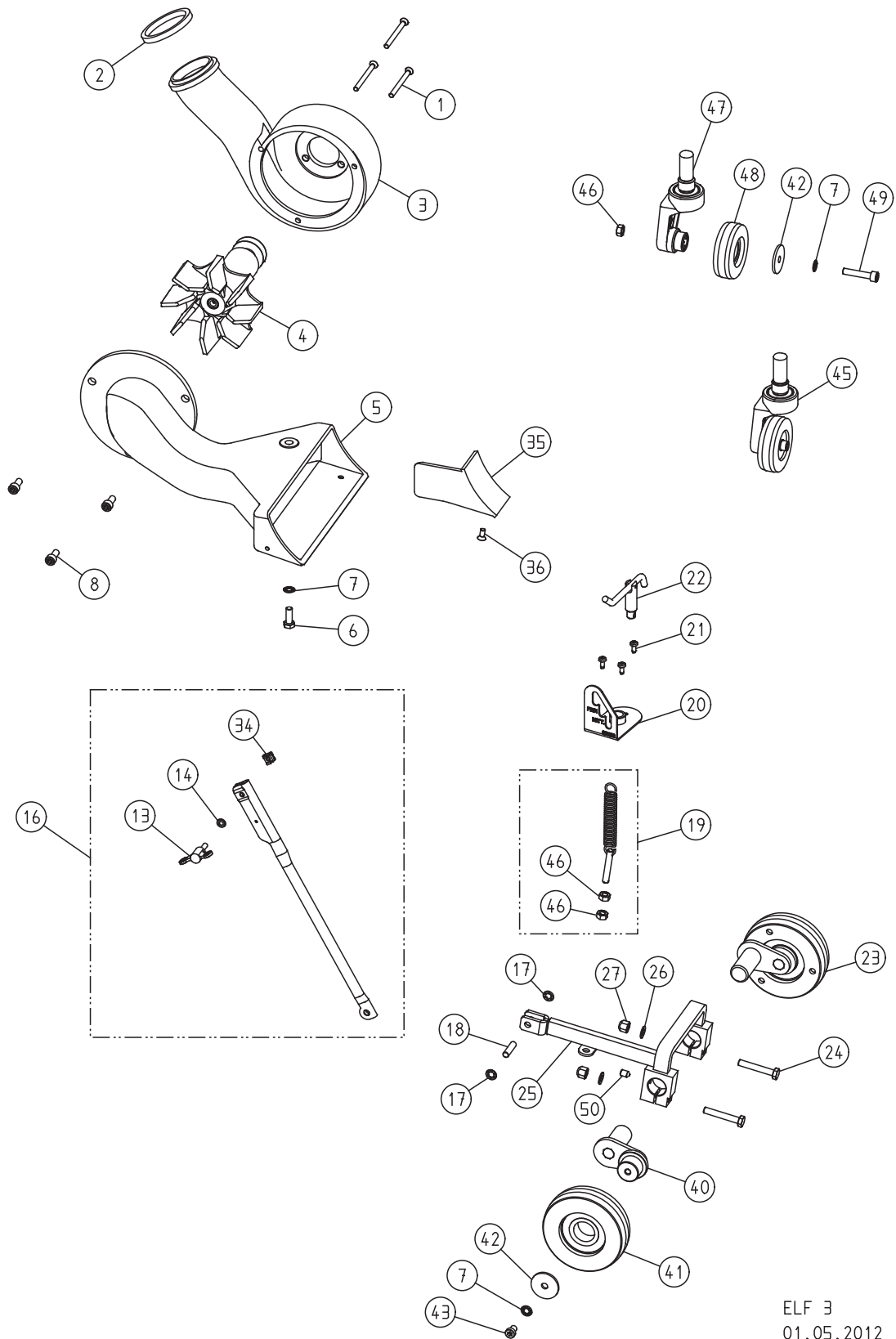

ELF 3
01.05.2012

SPARE PARTS ELF

Item	Part number	Description
1	0965.1006.870	Screw
2	200.08.01.100	Sealing ring
3	100.08.00.100	Fan housing
4	100.10.00.200	Fan insert, complete
5	100.14.00.100	Intake duct
6	0933.1008.022	Screw
7	6797.1008.000	Washer
8	0912.1008.018	Screw
13	000.20.46.062	Wing screw
14	0125.1006.000	Washer
16	100.04.09.100	Lower rod, complete
17	000.17.20.081	Quick-fixing-fastener
18	100.04.01.200	Pivot pin
19	100.04.25.100	Spring with screw, complete
20	100.04.06.200	Notch plate
21	7500.1005.012	Screw
22	100.04.02.100	Spring tensioner, complete
23	100.05.00.200	Lateral wheel, complete
24	0931.1008.050	Screw
25	100.04.00.100	Lifting fixture
26	0125.1008.000	Washer
27	6330.1008.000	Nut
34	000.50.12.061	Nut
35	200.14.10.100	Flow part
36	0965.1006.814	Screw
40	100.05.04.200	Wheel arm
41	100.05.29.100	Lateral wheel
42	000.10.10.085	Washer
43	7984.1008.012	Screw
45	100.18.00.300	Rear wheel, complete
46	0934.1008.000	Nut
47	100.18.18.300	Tail axle housing, complete
48	100.18.29.105	Rear wheel (from year of manufacture 2002)
	100.18.09.200	Rear wheel (up to year of manufacture 2001)
49	0912.1008.040	Screw
50	0914.0008.012	Grub screw

SPARE PARTS ELF

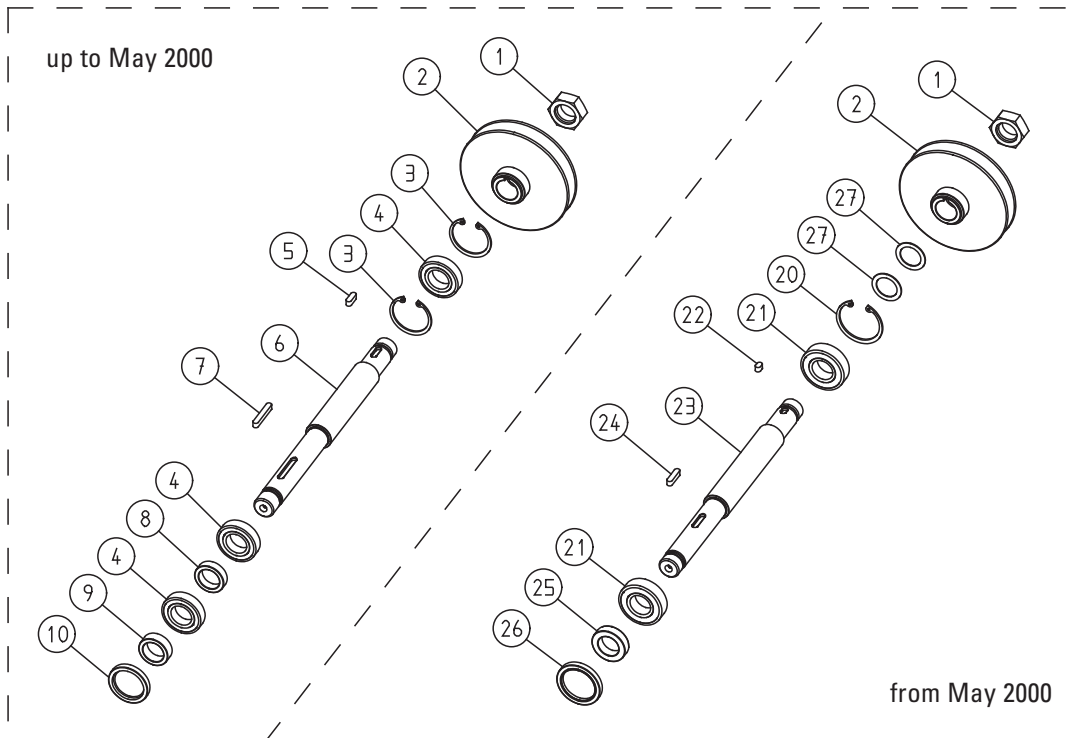

Please state the machine number with each order!

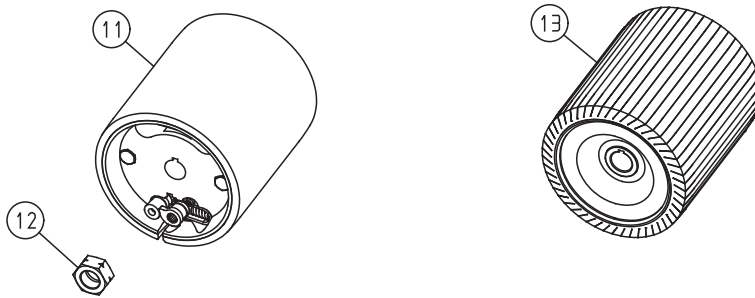

ELF 4
01.06.2013

SPARE PARTS ELF

Item	Part number	Description
1	100.02.05.100	Nut, right-hand thread
2	100.36.00.100	V-belt pulley
3	0472.0047.000	Circlip
4	6005.0025.205	Ball bearing
5	6885.0606.018	Parallel key
6	100.02.01.100	Sanding shaft
7	6885.0606.040	Parallel key
8	100.02.04.105	Spacer ring
9	100.02.03.105	Slide ring
10	000.11.35.102	Shaft seal
11	200.40.00.100	Sanding drum 200 mm, new
	200.40.00.109	Sanding drum 200 mm, exchange
	250.40.00.100	Sanding drum 250 mm, new
	250.40.00.109	Sanding drum 250 mm, exchange
	300.40.00.100	Sanding drum 300 mm, new
	300.40.00.109	Sanding drum 300 mm, exchange
12	100.02.06.100	Nut, left-hand thread
13	150.40.00.100	Centrifugal drum 200 mm
	300.41.00.100	Centrifugal drum 300 mm
20	0472.0052.000	Circlip
21	6205.0025.205	Ball bearing
22	6885.0606.010	Parallel key
23	100.02.01.200	Sanding shaft
24	6885.0606.025	Parallel key
25	100.02.03.200	Spacer ring
26	000.11.40.102	Shaft seal
27	0988.0025.010	Washer

SPARE PARTS ELF

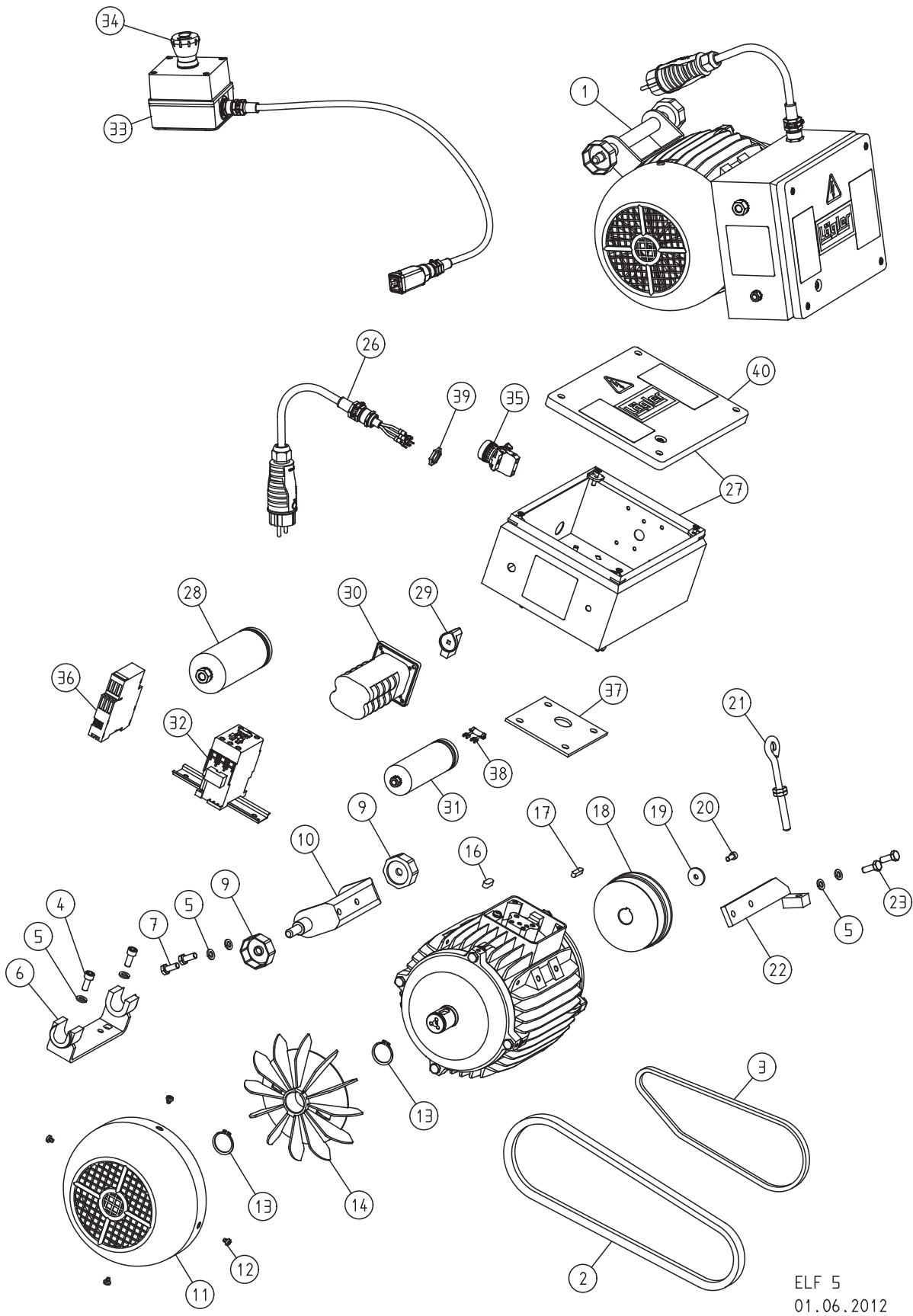

ELF 5
01.06.2012

SPARE PARTS ELF

Item	Part number	Description
1	100.65.00.100	Motor, 230 V / 50 CPS / 2.2 kW
	101.65.00.100	Motor, 230 V / 60 CPS / 2.2 kW
	102.65.00.100	Motor, 220 V / 60 CPS / 2.9 kW, USA
	105.65.00.100	Motor, 400 V / 50 CPS / 4.0 kW, three-phase current
2	000.70.17.092	V-belt
	000.71.26.090	V-belt 17 x 900 (ELF with HONDA motor)
3	000.70.10.067	V-belt
4	0912.1008.020	Screw
5	0127.1008.000	Spring washer
6	100.65.29.200	Motor bearing bracket
7	0933.1008.020	Screw
9	100.65.30.100	Motor nut
10	100.65.25.100	Motor mounting
11	100.65.09.100	Fan cover
12	7500.1005.006	Screw
13	0471.0030.000	Circlip
14	100.65.08.105	Fan wheel
16	6885.0807.020	Parallel key
17	6885.0606.025	Parallel key
18	100.65.06.100	Motor pulley
19	000.10.10.061	Washer
20	0912.1006.014	Screw
21	100.65.80.205	Eye bolt
22	100.65.35.100	Motor tensioner
23	0933.1008.022	Screw
26	100.65.75.100	Motor cable 3 x 2.5 mm ² (from year of manufacture 2008)
	000.65.43.251	Motor cable 3 x 2.5 mm ² (up to year of manufacture 2007)
	102.65.75.100	Motor cable 3 x 2.5 mm ² , USA (from year of manufacture 2008)
	000.65.43.257	Motor cable 3 x 2.5 mm ² , USA (up to year of manufacture 2007)
	105.65.75.100	Motor cable 5 x 1.5 mm ² for three-phase AC motor (from year of manufacture 2008)
	000.65.45.151	Motor cable 5 x 1.5 mm ² for three-phase AC motor (up to year of manufacture 2007)
27	100.65.40.200	Switch box for 230 V / 50 CPS
	102.65.40.200	Switch box for 220-230 V / 60 CPS + three-phase current
28	000.65.10.041	Running capacitor 40 µF
29	000.65.62.211	Switch button
30	000.65.60.253	Switch
	000.65.60.401	Switch for three-phase AC motor
31	000.65.10.061	Starting capacitor 60 µF
	000.65.10.131	Starting capacitor 130 µF, USA
32	000.65.20.035	Contacteur
	000.65.20.032	Contacteur complete for three-phase AC motor
33	102.65.60.200	Emergency switch USA, complete
34	000.65.62.221	Red button for emergency switch USA
35	000.65.25.020	Lamp red for three-phase AC motor
36	000.65.20.220	Relay for three-phase AC motor
37	100.65.14.105	Sealing plate
38	000.65.12.091	Discharging resistor
39	000.68.60.207	Nut (from year of manufacture 2008)
	000.68.60.163	Nut (up to year of manufacture 2007)
40	100.65.47.100	Cover with seal

SPARE PARTS ELF

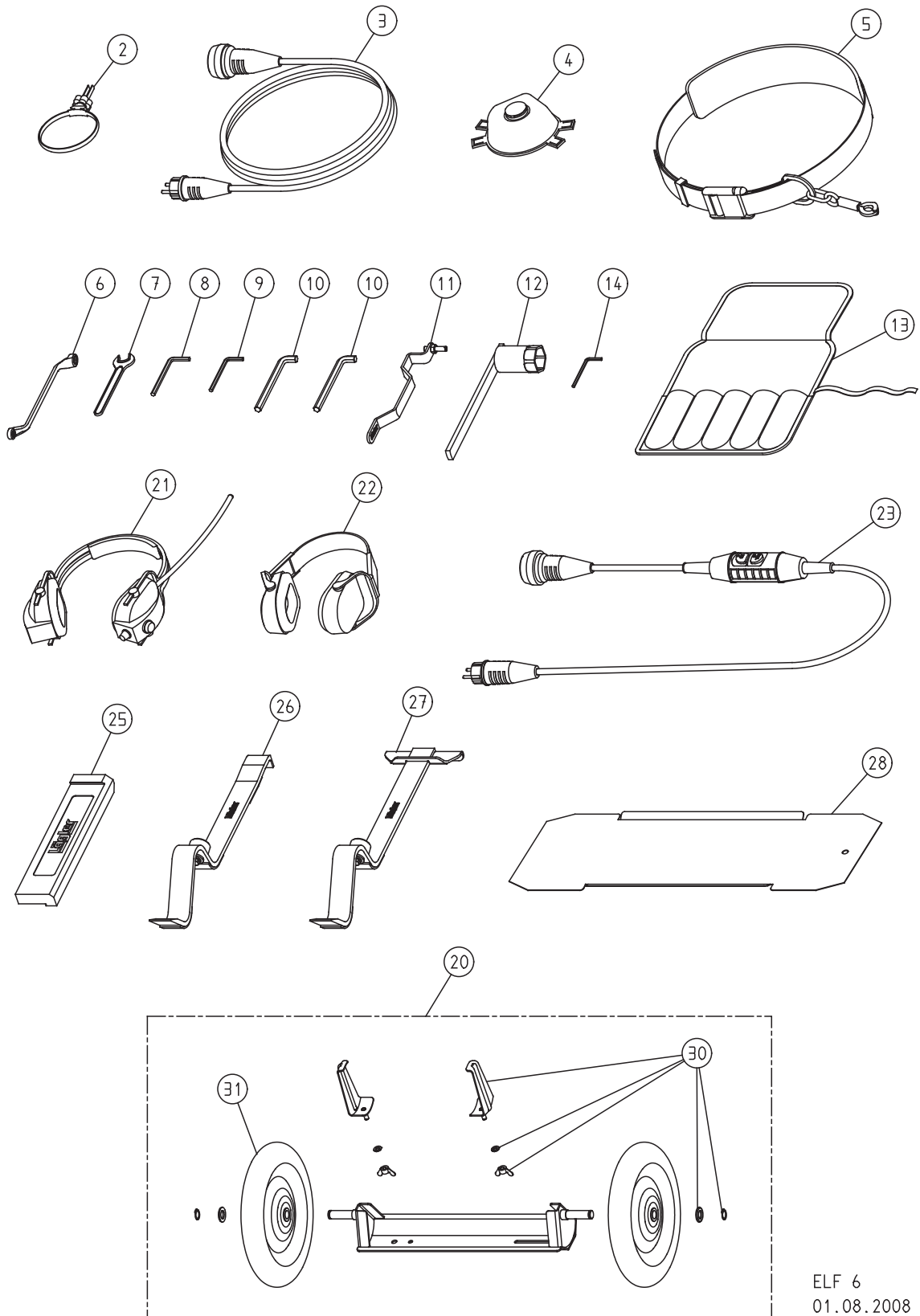

ELF 6
01.08.2008

SPARE PARTS ELF

Item	Part number	Description
2	000.01.40.110	MultiClip
3	000.65.53.251	Extension cable 3 x 2.5 mm ² , 10 m long
	000.65.53.252	Extension cable 3 x 2.5 mm ² , 20 m long
	000.65.55.151	Extension cable 5 x 1.5 mm ² , 10 m long, for three-phase AC motor
4	000.01.20.010	Respiratory protection mask P3
5	000.01.50.010	Safety belt
6	000.95.21.103	Closed mouth wrench 10/13 mm
7	000.95.11.171	Open mouth wrench 17 mm
8	000.93.11.061	Hexagonal socket screw wrench 6 mm
9	000.93.11.051	Hexagonal socket screw wrench 5 mm
10	000.93.11.101	Hexagonal socket screw wrench 10 mm
11	100.00.50.100	Setting fixture
12	100.00.45.105	Box wrench
13	000.01.30.011	Tool bag, empty
	200.98.00.100	Tool bag, complete
14	000.93.11.041	Hexagonal socket screw wrench 4 mm
20	720.00.00.200	Trolley TRANSCART, complete
21	000.01.10.011	Foldable earmuff type MUSIMUFF with FM radio
22	000.01.10.021	Foldable earmuff type POCKET
23	000.01.65.020	Safety switch PRCD-S (for German mains supply)
25	701.10.00.100	Impact tool
26	702.00.00.200	Parquet layer tool ZUGEISEN, small
27	703.00.00.200	Parquet layer tool ZUGEISEN, broad
28	200.00.40.105	Template ELF 200
	250.00.40.105	Template ELF 250
	300.00.40.105	Template ELF 300
30	720.10.00.200	Accessories TRANSCART
31	720.05.00.205	Wheel TRANSCART