



The Short **WM. MALCOLM**[®] Telescopic Sight Owner's Manual



WARNING:

It is absolutely necessary to securely mount the scope to your rifle. The front and rear scope mounts require installation using the 60° type dovetail bases provided or equivalent bases. This should be done by a competent gunsmith and will require drilling and tapping your barrel. Failure to follow this procedure can result in serious personal injury.

Contact Information:

Hi-Lux, Inc.

3135 Kashiwa Street

Torrance, CA 90505

Tel: (310) 257-8142, Fax: (310) 257-8096

E-mail: sales@hi-luxoptics.com

Website: <http://www.hi-luxoptics.com>

Technical Support: techsupport@hi-luxoptics.com

© 2016 Hi-Lux, Inc.; Leatherwood[®] & Malcolm[®] are the trademarks of Hi-Lux, Inc.

THANK YOU for purchasing the Wm. Malcolm short telescopic rifle scope manufactured by Leatherwood Hi-Lux Optics.

Since very little is generally known about early telescopic sights, a little history is in order to understand where the Wm. Malcolm short telescopic sight fits in.

Good terrestrial telescopes were being built by the early 1700's. These had all the optical quality that was necessary for a rifle telescope. However it would not be until the mid 1800s that rifles became sufficiently accurate to require a telescopic sight.

The problem was how to mount the scope to the rifle so that it could be zeroed to the rifle. In 1855, William Malcolm started building riflescopes. He understood that a riflescope must be properly constructed to hold zero. He made his scope tubes, by the same procedure as was used to build rifle barrels, by boring them from solid bar stock. The lenses were mounted on separate housings, securely screwed to the scope tube.

His first mounts followed the pattern that was written about by John Chapman in his book published in 1844 and used by many early riflescope builders. The elevation adjustment was a threaded post in the rifle tang.

At some point (probably after the Civil War), Malcolm devised a new solution to more precisely adjust elevation. He built a "rabbit ear" type mount that was located where the rear sight was usually positioned. This was much more rugged than the previous designs and could be precisely adjusted either by a vernier scale or a scale and a micrometer like screw system. Additionally, he assembled his scopes to withstand the recoil of the heavier calibers.

Between the opening of the West and the death of the great Buffalo herds, Malcolm scopes saw it all.

As repeating rifles appeared and the need for long-range single shot rifles was on the wane, short scopes in new styles of mounts began to appear. By the turn of the century, Malcolm was primarily producing this type of scope. Our new Malcolm 3X short scope is a design that continued in use even during WWII. By the turn of the 20th Century, Malcolm had become the leading scope manufacturer in the U.S. The

company continued in business until WWII, even though some new optical technologies, which would make these types of scopes obsolete, had been developed in Europe. However Americans would still carry this type of scope into combat during WWII. Descendents of these scopes such as the Unertl were used in combat as late as Vietnam.

Our Wm. Malcolm vintage scopes are constructed in the same manner as the original, sharing the authentic look and feel of the original scopes. While the aesthetics and mechanical performance of the Wm. Malcolm scopes are reminiscent of the original, the optical performance is much improved due to the fully multicoated HD lenses.

TABLE OF CONTENTS

Section 1.	Riflescope Specifications	page 4
Section 2.	Basic Definitions and Adjustments	page 4
Section 3.	Adjusting the Short Wm. Malcolm Telescopic Riflescope	page 5
Section 4.	Mounting the Short Wm Malcolm Riflescope On The Rifle	page 6
Section 5.	Sighting in the Short Wm. Malcolm Telescopic Riflescope	page 6
Section 6:	Removing the Short Wm. Malcolm Mounts	page 9
Section 7:	Micrometer Mount Set For the Short "Wm. Malcolm" Telescopic Riflescope (SKU: MUSMCMT)	page 9
Section 8:	DiamondTuff Guarantee	page 11

Section 1: Riflescope Specifications

Model	Power	Obj. (mm)	F.O.V.@ 100 Yds (Feet)	Eye Relief (Inch)	Length (Inch)	Weight (O.Z.)	Exit Pupil Range (mm)	Tube Size
M334151	3X	17	15	4.5	17	17.5	5.8	¾"
M634181	6X	17	12	4.5	18	18	5.8	¾"

All the air-glass surfaces are fully multi-coated with our proprietary DiamondTuff14 to maximize light transmission. The Parallax adjusts from 10' to infinity. The reticle is a fine crosshair. The rear mount is a Caged Type Mount with windage and elevation adjustment built in. The main tube is ¾" in diameter. The scope is a shockproof, waterproof and nitrogen purged at the factory.

Section 2: Basic Definitions and Adjustments

A. Eyepiece:

The eyepiece is at the rear end of the scope. A knurled locking ring secures the eyepiece. You can change the scope's focus to suit your individual eyesight. Loosen (turn clockwise) the knurled locking ring, and turn the eyepiece clockwise or counter-clockwise until you are comfortable with the focus. Then, tighten the locking ring snugly. Tighten the locking ring finger tight only. Do not use tools to tighten.

B. Rear Mount.



The windage and elevation adjustments are located on the Rear Mount. It has a standard 60-degree type dovetail groove and a locking screw.

C. Front Mount.

The front mount provides a precise pivot system for the scope. It has the standard 60-degree dovetail groove and locking screw. There is also a locking ring attached with the front mount to

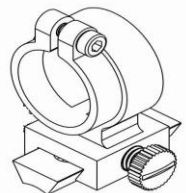

prevent the scope tube from rotating and moving forward.

D. Standard 60° type dovetail base

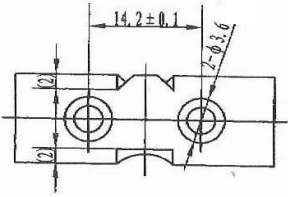

The scope comes with two pieces standard 60-degree type dovetail bases. The dovetail slots in the mount are cut 1/2" wide. The cross section dimensions should be compatible with

the popular bases that have been used in the market for 100 years. The hole spacing is 14.2mm from center to center. Unertl bases or other 60-degree bases should work with the provided scope mounts. The dovetail slot in the mounts is 1/2 inch wide.

Section 3: Adjusting the Short "Wm. Malcolm" Telescopic Rifle Scope

The Wm. Malcolm short scope is designed to replicate the look of the scopes that were popular during the Civil War era and continued in use until WWII. However, we have built the Malcolm scopes using best practices in optical manufacturing from fully multi-coating glass lenses to nitrogen purging, to give the modern shooter a fun and dependable scope.

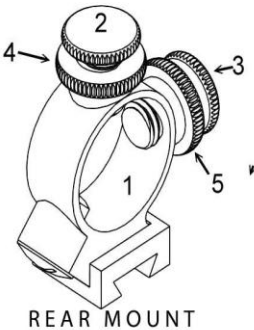

REAR MOUNT

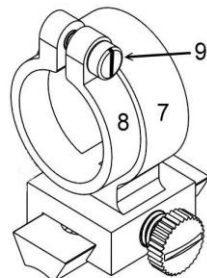

FRONT MOUNT

Don't let the external adjustments of the Short Wm. Malcolm mounts intimidate you. It will only take a few minutes to

understand the relationship between the front and rear mounts. You'll find that making sight adjustments with the rear mount is actually every bit as easy as making sight adjustments with the standard equipment open sights that probably came installed on your rifle. In fact, the movements of all adjustments with these mounts have the same exact effect on the point of impact as the same adjustments made with standard open sights.

The **REAR MOUNT** offers adjustments for both **WINDAGE** and **ELEVATION**. When the **SIDE TURRET** is turned **COUNTER-CLOCKWISE**, the point of impact moves to the **RIGHT**. When the **SIDE TURRET** is turned **CLOCKWISE**, the point of impact moves **LEFT**.

When the **TOP TURRET** is turned **COUNTER CLOCKWISE**, the point of impact moves **UPWARD**. When the **TOP TURRET** is turned **CLOCKWISE**, the point of impact moves **DOWNWARD**.

Section 4: Mounting the Short Wm Malcolm Telescopic Rifle Scope

The front and rear mounts are designed to fit the standard 60-degree type base, which has been used for over 100 years to mount externally adjusted scopes. The dovetail slots in the mounts are cut ½" wide. This type of base has been widely used for many externally adjusted scopes such as the Unertl and Fecker. Our clamp screw is designed to engage either the half moon slot or the 'Posa cut' slot found on these bases. The supplied bases have both types of slots, one on each side. If the scope is going to be used on a high recoil rifle, the base locking screw should engage a 'Posa cut' slot to prevent scope movement from recoil.

Section 5: Steps to Sight in the Short Wm. Malcolm Telescopic Rifle Scope

1. Make sure that the mounts have been correctly and securely attached to the barrel using the mounting

blocks provided (will require gunsmithing if rifle is not pre-drilled and tapped), and that the crosshairs in the scope are level. This can be done by loosening the **SCREW (9)** at the top of the **STOP RING (8)** used in conjunction with the **FRONT MOUNT (7)**. This allows the scope tube to be rotated until the crosshairs are level. Be sure to retighten the screw to prevent the scope tube from sliding forward and turning in the mount.

2. Familiarize yourself with all of the features of the scope and mounts, especially the **LOCK COLLAR (4 & 5)** of both the **SIDE TURRET SCREW (1)** and **TOP TURRET SCREW (1)**. Before adjustment can be made with either turret, the **LOCK COLLAR** must be loosened by turning **COUNTER CLOCKWISE**.
3. We recommend zeroing at just 25 yards, placing a sizeable 2'x2' or large sheet of cardboard or paper on the target board. Using a small aiming mark near the middle of the target, center the crosshairs and take a shot. If you're on the paper, you have your starting point.
4. It's best to adjust the windage first. Begin by first loosening the **LOCK COLLAR (5)**, then adjust the **SIDE TURRET SCREW (3)** to move the scope tube in the direction you want to move the point of impact. To move shots to the **RIGHT**, turn the adjustment knob **COUNTER CLOCKWISE**. To move shots to the **LEFT**, turn the adjustment knob **CLOCKWISE**.

Note: Like the original scopes of this design, there are no micrometer clicks. However, there are numbered graduations, so pay attention to how much you moved the adjustment knob, and how far the point of impact moved. This will make additional adjustments easier.

5. Once windage has been adjusted, retighten the **LOCK COLLAR (4)** by turning it **CLOCKWISE**.
6. To adjust elevation, first loosen the **LOCK COLLAR (4)** of **TOP TURRET SCREW (2)** by turning the **LOCK COLLAR COUNTER CLOCKWISE**. To move point of impact **UP**, turn the adjustment knob **COUNTER CLOCKWISE**. To move point of impact **DOWN**, turn adjustment knob **CLOCKWISE**.
7. Once elevation has been adjusted, retighten the **LOCK COLLAR (4)** by turning it **CLOCKWISE**.
8. Move target to 50 yards and repeat this process. Once the rifle is on paper, move the target to 100 yards and repeat again to secure a good 100 yd zero.

Note on Zeroing Certain Rifle Calibers:

The caged rear mount of the Short Wm. Malcolm Scope (circa 1890) does not provide as much elevation for low velocity big bore black powder cartridge rifles (i.e. .45-70, .50-70, .50-90) as the rear mount of the earlier styled Long Wm. Malcolm scope (circa 1870). However, it should provide ample adjustment for typical hunting ranges (100 to 200 yards) with the large .45 and .50 caliber metallic cartridge rifles, while providing adjustment for 250 to 300 yard shooting with rifles chambered for the faster and lighter bullets of cartridges like the .30-40 Krag, .30-30 Winchester or .30-06 Springfield.

We also manufacture special mounts available to mount the short scopes for Win. 1885, Win. 73/76, Win. 92/94, Marlin 94/95, Henry Golden Boy .22, and the Sharps Side Mount Set. For more details, please contact Hi-Lux customer support at (888) Hi-Lux12 (888-445-8912).

Section 6: Removing the Wm. Malcolm Short Scope Mounts

Instructions to Remove the Existing Mounts

1. Remove the eyepiece and the lock ring. The scope is sealed and the nitrogen will not escape.
2. Turn the windage and elevation turrets clockwise, until the turret stops. Doing so, will relieve some of the spring pressure of the mount on the tube.
3. Remove the rear mount slowly to reduce the likelihood of scratches on the scope body.
4. Loosen the front sliding lock ring.
5. Remove the front mount slowly from the back (Eyepiece side).

WARNING: We highly recommend that you lubricate the Malcolm scope body with Multi-Purpose Oil prior to removing the mounts. Doing so will mitigate friction from the mount sliding across the scope body.

Section 7: Micrometer Mount Set for the Short Wm. Malcolm Telescopic Rifle Scope (Item: MUSMCMT)

MUSMCMT INSTALLATION INSTRUCTIONS

1. You need to install the front mount and the sliding lock ring together on the scope tube and move them to position on the right. Then put the slotted plunger in the front mount housing. You may need to hand-fit the plunger to make sure that it slides on the rail smoothly. Insert the

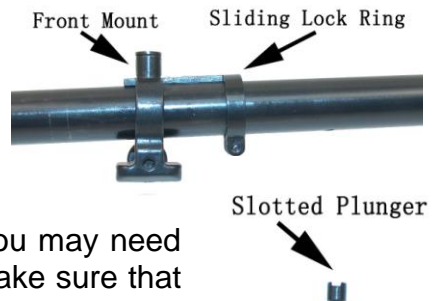

spring and tighten the cap screw slowly. Meanwhile, you need to check to see if the front mount can be moved back and forth smoothly. Make sure the reticle is straight and tighten the sliding lock ring screw to prevent the front mount from moving.

2. Insert the two “F” plates into the windage and elevation turrets. Push the “F” plates all the way into the center of the turrets. Then put the rear mount on the scope tube and the windage knob is on the right. Then you can insert the plunger and the spring and tighten the cap screw.



3. Make sure that the spacing between the centers of the front and rear mounts is 7.2 inches. This will give you a $\frac{1}{4}$ MOA per click adjustment.



4. There are two $\frac{1}{2}$ " wide 60° type bases included. You may need to modify the bases to fit the mount. The ‘Posa’ cut side of the base will be used to engage with the mount.

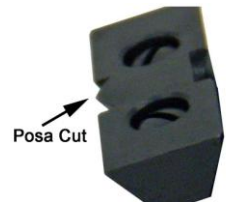

If you have any questions about this mounting set or installation, please feel free to contact us at +1 (888) HI-LUX-12 (445-8912) or send us an e-mail at customerservice@hi-luxoptics.com.

Section 8: DiamondTuff Guarantee

Hi-Lux, Inc. warrants its products against defects arising from faulty workmanship, or materials, for the lifetime of the product. **Normal wear and tear is not covered by this limited lifetime warranty.** Any attempt to alter, dismantle or change the standard specifications of the products, will make this warranty null and void. This warranty is made to the **original purchaser** of the goods including all international sales, and applies only to the products purchased through our authorized distributors or dealers. The international warranty is subject to approval from our authorized distributor or us directly. Warranty obligation is limited to the repair or replacement of any product returned to **Hi-Lux, Inc.**, which is determined by the manufacturer to have defects arising from faulty workmanship, or materials that adversely affect the satisfactory operation of the product. It should be noted that on items containing an etched glass reticle that the occasional appearance of some small particles is common and not a warrantable repair. **There is a two-year warranty from the date of purchase for the electronic components that are contained on or within the products.** **Hi-Lux, Inc.** reserves the right to request proof of purchase and purchase date. To guarantee warranty service, the enclosed warranty form must be completed and returned or register online at www.hi-luxoptics.com within 90 days of purchase to establish all warranty rights between you, the original purchaser, and **Hi-Lux, Inc.** We assume no liability for any incidental or consequential damages, or incidental expenses. Some states do not allow the exclusion or limitation of incidental or consequential damages, so the above limitations or exclusion may not apply to you. No warranties are made, or are authorized to be made, other than those expressly contained herein. To file a claim under this warranty, please contact the Customer Service Department of **Hi-Lux, Inc.** at (310) 257-8142 to obtain a Return Authorization number (RA number). After receiving your RA

number, please mark the number on the outside of the package; enclose the defective item with a brief explanation of the problem. Please be sure to include your name, address and phone number. Failure to obtain a RA number may result in either refusal upon delivery, or lengthy delays for warranty repairs and service required for the item returned to us. All returns are to be shipped prepaid direct to **Hi-Lux, Inc.** including a check or money order in the amount of \$21 to cover postage and handling regardless of purchase date.

Attn.: Warranty & Service Dept.

Hi-Lux, Inc.

3135 Kashiwa Street

Torrance, CA 90505

Tel: (310) 257-8142, Fax: (310) 257-8096

E-Mail: service@hi-luxoptics.com

Website: www.hi-luxoptics.com

In the event of a non-warranty repair, you will receive an estimate prior to any work being done. This warranty gives you specific legal rights and you may have other rights, which vary from state to state. As defined by federal law, this is a limited warranty.



Leatherwood

We Lead the Way™