

# STILETTO ™



Blizzard Lighting, LLC  
[www.blizzardlighting.com](http://www.blizzardlighting.com)  
Waukesha, WI USA  
Copyright (c) 2016

# TABLE OF CONTENTS

Stiletto™ I7 Moving Head	1
<b>1. Getting Started</b>	<b>3</b>
What's In The Box?	3
Getting It Out Of The Box	3
Powering Up!	3
Getting A Hold Of Us	3
Safety Instructions (Don't Stick Your Hand In The Toaster!)	4
<b>2. Meet The Stiletto™ I7 Moving Head</b>	<b>5</b>
Features	5
DMX Quick Reference	5
The Stiletto™ I7 Pin-up Picture	6
<b>3. Setup</b>	<b>7</b>
Fuse Replacement	7
Connecting A Bunch Of Stiletto™ I7 Fixtures	7
Data/DMX Cables	7
Cable Connectors	8
3-Pin??? 5-Pin??? Huh?	8
Take It To The Next Level: Setting up DMX Control	8
Fixture Linking (Master/Slave Mode)	9
Mounting/Rigging	9
Mounting Points	10
Clamp Mounting	11
Securing the fixture	11
<b>4. Operating Adjustments</b>	<b>12</b>
The Control Panel	12
Control Panel Menu Structure	13
DMX Mode	14
Set The Starting DMX Address	14
Select the DMX Channel Mode	14
Select the DMX Run Mode	14
Auto, Sound Active, & Manual Adjustments	14
Auto Mode	14
Sound Active Mode	14
Loss of DMX Setting	14
Invert Pan/Tilt, Auto Position Correction	14
Dimming Curves	14
Reset Functions	14
DMX Values In-Depth	15
Troubleshooting	17
<b>5. Appendix</b>	<b>18</b>
A Quick Lesson On DMX	18
Keeping Your Stiletto™ I7 As Good As New	19
Returns (Gasp!)	19
Shipping Issues	19
Tech Specs	20
Dimensional Drawings	21

# 1. GETTING STARTED

## What's In The Box?

- 1 x Stiletto™ I7 Moving Head
- 1 x Really Classy DMX Cable
- 1 x Sweet Safety Cable
- 1 x Set of Mounting Brackets
- An Ever-So-Handy Power Cord
- This Lovely User Manual

## Getting It Out Of The Box

Congratulations on your purchase of the amazing Stiletto™ I7, your new lighting eye of the storm! Now that you've got your Stiletto™ I7 (*or hopefully, I7s!*), you should carefully unpack the box and check the contents to ensure that all parts are present and in good condition. If anything looks as if it has been damaged in transit, notify the shipper immediately and keep the packing material for inspection. Again, please save the carton and all packing materials. If a fixture must be returned to the factory, it is important that the fixture be returned in the original factory box and packing.

## Powering Up!

All fixtures must be powered directly off a switched circuit and **cannot be run off a rheostat (variable resistor) or dimmer circuit, even if the rheostat or dimmer channel is used solely for a 0% to 100% switch.**

*AC Voltage Switch* - Not all fixtures have a voltage select switch, so please verify that the fixture you receive is suitable for your local power supply. See the label on the fixture or refer to the fixture's specifications chart for more information. A fixture's listed current rating is its average current draw under normal conditions. Check the fixture or device carefully to make sure that if a voltage selection switch exists that it is set to the correct line voltage you will use.

**Warning! Verify that the voltage select switch on your unit matches the line voltage applied. Damage to your fixture may result if the line voltage applied does not match the voltage indicated on the voltage selector switch. All fixtures must be connected to circuits with a suitable Ground (Earthing).**

## Getting A Hold Of Us

**If something is wrong, please just visit our website at [www.blizzardlighting.com/support](http://www.blizzardlighting.com/support) and open a support ticket. We'll be happy to help, honest.**

**Disclaimer:** The information and specifications contained in this document are subject to change without notice. Blizzard Lighting™ assumes no responsibility or liability for any errors or omissions that may appear in this user manual. Blizzard Lighting™ reserves the right to update the existing document or to create a new document to correct any errors or omissions at any time. You can download the latest version of this document from [www.blizzardlighting.com](http://www.blizzardlighting.com).

Author:	Date:	Last Edited:	Date:
J.Thomas	9/6/2016	J.Thomas	11/17/2016

# SAFETY INSTRUCTIONS



Please read these instructions carefully. They include important information about the installation, usage and maintenance of this product.

- Please keep this User Guide for future use. If you sell the unit to someone else, be sure that they also receive this User Guide.
- ALWAYS make sure that you are connecting to the proper voltage, and that the line voltage you are connecting to is not higher than that stated on the decal or rear panel of the fixture.
- This product is intended for indoor use only.
- To prevent risk of fire or shock, do not expose fixture to rain or moisture.
- Make sure there are no flammable materials close to the unit while operating.
- The unit must be installed in a location with adequate ventilation, at least 20in (50cm) from adjacent surfaces. Be sure that no ventilation slots are blocked.
- ALWAYS disconnect from the power source before servicing or replacing fuse and be sure to replace with same fuse size and type.
- ALWAYS secure fixture using a safety chain. NEVER carry the fixture by its cord. Use its carrying handles.
- DO NOT operate at ambient temperatures higher than 104°F (40°C).
- In the event of a serious operating problem, stop using the unit immediately. NEVER try to repair the unit by yourself. Repairs carried out by unskilled people can lead to damage or malfunction. Please contact the nearest authorized technical assistance center. Always use the same type spare parts.
- NEVER connect the device to a dimmer pack.
- Make sure the power cord is never crimped or damaged.
- Never disconnect the power cord by pulling or tugging on the cord.
- Avoid direct eye exposure to the light source while it is on.

**Caution!** There are no user serviceable parts inside the unit. Do not open the housing or attempt any repairs yourself. In the unlikely event your unit may require service, please contact Blizzard Lighting at [www.blizzardlighting.com/tickets](http://www.blizzardlighting.com/tickets).

## 2. MEET THE STILETTO™ I7 MOVING HEAD

### MAIN FEATURES

- 7\* 15W ultra-bright OSRAM® 4-in-1 RGBW LEDs
- Pan: 540°/ Tilt: 270° (8-16 Bit Resolution)
- Variable 4-60° beam angle
- Moving beam, wash, or kaleido effects
- Infinite bidirectional rotating lens
- Built-in auto and sound active programs
- Ultra-smooth 32-bit dimming
- Internal fan cooling system
- PowerCON® compatible power in/out connectors
- Compact, high quality housing

### CONTROL:

- USITT DMX-512, 27/55-channel DMX modes
- Standalone, master/slave, & sound active modes
- 3-pin DMX input and output
- Easy-to-use, 5-button LCD control panel

### DMX Quick Reference (27/55-Channel Modes)

27Ch	55Ch	What it does	27Ch	55Ch	What it does
1	1	Pan	--	29	Led 1 Green
2	2	Fine Pan	--	30	Led 1 Blue
3	3	Tilt	--	31	Led 1 White
4	4	Fine Tilt	--	32	Led 2 Red
5	5	Dimmer	--	33	Led 2 Green
6	6	Strobe	--	34	Led 2 Blue
7	7	Red	--	35	Led 2 White
8	8	Green	--	36	Led 3 Red
9	9	Blue	--	37	Led 3 Green
10	10	White	--	38	Led 3 Blue
11	11	Linear CTO	--	39	Led 3 White
12	12	Marco Color	--	40	Led 4 Red
13	13	Function	--	41	Led 4 Green
14	14	Zoom	--	42	Led 4 Blue
15	15	Lens Rotation	--	43	Led 4 White
16	16	Shape Choice	--	44	Led 5 Red
17	17	Shape Speed	--	45	Led 5 Green
18	18	Shape Delay	--	46	Led 5 Blue
19	19	Shape Red	--	47	Led 5 White
20	20	Shape Green	--	48	Led 6 Red
21	21	Shape Blue	--	49	Led 6 Green
22	22	Shape White	--	50	Led 6 Blue
23	23	Foreground Dimmer	--	51	Led 6 White
24	24	Background Dimmer	--	52	Led 7 Red
25	25	Shape Change	--	53	Led 7 Green
26	26	Shape Offset	--	54	Led 7 Blue
27	27	Reset	--	55	Led 7 White
--	28	Led 1 Red	--	--	--

**Figure 1: The Stiletto™ I7 Pin-Up Picture**



**Figure 2: The Rear Connections**

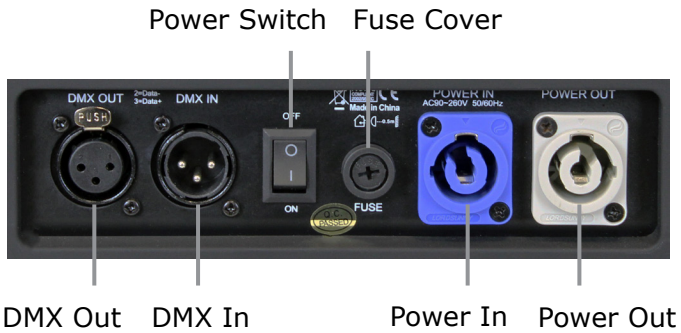

### 3. SETUP



Before replacing a fuse, disconnect power cord. ALWAYS replace with the same type and rating of fuse.

#### Fuse Replacement

With a philips head screwdriver, unscrew the fuse holder out of its housing. Remove the damaged fuse from its holder and replace with exact same type of fuse. Reattach the fuse holder, and then reconnect power.

#### Connecting A Bunch of Stiletto™ I7 Fixtures

You will need a serial data link to run light shows using a DMX-512 controller or to run shows on two or more fixtures set to sync in master/slave operating mode. The combined number of channels required by all the fixtures on a serial data link determines the number of fixtures the data link can support.

Fixtures on a serial data link must be daisy chained in one single line. Also, connecting more than 32 fixtures on one serial data link without the use of a DMX optically-isolated splitter may result in deterioration of the digital DMX signal. The maximum recommended cable-run distance is 500 meters (1640 ft). The maximum recommended number of fixtures on a serial data link is 32 fixtures.

#### Data/DMX Cabling

To link fixtures together you'll need data cables. You should use data-grade cables that can carry a high quality signal and are less prone to electromagnetic interference.

For instance, Belden© 9841 meets the specifications for EIA RS-485 applications. Standard microphone cables will "probably" be OK, but note that they cannot transmit DMX data as reliably over long distances. In any event, the cable should have the following characteristics:

*2-conductor twisted pair plus a shield  
Maximum capacitance between conductors – 30 pF/ft.  
Maximum capacitance between conductor & shield – 55 pF/ft.  
Maximum resistance of 20 ohms / 1000 ft.  
Nominal impedance 100 – 140 ohms*

## Cable Connectors

Cables must have a male XLR connector on one end and a female XLR connector on the other end. (Duh!)

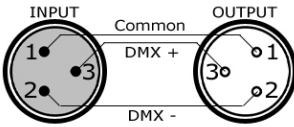

**A Word on Termination:** DMX is a resilient communication protocol, however errors still occasionally occur. Termination reduces signal errors, and therefore best practices include use of a terminator in all circumstances. If you are experiencing problems with erratic fixture behavior, especially over long signal cable runs, a terminator may help improve performance.

**To build your own DMX Terminator:**  
Obtain a 120-ohm, 1/4-watt resistor, and wire it between pins 2 & 3 of the last fixture. They are also readily available from specialty retailers.

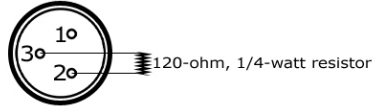

**CAUTION:** Do not allow contact between the common and the fixture's chassis ground. Grounding the common can cause a ground loop, and your fixture may perform erratically. Test cables with an ohm meter to verify correct polarity and to make sure the pins are not grounded or shorted to the shield or each other.

## 3-Pin??? 5-Pin??? Huh?!?

If you use a controller with a 5 pin DMX output connector, you will need to use a 5 pin to 3 pin adapter. They are widely available over the internet and from specialty retailers. If you'd like to build your own, the chart below details a proper cable conversion:

Conductor	3-Pin Female (Output)	5-Pin Male (Input)
Ground/Shield	Pin 1	Pin 1
DMX Data (-)	Pin 2	Pin 2
DMX Data (+)	Pin 3	Pin 3
Not Used.	No Connection.	No Connection.
Not Used.	No Connection.	No Connection.

## Take It To The Next Level: Setting Up DMX Control

**Step 1:** Connect the male connector of the DMX cable to the female connector (output) on the controller.



**Step 2:** Connect the female connector of the DMX cable to the first fixture's male connector (input). *Note:* It doesn't matter which fixture address is the first one connected. We recommend connecting the fixtures in terms of their proximity to the controller, rather than connecting the lowest fixture number first, and so on.

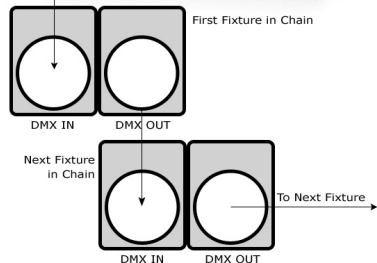

**Step 3:** Connect other fixtures in the chain from output to input as above. Place a DMX terminator on the output of the final fixture to ensure best communication.



## Fixture Linking (Master/Slave Mode)

1. Connect the (male) 3 pin connector side of the DMX cable to the output (female) 3 pin connector of the first fixture.
2. Connect the end of the cable coming from the first fixture which will have a (female) 3 pin connector to the input connector of the next fixture consisting of a (male) 3 pin connector. Then, proceed to connect from the output as stated above to the input of the following fixture and so on.

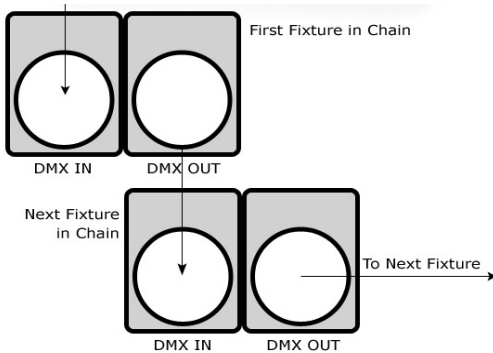

**A quick note:** Often, the setup for Master-Slave and Standalone operation requires that the first fixture in the chain be initialized for this purpose via either settings in the control panel or DIP-switches. Secondly, the fixtures that follow may also require a slave setting.

Check the **"Operating Adjustments"** section in this manual for complete instructions for this type of setup and configuration.

## Mounting & Rigging

This fixture may be mounted in any SAFE position provided there is enough room for ventilation.

It is important never to obstruct the fan or vents pathway. Mount the fixture using a suitable "C" or "O" type clamp. The clamp should be rated to hold at least 10x the fixture's weight to ensure structural stability. Do not mount to surfaces with unknown strength, and ensure properly "rated" rigging is used when mounting fixtures overhead.

Adjust the angle of the fixture by loosening both knobs and tilting the fixture. After finding the desired position, retighten both knobs.

- When selecting installation location, take into consideration lamp replacement access (if applicable) and routine maintenance.
- Safety cables **MUST ALWAYS** be used.
- Never mount in places where the fixture will be exposed to rain, high humidity, extreme temperature changes or restricted ventilation.

## Mounting Points

Overhead mounting requires extensive experience, which includes calculating working load limits, knowledge of the installation material being used, and periodic safety inspection of all installation material and the fixture. If you lack these qualifications, do not attempt the installation yourself. Improper installation can result in bodily injury.

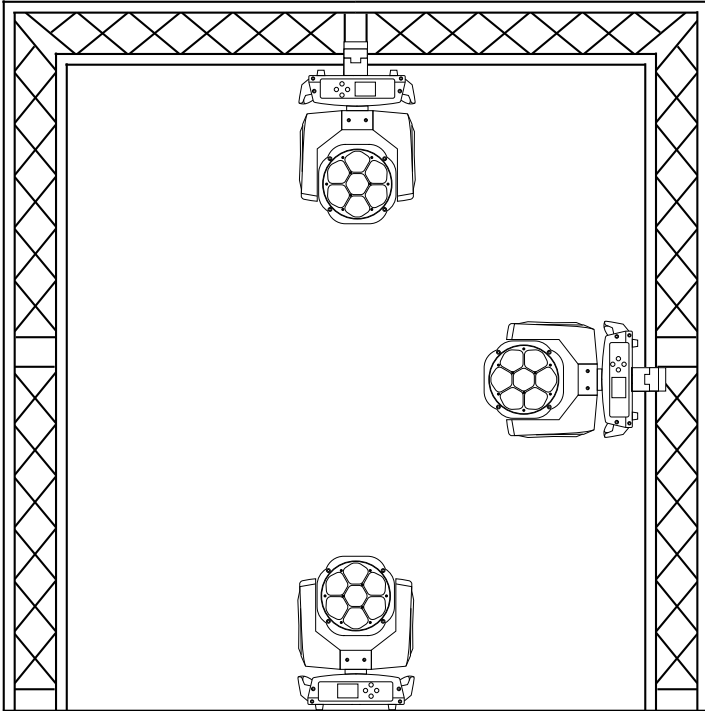

## Caution!

Please be aware, you should have a qualified electrician performing all of your electrical connection needs. Better safe than sorry!

Be sure to complete all rigging and installation procedures before connecting the main power cord to the appropriate wall outlet.

## Clamp Mounting

This fixture provides a mounting bracket assembly that secures the bottom of the base, the "Omega Brackets," and the safety cable rigging point together. When mounting this fixture to truss, be sure to secure an appropriately rated clamp to the omega bracket using an M10 screw fitted through the center hole of the "omega bracket".

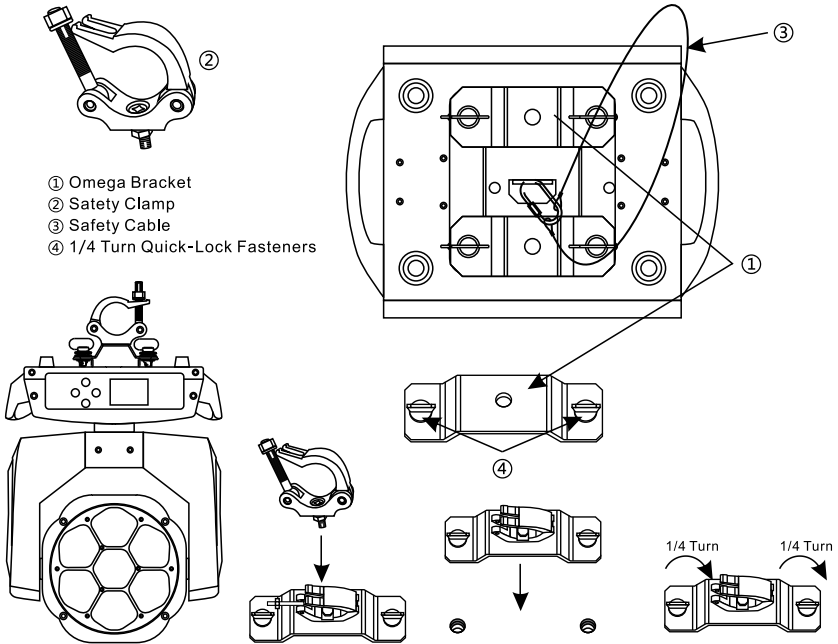

## Securing the Fixture

Regardless of the rigging option you choose for your fixtures always be sure to secure your fixture with a safety cable. Be sure to only use the designated rigging point found on the underside of the base assembly for the safety cable.

## 4. OPERATING ADJUSTMENTS

### The Control Panel

All the goodies and different modes possible with the Stiletto I7™ are accessed by using the control panel on the front of the fixture. There are 5 control buttons next to the LCD display which allow you to navigate through the various control panel menus.

#### <RIGHT>

Is used to navigate to a higher-level menu item.

#### <UP>

Scrolls through menu items and numbers in ascending order.

#### <DOWN>

Scrolls through menu items and numbers in descending order.

#### <OK>

Is used to save any changes made to a menu setting.

#### <LEFT>

To return to the previous option or menu without changing the value.

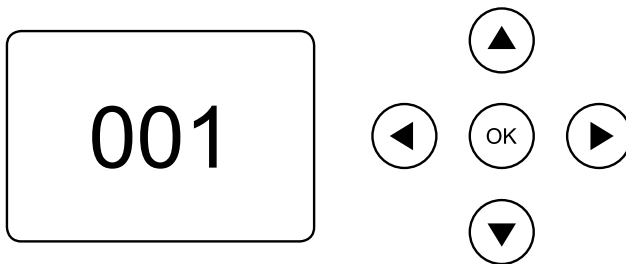

The control panel LCD display shows the menu items you select from the menu map on page #13. When a menu function is selected, the display will show immediately the first available option for the selected menu function. To select a menu item, press **<OK>**.

Use the **<UP>**, **<DOWN>**, and **<RIGHT>** buttons to navigate the menu options. Press the **<OK>** button to enable a menu option. To return to the previous option or menu without changing the value, press the **<LEFT>** button.

# Control Panel Menu Structure

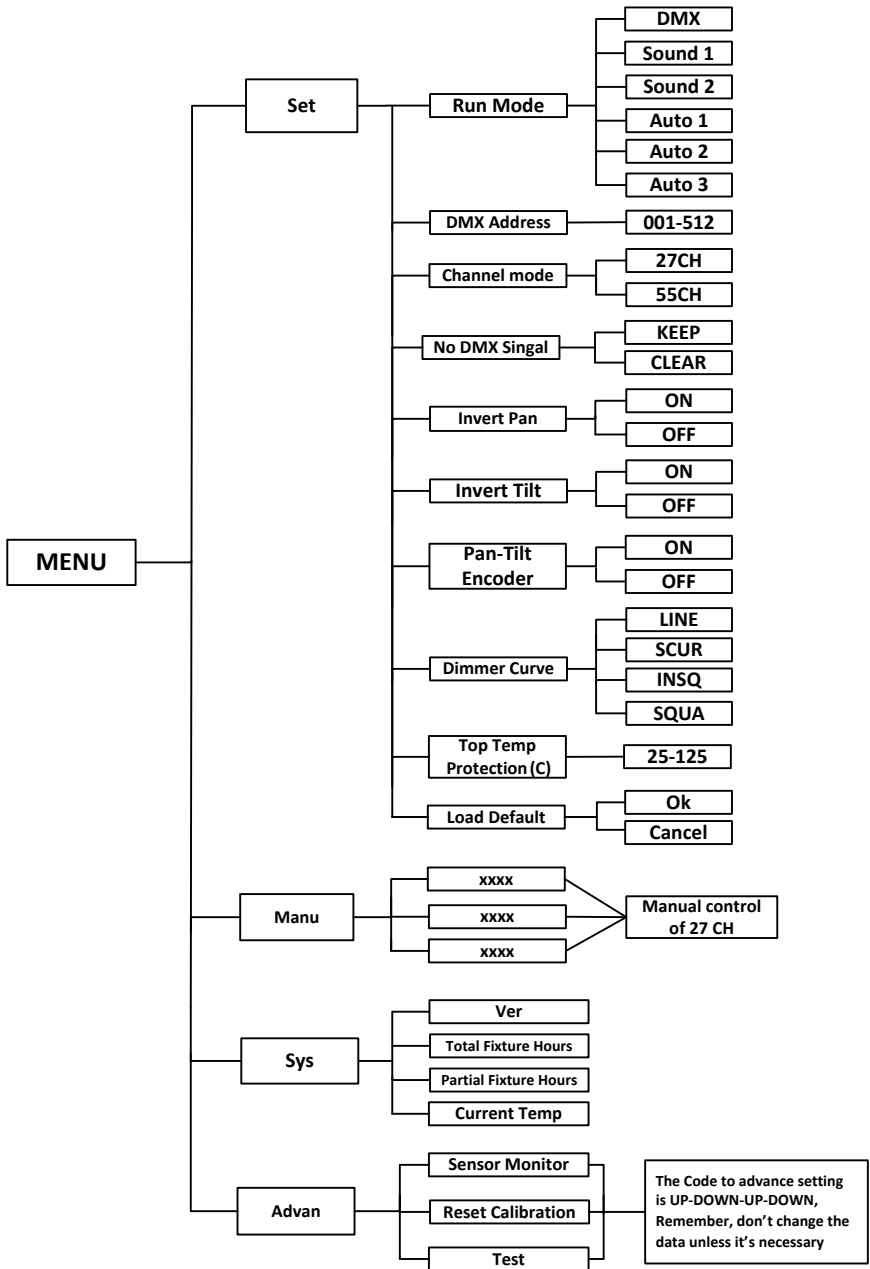

## DMX Mode

*Allows the unit to be controlled by any universal DMX controller.*

### Set the Starting DMX Address:

- 1.) Navigate the main menu until you reach **Set**.
- 2.) Push the **<OK>** button, then navigate to **DMX Address** and press **<OK>**.
- 3.) Use the **<UP/DOWN>** buttons to select a DMX channel from **001-512**.
- 4.) Press the **<OK>** button to confirm.

### Select the DMX Channel Mode:

- 1.) Navigate the main menu until you reach **Set**.
- 2.) Push the **<OK>** button, then navigate to **Channel Mode** and press **<OK>**.
- 3.) Use the **<UP/DOWN>** buttons to select either **27CH** or **55CH**.
- 4.) Press the **<OK>** button to confirm.

### Select the DMX Run Mode:

- 1.) Navigate the main menu until you reach **Set**.
- 2.) Push the **<OK>** button, then navigate to **Run Mode** and press **<OK>**.
- 3.) Use the **<UP/DOWN>** buttons to select **DMX**.
- 4.) Press the **<OK>** button to confirm your selection of DMX mode.

## Auto, Sound Active, & Manual Adjustments:

*Allows a single or Master/Slaved units to run factory installed programs at user selectable speeds.*

### Auto Mode:

- 1.) Navigate the main menu until you reach **Set**.
- 2.) Push the **<OK>** button, then navigate to **Run Mode** and press **<OK>**.
- 3.) Use the **<UP/DOWN>** buttons to select **Auto 1, Auto 2, or Auto 3**.
- 4.) Press the **<OK>** button to confirm your selection of auto mode.

### Sound Active Mode:

- 1.) Navigate the main menu until you reach **Set**.
- 2.) Push the **<OK>** button, then navigate to **Run Mode** and press **<OK>**.
- 3.) Use the **<UP/DOWN>** buttons to select **Sound 1, or Sound 2**.
- 4.) Press the **<OK>** button to confirm your selection of sound active mode.

### Loss of DMX Setting:

*If the DMX signal is lost, fixture will revert to this setting.*

- 1.) Navigate the main menu until you reach **Set**.
- 2.) Push the **<OK>** button, then navigate to **No DMX Signal** and press **<OK>**.
- 3.) Use the **<UP/DOWN>** buttons to select **Keep** (hold), or **Clear** (blackout).
- 4.) Press the **<OK>** button to confirm your selection.

### Invert Pan/Tilt, Auto Position Correction

- 1.) Navigate the main menu until you reach **Set**.
- 2.) Push **<OK>**, then navigate to **Invert Pan** or **Invert Tilt** and press **<OK>**.
- 3.) Use the **<UP/DOWN>** buttons to select **On or Off**.
- 4.) Press the **<OK>** button to confirm your selection.
- 5.) In the same manner, you can turn On/Off **Pan-Tilt Encoder** (Pan/Tilt position correction.)

### Dimming Curves

- 1.) Navigate the main menu until you reach **Set**.
- 2.) Push **<OK>**, then navigate to **Dimmer Curve** and press **<OK>**.
- 3.) From here, you can select **LINE** (linear), **SCUR** (s-curve), **INSQ** (inverse square law curve), or **SQUA** (square law curve).
- 4.) Press the **<OK>** button to confirm your selection.

### Reset Functions

- 1.) Navigate the main menu until you reach **Set**.
- 2.) Push **<OK>**, then navigate to **Load Default** and press **<OK>**.

## DMX Values In-Depth (27-Channel Mode)

Ch.	Value	What It Does
1	000 <--> 255	Pan
3	000 <--> 255	Fine Pan
2	000 <--> 255	Tilt
4	000 <--> 255	Fine Tilt
5	000 <--> 255	Dimmer (0% <--> 100%)
6	000 <--> 003	<b>Strobe</b> LED off, Strobe off
	004 <--> 019	LED on, Strobe off
	020 <--> 119	LED on, Strobe (slow <--> fast)
	120 <--> 129	LED on, Strobe off
	130 <--> 245	Pulse strobe (slow <--> fast)
	246 <--> 255	LED on, Strobe off
7	000 <--> 255	Red Intensity (0% <--> 100%)
8	000 <--> 255	Green Intensity (0% <--> 100%)
9	000 <--> 255	Blue Intensity (0% <--> 100%)
10	000 <--> 255	White Intensity (0% <--> 100%)
11	000 <--> 255	Linear CTO control
12	000 <--> 255	Marco color effect
13	000 <--> 011	<b>Function</b> No function
	012 <--> 024	Pan/Tilt speed control in fastest
	025 <--> 037	Pan/Tilt speed control in normal speed
	038 <--> 042	Curve linear dimmer
	043 <--> 047	Index linear dimmer
	048 <--> 052	Logarithm linear dimmer
	053 <--> 057	Sine linear dimmer
	058 <--> 062	Delay curve 1
	063 <--> 067	Delay curve 2
	068 <--> 072	Delay curve 3
	073 <--> 077	Default power
	078 <--> 102	LED power changes
	103 <--> 255	No function
14	000 <--> 255	Zoom (0% <--> 100%)
15	000 <--> 127	<b>Lens Rotation</b> Lens Rotation
	128 <--> 190	Counterclockwise Rotation (fast <--> slow)
	191 <--> 192	Stop Rotation
	193 <--> 255	Clockwise Rotation (slow <--> fast)
16	000 <--> 255	Shape choice: Choose the shape
17	000 <--> 255	Shape speed: Shape effect speed and direction control
18	000 <--> 255	Shape delay: Shape delay in auto run mode
19	000 <--> 255	Shape effect: Red dimmer
20	000 <--> 255	Shape effect: Green dimmer
21	000 <--> 255	Shape effect: Blue dimmer
22	000 <--> 255	Shape effect: White dimmer
23	000 <--> 255	Shape effect: Foreground dimmer
24	000 <--> 255	Shape effect: Background dimmer
25	000 <--> 255	Shape change: Shape effect
26	000 <--> 255	Shape offset: Shape offset
27	000 <--> 025	<b>Reset</b> No function
	026 <--> 076	Zoom and lens rotation motor reset in 5 seconds
	077 <--> 127	Pan and Tilt motor reset in 5 seconds
	128 <--> 255	All motors reset in 5 seconds

## DMX Values In-Depth (55-Channel Mode)

Ch.	Value	What It Does
1	000 <--> 255	Pan
3	000 <--> 255	Fine Pan
2	000 <--> 255	Tilt
4	000 <--> 255	Fine Tilt
5	000 <--> 255	Dimmer (0% <--> 100%)
6	000 <--> 003	<b>Strobe</b> LED off, Strobe off
	004 <--> 019	LED on, Strobe off
	020 <--> 119	LED on, Strobe (slow <--> fast)
	120 <--> 129	LED on, Strobe off
	130 <--> 245	Pulse strobe (slow <--> fast)
	246 <--> 255	LED on, Strobe off
7	000 <--> 255	Red Intensity (0% <--> 100%)
8	000 <--> 255	Green Intensity (0% <--> 100%)
9	000 <--> 255	Blue Intensity (0% <--> 100%)
10	000 <--> 255	White Intensity (0% <--> 100%)
11	000 <--> 255	Linear CTO control
12	000 <--> 255	Marco color effect
13	000 <--> 011	<b>Function</b> No function
	012 <--> 024	Pan/Tilt speed control in fastest
	025 <--> 037	Pan/Tilt speed control in normal speed
	038 <--> 042	Curve linear dimmer
	043 <--> 047	Index linear dimmer
	048 <--> 052	Logarithm linear dimmer
	053 <--> 057	Sine linear dimmer
	058 <--> 062	Delay curve 1
	063 <--> 067	Delay curve 2
	068 <--> 072	Delay curve 3
	073 <--> 077	Default power
	078 <--> 102	LED power changes
	103 <--> 255	No function
14	000 <--> 255	Zoom (0% <--> 100%)
15	000 <--> 127	<b>Lens Rotation</b> Lens Rotation
	128 <--> 190	Counterclockwise Rotation (fast <--> slow)
	191 <--> 192	Stop Rotation
	193 <--> 255	Clockwise Rotation (slow <--> fast)
16	000 <--> 255	Shape choice: Choose the shape
17	000 <--> 255	Shape speed: Shape effect speed and direction control
18	000 <--> 255	Shape delay: Shape delay in auto run mode
19	000 <--> 255	Shape effect: Red dimmer
20	000 <--> 255	Shape effect: Green dimmer
21	000 <--> 255	Shape effect: Blue dimmer
22	000 <--> 255	Shape effect: White dimmer
23	000 <--> 255	Shape effect: Foreground dimmer
24	000 <--> 255	Shape effect: Background dimmer
25	000 <--> 255	Shape change: Shape effect
26	000 <--> 255	Shape offset: Shape offset
27	000 <--> 025	<b>Reset</b> No function
	026 <--> 076	Zoom and lens rotation motor reset in 5 seconds
	077 <--> 127	Pan and Tilt motor reset in 5 seconds
	128 <--> 255	All motors reset in 5 seconds



## DMX Values In-Depth (55-Channel Mode), continued

Ch.	Value	What It Does
28	000 <--> 255	LED 1 - Red Intensity (0% <--> 100%)
29	000 <--> 255	LED 1 - Green Intensity (0% <--> 100%)
30	000 <--> 255	LED 1 - Blue Intensity (0% <--> 100%)
31	000 <--> 255	LED 1 - White Intensity (0% <--> 100%)
32	000 <--> 255	LED 2 - Red Intensity (0% <--> 100%)
33	000 <--> 255	LED 2 - Green Intensity (0% <--> 100%)
34	000 <--> 255	LED 2 - Blue Intensity (0% <--> 100%)
35	000 <--> 255	LED 2 - White Intensity (0% <--> 100%)
36	000 <--> 255	LED 3 - Red Intensity (0% <--> 100%)
37	000 <--> 255	LED 3 - Green Intensity (0% <--> 100%)
38	000 <--> 255	LED 3 - Blue Intensity (0% <--> 100%)
39	000 <--> 255	LED 3 - White Intensity (0% <--> 100%)
40	000 <--> 255	LED 4 - Red Intensity (0% <--> 100%)
41	000 <--> 255	LED 4 - Green Intensity (0% <--> 100%)
42	000 <--> 255	LED 4 - Blue Intensity (0% <--> 100%)
43	000 <--> 255	LED 4 - White Intensity (0% <--> 100%)
44	000 <--> 255	LED 5 - Red Intensity (0% <--> 100%)
45	000 <--> 255	LED 5 - Green Intensity (0% <--> 100%)
46	000 <--> 255	LED 5 - Blue Intensity (0% <--> 100%)
47	000 <--> 255	LED 5 - White Intensity (0% <--> 100%)
48	000 <--> 255	LED 6 - Red Intensity (0% <--> 100%)
49	000 <--> 255	LED 6 - Green Intensity (0% <--> 100%)
50	000 <--> 255	LED 6 - Blue Intensity (0% <--> 100%)
51	000 <--> 255	LED 6 - White Intensity (0% <--> 100%)
52	000 <--> 255	LED 7 - Red Intensity (0% <--> 100%)
53	000 <--> 255	LED 7 - Green Intensity (0% <--> 100%)
54	000 <--> 255	LED 7 - Blue Intensity (0% <--> 100%)
55	000 <--> 255	LED 7 - White Intensity (0% <--> 100%)

## Troubleshooting

Symptom	Solution
Fixture Auto-Shut Off	Check the fan in the fixture. If it is stopped or moving slower than normal, the unit may have shut itself off due to high heat. This is to protect the fixture from overheating. Clear the fan of obstructions, or return the unit for service.
Beam is Dim	Check optical system and clean excess dust/grime.
No Light Output	Check to ensure fixture is operating under correct mode, IE sound active/auto/DMX/Etc., if applicable.
No Power	Check fuse, AC cord and circuit for malfunction.
Blown Fuse	Check AC cord and circuit for damage, verify that moving parts are not restricted and that unit's ventilation is not obstructed
Slow Movement	Check that speed channels are set appropriately.
No Response to Audio	Verify that the fixture is in "Sound Active" mode.
Fixture Not Responding / Responding Erratically	Make sure all connectors are seated properly and securely. Use Only DMX Cables. Install a Terminator. Check all cables for defects. Reset fixture(s).

# 5. APPENDIX

## A Quick Lesson On DMX

DMX (aka DMX-512) was created in 1986 by the United States Institute for Theatre Technology (USITT) as a standardized method for connecting lighting consoles to lighting dimmer modules. It was revised in 1990 and again in 2000 to allow more flexibility. The Entertainment Services and Technology Association (ESTA) has since assumed control over the DMX512 standard. It has also been approved and recognized for ANSI standard classification.

DMX covers (and is an abbreviation for) Digital MultipleXed signals. It is the most common communications standard used by lighting and related stage equipment.

DMX provides up to 512 control "channels" per data link. Each of these channels was originally intended to control lamp dimmer levels. You can think of it as 512 faders on a lighting console, connected to 512 light bulbs. Each slider's position is sent over the data link as an 8-bit number having a value between 0 and 255. The value 0 corresponds to the light bulb being completely off while 255 corresponds to the light bulb being fully on.

DMX data is transmitted at 250,000 bits per second using the RS-485 transmission standard over two wires. As with microphone cables, a grounded cable shield is used to prevent interference with other signals.

There are five pins on a DMX connector: a wire for ground (cable shield), two wires for "Primary" communication which goes from a DMX source to a DMX receiver, and two wires for a "Secondary" communication which goes from a DMX receiver back to a DMX source. Generally, the "Secondary" channel is not used so data flows only from sources to receivers. Hence, most of us are most familiar with DMX-512 as being employer over typical 3-pin "mic cables," although this does not conform to the defined standard.

DMX is connected using a daisy-chain configuration where the source connects to the input of the first device, the output of the first device connects to the input of the next device, and so on. The standard allows for up to 32 devices on a single DMX link.

Each receiving device typically has a means for setting the "starting channel number" that it will respond to. For example, if two 6-channel fixtures are used, the first fixture might be set to start at channel 1 so it would respond to DMX channels 1 through 6, and the next fixture would be set to start at channel 7 so it would respond to channels 7 through 12.

The greatest strength of the DMX communications protocol is that it is very simple and robust. It involves transmitting a reset condition (indicating the start of a new "packet"), a start code, and up to 512 bytes of data. Data packets are transmitted continuously. As soon as one packet is finished, another can begin with no delay if desired (usually another follows within 1 ms). If nothing is changing (i.e. no lamp levels change) the same data will be sent out over and over again. This is a great feature of DMX -- if for some reason the data is not interpreted the first time around, it will be re-sent shortly.

Not all 512 channels need to be output per packet, and in fact, it is very uncommon to find all 512 used. The fewer channels are used, the higher the "refresh" rate. It is possible to get DMX refreshes at around 1000 times per second if only 24 channels are being transmitted. If all 512 channels are being transmitted, the refresh rate is around 44 times per second.

In summary, since its design and evolution in the 1980's DMX has become the standard for lighting control. It is flexible, robust, and scalable, and its ability to control everything from dimmer packs to moving lights to foggers to lasers makes it an indispensable tool for any lighting designer or lighting performer.

## Keeping Your Stiletto™ I7 As Good As New

The fixture you've received is a rugged, tough piece of pro lighting equipment, and as long as you take care of it, it will take care of you. That said, like anything, you'll need to take care of it if you want it to operate as designed. You should absolutely keep the fixture clean, especially if you are using it in an environment with a lot of dust, fog, haze, wild animals, wild teenagers or spilled drinks.

Cleaning the optics routinely with a suitable glass cleaner will greatly improve the quality of light output. Keeping the fans free of dust and debris will keep the fixture running cool and prevent damage from overheating.

In transit, keep the fixtures in cases. You wouldn't throw a prized guitar, drumset, or other piece of expensive gear into a gear trailer without a case, and similarly, you shouldn't even think about doing it with your shiny new light fixtures.

Common sense and taking care of your fixtures will be the single biggest thing you can do to keep them running at peak performance and let you worry about designing a great light show, putting on a great concert, or maximizing your client's satisfaction and "wow factor." That's what it's all about, after all!

### Returns (Gasp!)

We've taken a lot of precautions to make sure you never even have to worry about sending a defective unit back, or sending a unit in for service. But, like any complex piece of equipment designed and built by humans, once in a while, something doesn't go as planned. If you find yourself with a fixture that isn't behaving like a good little fixture should, you'll need to obtain a Return Authorization (RA).

Don't worry, this is easy. Just go to our website and open a support ticket at [www.blizzardlighting.com/support](http://www.blizzardlighting.com/support), and we'll issue you an RA. Then, you'll need to send the unit to us using a trackable, pre-paid freight method. We suggest using USPS Priority or UPS. Make sure you carefully pack the fixture for transit, and whenever possible, use the original box & packing for shipping.

When returning your fixture for service, be sure to include the following:

- 1.) Your contact information (Name, Address, Phone Number, Email address).
- 2.) The RA# issued to you
- 3.) A brief description of the problem/symptoms.

We will, at our discretion, repair or replace the fixture. Please remember that any shipping damage which occurs in transit to us is the customer's responsibility, so pack it well!

### Shipping Issues

**Damage incurred in shipping is the responsibility of the shipper, and must be reported to the carrier immediately upon receipt of the items. Claims must be made within seven (7) days of receipt.**

## Tech Specs!

<b>Weight &amp; Dimensions</b>	
Width	11.8 inches (30 cm)
Depth	8.3 inches (21 cm)
Height	15 inches (38 cm)
Weight	9.3 lbs. (4.2 kg)
<b>Power</b>	
Operating Voltage	100-240VAC 50/60Hz
Power Consumption	152W, 1.92A, PF: .65
<b>Light Source</b>	
LED	7x15W High Power OSRAM 4-in-1 LEDs
<b>Optical</b>	
Beam Angle	4-60°
Luminous Intensity	31,869 Lux @ 2m (narrow), 1,587 Lux @ 2m (wide), 3,404 Lux @ 5m (narrow)
<b>Movement Range</b>	
Pan	540 degrees
Tilt	270 degrees
<b>Thermal</b>	
Max. Operating Temp.	104 degrees F (40 degrees C) ambient
<b>Control</b>	
Protocol	USITT DMX-512
DMX Channels	27/55-channels
Input	3-pin XLR Male
Output	3-pin XLR Female
Other Operating Modes	Standalone, Master/Slave, Auto, Sound Active
<b>Other Information</b>	
Due to Zika concerns, I'm reluctantly draining my moat.	
<b>Warranty</b>	2-year limited warranty, does not cover malfunction caused by damage to LEDs.

**DISCLAIMER:**

The power connector fitted to the fixture and fixture cord are designed for compatibility with products manufactured by Neutrik AG, Neutrik USA and their related entities, however they are not manufactured by, affiliated with or endorsed by Neutrik AG, Neutrik USA, or any related entity. Neutrik® and power-CON® are registered trademarks of Neutrik AG.

# Dimensional Drawings

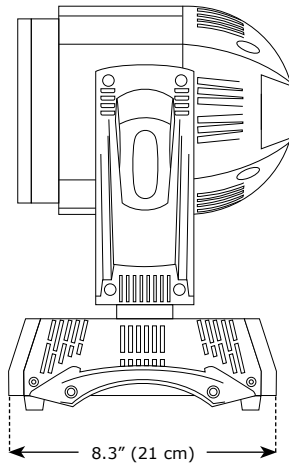
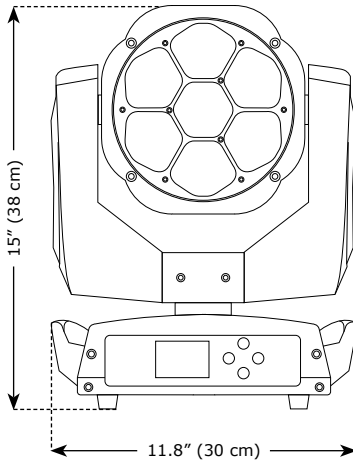

This page intentionally left blank.

This page intentionally left blank.



**Enjoy your product!  
Our sincerest thanks for your purchase!  
--The team @ Blizzard Lighting**