



Blizzard Lighting, LLC
<http://www.blizzardpro.com>
Waukesha, WI USA
Copyright (c) 2019

TABLE OF CONTENTS

Lux Capacitor™	1
1. Getting Started	3
What's In The Box?	3
Getting It Out Of The Box	3
Powering Up!	3
Getting A Hold Of Us	3
Safety Instructions (Don't Stick Your Hand In The Toaster!)	4
2. Meet The Lux Capacitor™	5
Main Features	5
DMX Quick Reference	5
The Lux Capacitor™ Pin-up Picture	6
3. Setup	7
Fuse Replacement	7
Connecting A Bunch Of Lux Capacitor™ Fixtures	7
Data/DMX Cables	7
Cable Connectors	8
3-Pin??? 5-Pin??? Huh?	8
Take It To The Next Level: Setting up DMX Control	8
Fixture Linking (Master/Slave Mode)	9
Mounting/Rigging	9
4. Operating Adjustments	10
The Control Panel	10
Control Panel Menu Structure	11
DMX Mode	11
Select The DMX Starting Address	11
Select The Channel Mode	11
Master/Slave Mode Settings	11
Auto Mode	12
Sound Active Mode	12
Manual Adjustments	12
Dimming Mode Settings	12
DMX Channel Values In-Depth	13
5. Appendix	14
Keeping Your Lux Capacitor™ As Good As New	14
Returns (Gasp!)	14
Shipping Issues	14
Tech Specs	15

1. GETTING STARTED

What's In The Box?

- 1 x Lux Capacitor™
- An Ever-So-Handy Power Cord
- A Sweet Safety Cable
- This Lovely User Manual

Getting It Out Of The Box

Congratulations on purchasing the Lux Capacitor™, the ultra-warm white retro blinder with intense background color effects. Now that you've got your Lux Capacitor™, you should carefully unpack the box and check the contents to ensure that all parts are present and in good condition. If anything looks as if it has been damaged in transit, notify the shipper immediately and keep the packing material for inspection. Again, please save the carton and all packing materials. If a fixture must be returned to the factory, it is important that the fixture be returned in the original factory box and packing.

Powering Up!

All fixtures must be powered directly off a switched circuit and **cannot be run off a rheostat (variable resistor) or dimmer circuit, even if the rheostat or dimmer channel is used solely for a 0% to 100% switch.**

AC Voltage Switch - Not all fixtures have a voltage select switch, so please verify that the fixture you receive is suitable for your local power supply. See the label on the fixture or refer to the fixture's specifications chart for more information. A fixture's listed current rating is its average current draw under normal conditions. Check the fixture or device carefully to make sure that if a voltage selection switch exists that it is set to the correct line voltage you will use.

Warning! Verify that the voltage select switch on your unit matches the line voltage applied. Damage to your fixture may result if the line voltage applied does not match the voltage indicated on the voltage selector switch. All fixtures must be connected to circuits with a suitable Ground (Earthing).

Getting A Hold Of Us

If something happens goes wrong, please visit www.blizzardpro.com/support and open a support ticket. We'll be happy to help, honest.

Disclaimer: The information and specifications contained in this document are subject to change without notice. Blizzard Lighting™ assumes no responsibility or liability for any errors or omissions that may appear in this user manual. Blizzard Lighting™ reserves the right to update the existing document or to create a new document to correct any errors or omissions at any time. You can download the latest version of this document from www.blizzardpro.com.

Author:	Date:	Last Edited:	Date:
J. Thomas	8/29/2019	J. Thomas	9/3/2019

SAFETY INSTRUCTIONS



Please read these instructions carefully. They include important information about the installation, usage and maintenance of this product.

- Please keep this User Guide for future use. If you sell the unit to someone else, be sure that they also receive this User Guide.
- ALWAYS make sure that you are connecting to the proper voltage, and that the line voltage you are connecting to is not higher than that stated on the decal or rear panel of the fixture.
- This product is intended for indoor use only.
- To prevent risk of fire or shock, do not expose fixture to rain or moisture.
- Make sure there are no flammable materials close to the unit while operating.
- The unit must be installed in a location with adequate ventilation, at least 20in (50cm) from adjacent surfaces. Be sure that no ventilation slots are blocked.
- ALWAYS disconnect from the power source before servicing or replacing fuse and be sure to replace with same fuse size and type.
- ALWAYS secure fixture using a safety chain. NEVER carry the fixture by its head. Use its carrying handles.
- DO NOT operate at ambient temperatures higher than 104°F (40°C).
- In the event of a serious operating problem, stop using the unit immediately. NEVER try to repair the unit by yourself. Repairs carried out by unskilled people can lead to damage or malfunction. Please contact the nearest authorized technical assistance center. Always use the same type spare parts.
- NEVER connect the device to a dimmer pack.
- Make sure the power cord is never crimped or damaged.
- Never disconnect the power cord by pulling or tugging on the cord.
- Avoid direct eye exposure to the light source while it is on.

Caution! There are no user serviceable parts inside the unit. Do not open the housing or attempt any repairs yourself. In the unlikely event your unit may require service, please open a support ticket at www.blizzardpro.com/support.

2. MEET THE LUX CAPACITOR™

MAIN FEATURES

- 3* 60W warm white LEDs (2200K)
- 48* 0.5W RGB LEDs (background effects)
- Individual control of warm white LEDs
- 30 speed controllable built-in programs
- Sound active mode available via standalone or DMX
- User-selectable 32-bit dimming curves
- Variable electronic dimming
- 1-25Hz strobe effects
- Flicker-free LEDs
- 3/5-pin DMX input/output connections
- PowerCon™ compatible AC power input/output connections

CONTROL:

- Protocol: USITT DMX-512
- DMX channels: 6/8/12-channel modes
- Easy-to-use 4-button control panel with LCD display
- Operating modes: DMX512, master/slave, auto, sound active

DMX Quick Reference (6/8/12-Channel Modes)

6CH	8CH	12CH	What It Does
--	--	1	Dimmer (0% <--> 100%)
1	1	2	Red Background (0% <--> 100%)
2	2	3	Green Background (0% <--> 100%)
3	3	4	Blue Background (0% <--> 100%)
4	4	5	WW LED Dimmer 1 (0% <--> 100%)
5	5	6	WW LED Dimmer 2 (0% <--> 100%)
6	6	7	WW LED Dimmer 3 (0% <--> 100%)
--	7	--	Dimmer (0% <--> 100%)
--	8	8	Strobe
--	--	9	Built-in Programs 1
--	--	10	Built-in Programs 2
--	--	11	Built-in Program Speed (slow <--> fast)
--	--	12	Sound Active Mode (sensitivity: high <--> low)

Figure 1: The Lux Capacitor™ Pin-Up Picture

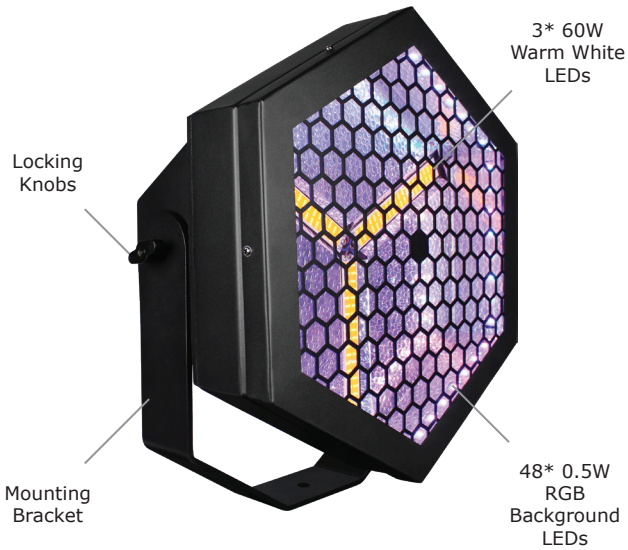
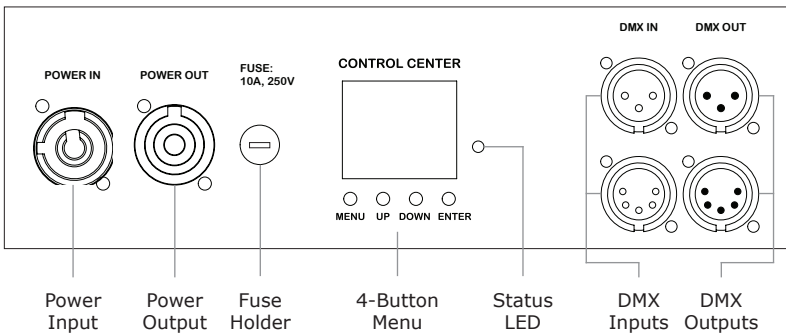

Figure 2: The Rear Connections



3. SETUP



Before replacing the fuse, disconnect the power cord.
ALWAYS replace it with the same type and rating.

Fuse Replacement

Remove the fuse holder from of its housing. Then take out the damaged fuse from its holder and replace with exact same type of fuse. Reattach the fuse holder, and then reconnect power.

Connecting A Bunch of Lux Capacitor™ Fixtures

You will need a serial data link to run light shows using a DMX-512 controller or to run shows on two or more fixtures set to sync in master/slave operating mode. The combined number of channels required by all the fixtures on a serial data link determines the number of fixtures the data link can support.

Fixtures on a serial data link must be daisy chained in one single line. Also, connecting more than 32 fixtures on one serial data link without the use of a DMX optically-isolated splitter may result in deterioration of the digital DMX signal. The maximum recommended cable-run distance is 500 meters (1640 ft). The maximum recommended number of fixtures on a serial data link is 32 fixtures.

Data/DMX Cabling

To link fixtures together you'll need data cables. You should use data-grade cables that can carry a high quality signal and are less prone to electromagnetic interference.

For instance, Belden© 9841 meets the specifications for EIA RS-485 applications. Standard microphone cables will "probably" be OK, but note that they cannot transmit DMX data as reliably over long distances. In any event, the cable should have the following characteristics:

*2-conductor twisted pair plus a shield
Maximum capacitance between conductors – 30 pF/ft.
Maximum capacitance between conductor & shield – 55 pF/ft.
Maximum resistance of 20 ohms / 1000 ft.
Nominal impedance 100 – 140 ohms*

Cable Connectors

Cables must have a male XLR connector on one end and a female XLR connector on the other end. (Duh!)

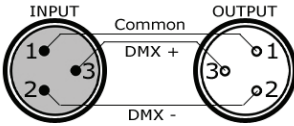

A Word on Termination: DMX is a resilient communication protocol, however errors still occasionally occur. Termination reduces signal errors, and therefore best practices include use of a terminator in all circumstances. If you are experiencing problems with erratic fixture behavior, especially over long signal cable runs, a terminator may help improve performance.

To build your own DMX Terminator:
Obtain a 120-ohm, 1/4-watt resistor, and wire it between pins 2 & 3 of the last fixture. They are also readily available from specialty retailers.

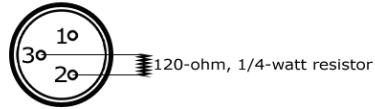

CAUTION: Do not allow contact between the common and the fixture's chassis ground. Grounding the common can cause a ground loop, and your fixture may perform erratically. Test cables with an ohm meter to verify correct polarity and to make sure the pins are not grounded or shorted to the shield or each other.

3-Pin??? 5-Pin??? Huh?!?

If you use a controller with a 5-pin DMX output connector, it's no problem! You can simply use the installed 5-pin DMX input and/or output connections found on the back of your fixture(s).

Conductor	3-Pin Female (Output)	5-Pin Male (Input)
Ground/Shield	Pin 1	Pin 1
Data 1- (Primary Data Link)	Pin 2	Pin 2
Data 1+ (Primary Data Link)	Pin 3	Pin 3
Data 2- (Optional Secondary Data Link)	Pin 4	Pin 4
Data 2+ (Optional Secondary Data Link)	Pin 5	Pin 5

Take It To The Next Level: Setting Up DMX Control

Step 1: Connect the male connector of the DMX cable to the female connector (output) on the controller.

Step 2: Connect the female connector of the DMX cable to the first fixture's male connector (input). *Note:* It doesn't matter which fixture address is the first one connected. We recommend connecting the fixtures in terms of their proximity to the controller, rather than connecting the lowest fixture number first, and so on.

Step 3: Connect other fixtures in the chain from output to input as above. Place a DMX terminator on the output of the final fixture to ensure best communication.

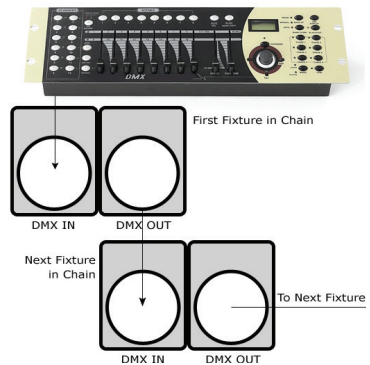

Fixture Linking (Master/Slave Mode)

1. Connect the (male) 3/5-pin connector side of the DMX cable to the output (female) 3/5-pin connector of the first fixture.
2. Connect the end of the cable coming from the first fixture which will have a (female) 3/5-pin connector to the input connector of the next fixture consisting of a (male) 3/5-pin connector. Then, proceed to connect from the output as stated above to the input of the following fixture and so on.

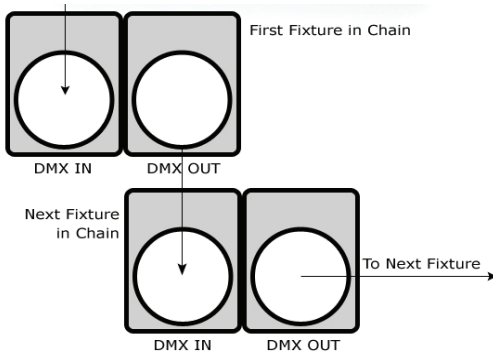

A quick note: Often, the setup for Master-Slave and Standalone operation requires that the first fixture in the chain be initialized for this purpose via either settings in the control panel or DIP-switches. Secondly, the fixtures that follow may also require a slave setting.

Check the **"Operating Adjustments"** section in this manual for complete instructions for this type of setup and configuration.

Mounting & Rigging

This fixture may be mounted in any SAFE position provided there is enough room for ventilation.

It is important never to obstruct the fan or vents pathway. Mount the fixture using a suitable "C" or "O" type clamp. The clamp should be rated to hold at least 10x the fixture's weight to ensure structural stability. Do not mount to surfaces with unknown strength, and ensure properly "rated" rigging is used when mounting fixtures overhead.

Adjust the angle of the fixture by loosening both knobs and tilting the fixture. After finding the desired position, retighten both knobs.

- When selecting installation location, take into consideration lamp replacement access (if applicable) and routine maintenance.
- Safety cables **MUST ALWAYS** be used.
- Never mount in places where the fixture will be exposed to rain, high humidity, extreme temperature changes or restricted ventilation.

4. OPERATING ADJUSTMENTS

The Control Panel

All the features and different modes possible with the Lux Capacitor™ are accessed by using the control panel. There are 4 control buttons below the display which allow you to navigate through the various control panel menus.

<MENU>

Is used to navigate to the previous higher-level menu item.

<UP>

Scrolls through menu items and numbers in ascending order.

<DOWN>

Scrolls through menu items and numbers in descending order.

<ENTER>

Is used to select and confirm/store the current selection.



The control panel LED display shows the menu items you select from the menu map on page #11. When a menu function is selected, the display will show immediately the first available option for the selected menu function. To select a menu item, press **<ENTER>**.

Use the **<UP>** and **<DOWN>** buttons to navigate the menu options. Press the **<ENTER>** button to select the menu function currently displayed, or to enable a menu option. To return to the previous option or menu without changing the value, press the **<MENU>** button.

Control Panel Menu Structure

Address	001-512	To choose the DMX address	
RunMode	DMX	06CH	To run in 6-channel mode
		08CH	To run in 8-channel mode
		12CH	To run in 12-channel mode
	Manual Test	Lamp 1	Red Background, 0-255 (0% <-> 100%)
		Lamp 2	Green Background, 0-255 (0% <-> 100%)
		Lamp 3	Blue Background, 0-255 (0% <-> 100%)
		Lamp 4	Lamp 1, 0-255 (0% <-> 100%)
		Lamp 5	Lamp 2, 0-255 (0% <-> 100%)
		Lamp 6	Lamp 3, 0-255 (0% <-> 100%)
		Dimmer	Dimmer, 0-255 (0% <-> 100%)
		Shutter	000-003 - No Function 004-007 - Dimmer 008-076 - Synchronized strobe (slow <-> fast) 077-145 - Pulse strobe (slow <-> fast) 146-215 - Random strobe (slow <-> fast) 216-255 - Dimmer
	Program	Program Speed	001-009 (fast <-> slow)
		Program Num	001-015 (select a program 1-15)
Sound	<ENTER>	Sound active mode	
Setting	Screen Reverse	YES	ON, rotation of the display by 180°
		NO	OFF
	Lamp Light Set	<ENTER>	000-255 (0% <-> 100%)
	Language	EN	English
		CN	Chinese
	Sensitivity	<ENTER>	Mic sensitivity, 000-255 (0% <-> 100%)
	Dimmer Mode	Slow	Slow dimming speed
		Fast	Fast dimming speed
	Dimmer Curve	LNR	Linear dimming
		SIN	S-curve
I1S		Square law curve	
I2S		Inverse square law curve	
SysInfo	V2.0	<ENTER> Software version information	

DMX Mode

Allows the unit to be controlled by any universal DMX controller.

Select the Starting DMX Address

- 1.) Navigate the main menu to reach **Address**, press <ENTER>.
- 2.) Use the <UP/DOWN> buttons to choose a starting DMX address ranging from 001-512, press <ENTER> to confirm, or <MENU> to exit.

Select the Channel Mode

- 1.) Navigate the main menu to reach **RunMode**, press <ENTER>.
- 2.) Then use the <UP/DOWN> buttons to highlight **DMX**.
- 3.) Scroll to either **06Ch**, **08Ch**, or **12Ch** and press <ENTER> to confirm.

Master/Slave Mode

- 1.) Daisy chain fixtures together via DMX input/output connections.
- 2.) The first fixture in the DMX chain is the master fixture, and the following units will operate in unison with the master.

Auto and Sound Active Modes:

Allows a single or Master/Slaved units to run factory installed programs.

Auto Mode

- 1.) Navigate the main menu to reach **RunMode**, press **<ENTER>**.
- 2.) Use the **<UP/DOWN>** buttons to highlight **Program**, press **<ENTER>**.
- 3.) Then highlight **Program Num**, press **<ENTER>**.
- 4.) Select a program value ranging from **001-015** and press **<ENTER>**.
- 5.) To adjust the speed, highlight **Program Speed**, press **<ENTER>**.
- 6.) Highlight any value from **001-009** (fast <-> slow), and press **<ENTER>**.

Sound Active Mode

- 1.) Navigate the main menu to reach **RunMode**, press **<ENTER>**.
- 2.) Use the **<UP/DOWN>** buttons to highlight **Sound**, press **<ENTER>**.
- 3.) To adjust the mic sensitivity, press **<MENU>** to return to the main menu.
- 4.) Navigate the main menu to reach **Setting**, press **<ENTER>**.
- 5.) Then highlight **Sensitivity**, press **<ENTER>**.
- 6.) Highlight any value from **000-255** (0% <-> 100%), and press **<ENTER>**.

Manual Adjustments

Allows individual adjustments to be made via the control panel menu.

Manual Test

- 1.) Navigate the main menu to reach **RunMode**, press **<ENTER>**.
- 2.) Use the **<UP/DOWN>** buttons to highlight **Manual Test**, press **<ENTER>**.
- 3.) Highlight any available option, and press **<ENTER>**.
- 4.) Select from **000-255**, and press **<ENTER>** (see *DMX Values In-Depth*).

Dimming Mode Settings:

Allows users to set the dimming speed, and use 1 of 4 different dimming curve settings for smoother (and slower) dimming capabilities.

Dimmer Curves

- 1.) Navigate the main menu to reach **Settings**, press **<ENTER>**.
- 2.) Use the **<UP/DOWN>** buttons to highlight **Dimmer Curve**, press **<ENTER>**.
- 3.) Now use the **<UP/DOWN>** buttons to highlight **LNR**, **SIN**, **I1S**, or **I2S**.
- 4.) Press the **<ENTER>** button to confirm your selection.

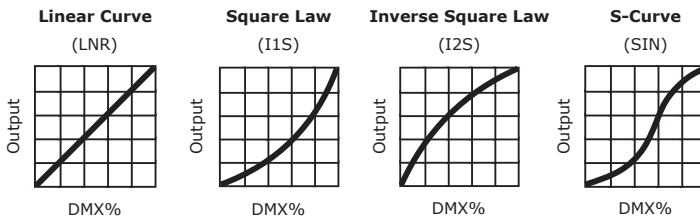

Dimmer Mode

- 1.) Navigate the main menu to reach **Settings**, press **<ENTER>**.
- 2.) Use the **<UP/DOWN>** buttons to highlight **Dimmer Mode**, press **<ENTER>**.
- 3.) Highlight either **Fast** or **Slow**, and press **<ENTER>** to confirm.

DMX Values In-Depth (6/8/12-Channel Modes)

6CH	8CH	12CH	Value	What It Does
--	--	1	000 <--> 255	Dimmer (0% <--> 100%)
1	1	2	000 <--> 255	Red Background (0% <--> 100%)
2	2	3	000 <--> 255	Green Background (0% <--> 100%)
3	3	4	000 <--> 255	Blue Background (0% <--> 100%)
4	4	5	000 <--> 255	WW LED Dimmer 1 (0% <--> 100%)
5	5	6	000 <--> 255	WW LED Dimmer 2 (0% <--> 100%)
6	6	7	000 <--> 255	WW LED Dimmer 3 (0% <--> 100%)
--	7	--	000 <--> 255	Dimmer (0% <--> 100%)
--	8	8	000 <--> 003 004 <--> 007 008 <--> 076 077 <--> 145 146 <--> 215 216 <--> 255	Strobe Closed Open Strobe (slow <--> fast) Rapid Pulses (slow <--> fast) Flashing (slow <--> fast) Open
--	--	9	000 <--> 015 016 <--> 031 032 <--> 047 048 <--> 063 064 <--> 079 080 <--> 095 096 <--> 111 112 <--> 127 128 <--> 143 144 <--> 159 160 <--> 175 176 <--> 191 192 <--> 207 208 <--> 223 224 <--> 239 240 <--> 255	Built-in Programs 1 (<i>Overrides Built-in Programs 2</i>) No Function Program 1 Program 2 Program 3 Program 4 Program 5 Program 6 Program 7 Program 8 Program 9 Program 10 Program 11 Program 12 Program 13 Program 14 Program 15
--	--	10	000 <--> 015 016 <--> 031 032 <--> 047 048 <--> 063 064 <--> 079 080 <--> 095 096 <--> 111 112 <--> 127 128 <--> 143 144 <--> 159 160 <--> 175 176 <--> 191 192 <--> 207 208 <--> 223 224 <--> 239 240 <--> 255	Built-in Programs 2 No Function Program 1 Program 2 Program 3 Program 4 Program 5 Program 6 Program 7 Program 8 Program 9 Program 10 Program 11 Program 12 Program 13 Program 14 Program 15
--	--	11	000 <--> 255	Built-in Program Speed (slow <--> fast)
--	--	12	000 <--> 255	Sound Active Mode (sensitivity: high <--> low)

5. APPENDIX

Keeping Your Lux Capacitor™ As Good As New

The fixture you've received is a rugged, tough piece of pro lighting equipment, and as long as you take care of it, it will take care of you. That said, like anything, you'll need to take care of it if you want it to operate as designed. You should absolutely keep the fixture clean, especially if you are using it in an environment with a lot of dust, fog, haze, wild animals, wild teenagers or spilled drinks.

Cleaning the optics routinely with a suitable glass cleaner will greatly improve the quality of light output. Keeping the fans free of dust and debris will keep the fixture running cool and prevent damage from overheating.

In transit, keep the fixtures in cases. You wouldn't throw a prized guitar, drum-set, or other piece of expensive gear into a gear trailer without a case, and similarly, you shouldn't even think about doing it with your shiny new light fixtures.

Common sense and taking care of your fixtures will be the single biggest thing you can do to keep them running at peak performance and let you worry about designing a great light show, putting on a great concert, or maximizing your client's satisfaction and "wow factor." That's what it's all about, after all!

Returns (Gasp!)

We've taken a lot of precautions to make sure you never even have to worry about sending a defective unit back, or sending a unit in for service. But, like any complex piece of equipment designed and built by humans, once in a while, something doesn't go as planned. If you find yourself with a fixture that isn't behaving like a good little fixture should, you'll need to obtain a Return Authorization (RA).

Don't worry, this is easy. Just visit www.blizzardpro.com/support and open a support ticket, and we'll issue you an RA. Then, you'll need to send the unit to us using a trackable, pre-paid freight method. We suggest using USPS Priority or UPS. Make sure you carefully pack the fixture for transit, and whenever possible, use the original box & packing for shipping.

When returning your fixture for service, be sure to include the following:

- 1.) Your contact information (Name, Address, Phone Number, Email address).
- 2.) The RA# issued to you
- 3.) A brief description of the problem/symptoms.

We will, at our discretion, repair or replace the fixture. Please remember that any shipping damage which occurs in transit to us is the customer's responsibility, so pack it well!

Shipping Issues

Damage incurred in shipping is the responsibility of the shipper, and must be reported to the carrier immediately upon receipt of the items. Claims must be made within seven (7) days of receipt.

Tech Specs!

Weight & Dimensions	
Width	12.6 inches (320mm)
Depth	6.5 inches (164mm)
Height	16 inches (405mm)
Weight	11.7 lbs (5.3 kg)
Power	
Operating Voltage	110-240VAC, 47-63 Hertz
Power Consumption	274W, 2.49A, PF: .99
Light Source	
LED	3* 60W warm white LEDs (2200K) 48* 0.5W RGB LEDs (background effects)
Optical	
Luminous Intensity	436 Lux @ 2.5m 121 Lux @ 5m
Thermal	
Max. Operating Temp.	104 degrees F (40 degrees C) ambient
Control	
Protocol	USITT DMX-512
DMX Channels	6/8/12-channel modes
Input/Output	3/5-pin XLR Male/Female
Other Operating Modes	DMX512, master/slave, auto, sound active
Warranty	
	2-year limited warranty, does not cover malfunction caused by damage to LEDs.

DISCLAIMER:

The power connector fitted to the fixture and fixture cord are designed for compatibility with products manufactured by Neutrik AG, Neutrik USA and their related entities, however they are not manufactured by, affiliated with or endorsed by Neutrik AG, Neutrik USA, or any related entity. Neutrik® and power-CON® are registered trademarks of Neutrik AG.

Dimensional Drawings

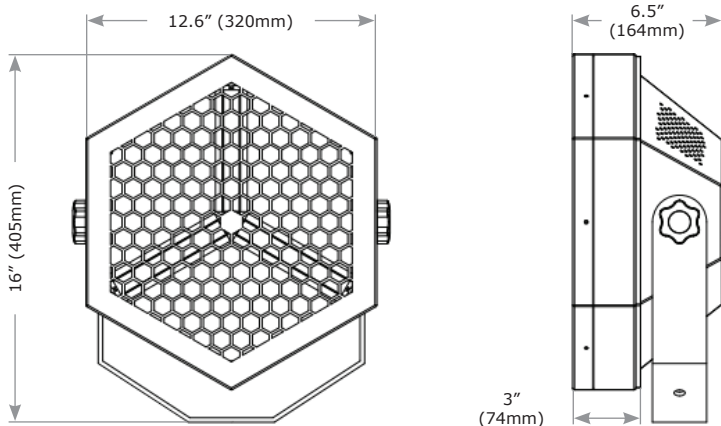



**Enjoy your product!
Our sincerest thanks for your purchase!
--The team @ Blizzard Lighting**