



Blizzard Lighting, LLC
www.blizzardlighting.com
Waukesha, WI USA
Copyright (c) 2017

TABLE OF CONTENTS

LB Bar™ CSI	1
1. Getting Started	3
What's In The Box?	3
Getting It Out Of The Box	3
Powering Up!	3
Getting A Hold Of Us	3
Safety Instructions	4
2. Meet The LB™ Bar CSI	3
Features	5
DMX Quick Reference	5
The LB™ Bar CSI Pin-up Picture	6
3. Setup	7
Fuse Replacement	7
Connecting Other LB™ Bar CSI Fixtures	7
Data/DMX Cables	7
Cable Connectors	8
Take It To The Next Level: Setting up DMX Control	8
Fixture Linking (Master/Slave Mode)	9
Mounting/Rigging	9
4. Operating Adjustments	10
Navigating The Control Panel	10
Control Panel Menu Structure	11
Dimming Curves	11
DMX Mode	11
Select Channel Mode & Starting DMX Address	12
Master/Slave Mode	12
Manual Output Level Settings	12
Strobe Effects	12
Dimming Curve Settings	12
DMX Channel Values In-Depth	13
Troubleshooting	13
5. Appendix	14
A Quick DMX Lesson	14
Keeping Your LB™ Bar CSI As Good As New	14
Returns (Gasp!)	14
Shipping Issues	14
Tech Specs	15
Dimensional Drawings	15

1. GETTING STARTED

What's In The Box?

- 1 x LB™ Bar CSI LED Fixture
- 1 x Power Cord
- This User Manual

Getting It Out Of The Box

Congratulations aspiring crime fighter and/or psychedelic music aficionado for purchasing the LB™ Bar CSI! Now that you've got your LB™ Bar CSI (or hopefully, more!), you should carefully unpack the box and check the contents to ensure that all parts are present and in good condition. If anything looks as if it has been damaged in transit, notify the shipper immediately and keep the packing material for inspection. Again, please save the carton and all packing materials. If a fixture must be returned to the factory, it is important that the fixture be returned in the original factory box and packing.

Powering Up!

All fixtures must be powered directly off a switched circuit and **cannot be run off a rheostat (variable resistor) or dimmer circuit, even if the rheostat or dimmer channel is used solely for a 0% to 100% switch.**

AC Voltage Switch - Not all fixtures have a voltage select switch, so please verify that the fixture you receive is suitable for your local power supply. See the label on the fixture or refer to the fixture's specifications chart for more information. A fixture's listed current rating is its average current draw under normal conditions. Check the fixture or device carefully to make sure that if a voltage selection switch exists that it is set to the correct line voltage you will use.

Warning! Verify that the voltage select switch on your unit matches the line voltage applied. Damage to your fixture may result if the line voltage applied does not match the voltage indicated on the voltage selector switch. All fixtures must be connected to circuits with a suitable Ground (Earthing).

Getting A Hold Of Us

If something happens goes wrong, please visit www.blizzardlighting.com / support and open a support ticket. We'll be happy to help, honest.

Disclaimer: The information and specifications contained in this document are subject to change without notice. Blizzard Lighting™ assumes no responsibility or liability for any errors or omissions that may appear in this user manual. Blizzard Lighting™ reserves the right to update the existing document or to create a new document to correct any errors or omissions at any time. You can download the latest version of this document from www.blizzardlighting.com.

Author:	Date:	Last Edited:	Date:
J. Thomas	10/26/2017	J. Thomas	10/26/2017

SAFETY INSTRUCTIONS



Please read these instructions carefully. They include important information about the installation, usage and maintenance of this product.

- Please keep this User Guide for future use. If you sell the unit to someone else, be sure that they also receive this User Guide.
- ALWAYS make sure that you are connecting to the proper voltage, and that the line voltage you are connecting to is not higher than that stated on the decal or rear panel of the fixture.
- This product is intended for indoor use only.
- To prevent risk of fire or shock, do not expose fixture to rain or moisture.
- Make sure there are no flammable materials close to the unit while operating.
- The unit must be installed in a location with adequate ventilation, at least 20in (50cm) from adjacent surfaces. Be sure that no ventilation slots are blocked.
- ALWAYS disconnect from the power source before servicing or replacing fuse and be sure to replace with same fuse size and type.
- ALWAYS secure fixture using a safety chain. NEVER carry the fixture by its head. Use its carrying handles.
- DO NOT operate at ambient temperatures higher than 104°F (40°C).
- In the event of a serious operating problem, stop using the unit immediately. NEVER try to repair the unit by yourself. Repairs carried out by unskilled people can lead to damage or malfunction. Please contact the nearest authorized technical assistance center. Always use the same type spare parts.
- NEVER connect the device to a dimmer pack.
- Make sure the power cord is never crimped or damaged.
- Never disconnect the power cord by pulling or tugging on the cord.
- Avoid direct eye exposure to the light source while it is on.

Caution! There are no user serviceable parts inside the unit. Do not open the housing or attempt any repairs yourself. In the unlikely event your unit may require service, please open a support ticket at www.blizzardlighting.com/support.

2. MEET THE LB BAR™ CSI

MAIN FEATURES

- 9* high output 3-watt UV LEDs
- Emits a wide 110° beam angle
- User selectable 1 or 3 DMX channel modes
- Variable electronic dimming & strobe effects (1-20Hz)
- Standalone, master/slave and DMX modes
- 4-button LED control panel for easy programming
- Two or more bars of can be directly joined end-to-end
- 5 different dimming curves
- Dual mounting brackets allow flexibility in positioning
- Natural convection cooled, totally silent operation
- 3-pin male/female XLR input & output
- IEC power In/Out connections
- Lightweight and compact

DMX Quick Reference (1-Channel Mode)

Channel	What It Does
1	UV Intensity (0% <-> 100%)

DMX Quick Reference (3-Channel Mode)

Channel	What It Does
1	UV Intensity (0% <-> 100%)
2	Strobe (slow <-> fast)
3	Dimming Curves

Figure 1: The LB™ Bar CSI Pin-Up Picture

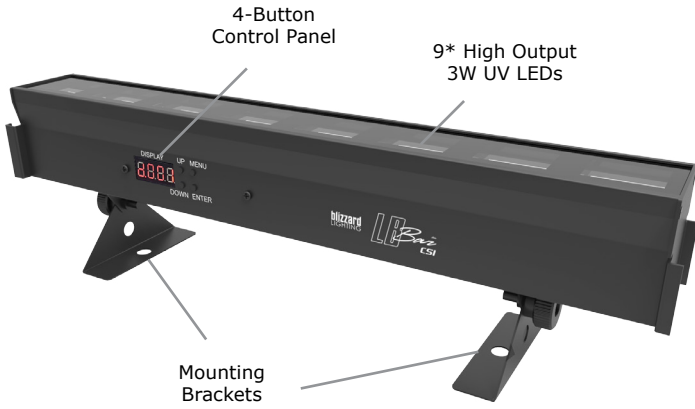
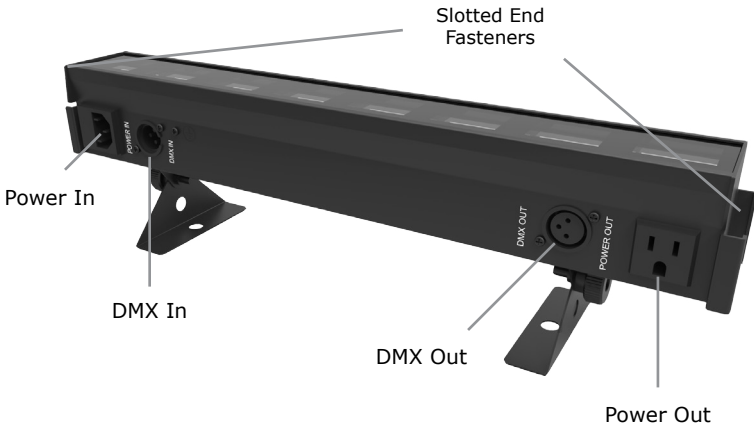

Figure 2: The Rear Connections



3. SETUP



Before replacing a fuse, disconnect the power cord.
ALWAYS replace with the same type and rating of fuse.

Fuse Replacement

With a flat head screwdriver, wedge the fuse holder out of its housing. Remove the damaged fuse from its holder and replace with exact same type fuse.

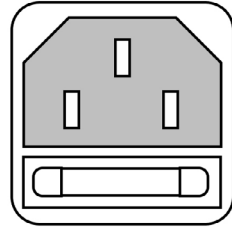

Connecting A Bunch of LB™ Bar CSI Fixtures

You will need a serial data link to run light shows using a DMX-512 controller or to run shows on two or more fixtures set to sync in master/slave operating mode. The combined number of channels required by all the fixtures on a serial data link determines the number of fixtures the data link can support.

Fixtures on a serial data link must be daisy chained in one single line. Also, connecting more than 32 fixtures on one serial data link without the use of a DMX optically-isolated splitter may result in deterioration of the digital DMX signal. The maximum recommended cable-run distance is 500 meters (1640 ft). The maximum recommended number of fixtures on a serial data link is 32 fixtures.

Data/DMX Cabling

You should use data-grade cables that can carry a high quality signal and are less prone to electromagnetic interference.

For instance, Belden© 9841 meets the specifications for EIA RS-485 applications. Standard microphone cables will “probably” be OK, but they cannot transmit DMX data as reliably over long distances. In any event, the cable should have the following characteristics:

2-conductor twisted pair plus a shield
Maximum capacitance between conductors – 30 pF/ft.
Maximum capacitance between conductor & shield – 55 pF/ft.
Maximum resistance of 20 ohms / 1000 ft.
Nominal impedance 100 – 140 ohms

Cable Connectors

Cables must have a male XLR connector on one end and a female XLR connector on the other end. (Duh!)

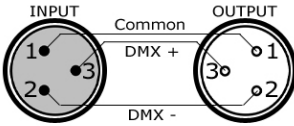

A Word on Termination: DMX is a resilient communication protocol, however errors still occasionally occur. Termination reduces signal errors, and therefore best practices include use of a terminator in all circumstances. If you are experiencing problems with erratic fixture behavior, especially over long signal cable runs, a terminator may help improve performance.

To build your own DMX Terminator:
Obtain a 120-ohm, 1/4-watt resistor, and wire it between pins 2 & 3 of the last fixture. They are also readily available from specialty retailers.

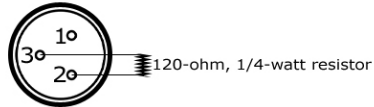

CAUTION: Do not allow contact between the common and the fixture's chassis ground. Grounding the common can cause a ground loop, and your fixture may perform erratically. Test cables with an ohm meter to verify correct polarity and to make sure the pins are not grounded or shorted to the shield or each other.

3-Pin??? 5-Pin??? Huh?!?

If you use a controller with a 5 pin DMX output connector, you will need to use a 5 pin to 3 pin adapter. They are widely available over the internet and from specialty retailers. If you'd like to build your own, the chart below details a proper cable conversion:

Ground/Shield	Pin 1	Pin 1
Data 1- (Primary Data Link)	Pin 2	Pin 2
Data 1+ (Primary Data Link)	Pin 3	Pin 3
Data 2- (Optional Secondary Data Link)	Pin 4	Pin 4
Data 2+ (Optional Secondary Data Link)	Pin 5	Pin 5

Take It To The Next Level: Setting Up DMX Control

Step 1: Connect the male connector of the DMX cable to the female connector (output) on the controller.

Step 2: Connect the female connector of the DMX cable to the first fixture's male connector (input). *Note:* It doesn't matter which fixture address is the first one connected. We recommend connecting the fixtures in terms of their proximity to the controller, rather than connecting the lowest fixture number first, and so on.

Step 3: Connect other fixtures in the chain from output to input as above. Place a DMX terminator on the output of the final fixture to ensure best communication.

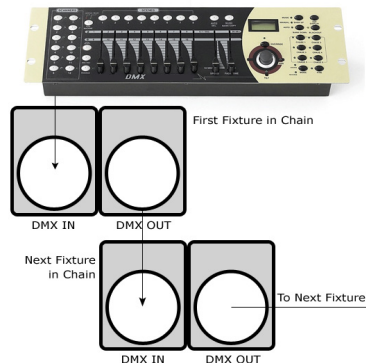

Fixture Linking (Master/Slave Mode)

1. Connect the (male) 3 pin connector side of the DMX cable to the output (female) 3 pin connector of the first fixture.
2. Connect the end of the cable coming from the first fixture which will have a (female) 3 pin connector to the input connector of the next fixture consisting of a (male) 3 pin connector. Then, proceed to connect from the output as stated above to the input of the following fixture and so on.

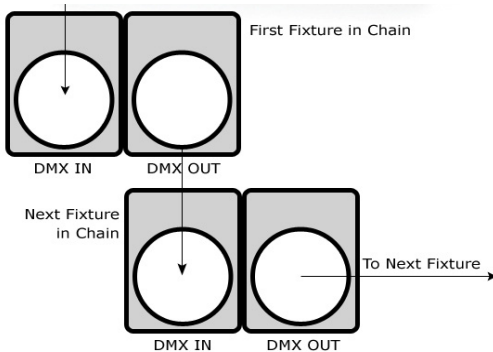

A quick note: Often, the setup for Master-Slave and Standalone operation requires that the first fixture in the chain be initialized for this purpose via either settings in the control panel or DIP-switches. Secondly, the fixtures that follow may also require a slave setting.

Check the **“Operating Adjustments”** section in this manual for complete instructions for this type of setup and configuration.

Mounting & Rigging

This fixture may be mounted in any SAFE position provided there is enough room for ventilation.

It is important never to obstruct the fan or vents pathway. Mount the fixture using a suitable “C” or “O” type clamp. The clamp should be rated to hold at least 10x the fixture’s weight to ensure structural stability. Do not mount to surfaces with unknown strength, and ensure properly “rated” rigging is used when mounting fixtures overhead.

Adjust the angle of the fixture by loosening both knobs and tilting the fixture. After finding the desired position, retighten both knobs.

- When selecting installation location, take into consideration lamp replacement access (if applicable) and routine maintenance.
- Safety cables **MUST ALWAYS** be used.
- Never mount in places where the fixture will be exposed to rain, high humidity, extreme temperature changes or restricted ventilation.

4. OPERATING ADJUSTMENTS

The Control Panel

All the features and different modes possible with the LB™ Bar CSI are accessed by using the control panel on the rear of the fixture. There are 4 control buttons below the LED display which allow you to navigate through the various control panel menus.

<MENU>

Is used to navigate to the previous higher-level menu item.

<UP>

Scrolls through menu items and numbers in ascending order.

<DOWN>

Scrolls through menu items and numbers in descending order.

<ENTER>

Is used to select and confirm/store the current selection.

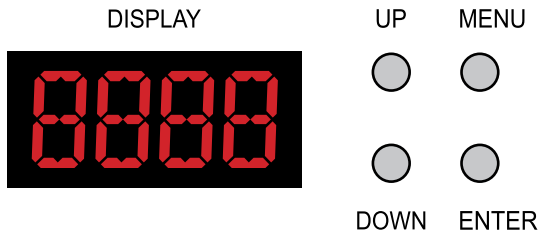

The control panel LED display shows the menu items you select from the menu map on page #11. When a menu function is selected, the display will show immediately the first available option for the selected menu function. To select a menu item, press **<ENTER>**.

Use the **<UP>** and **<DOWN>** buttons to navigate the menu options. Press the **<ENTER>** button to select the menu function currently displayed, or to enable a menu option. To return to the previous option or menu without changing the value, press the **<MENU>** button.

Control Panel Menu Structure

d3--	000 - 512	3-channel DMX mode
d.1--	000 - 512	1-channel DMX mode
n---	000 - 255	UV intensity (0% <--> 100%)
F---	000 - 255	Strobe speed (slow <--> fast)
dr--	dr-0	Linear dimming curve
	dr-1	Dimming curve 1
	dr-2	Dimming curve 2
	dr-3	Dimming curve 3
	dr-4	Dimming curve 4

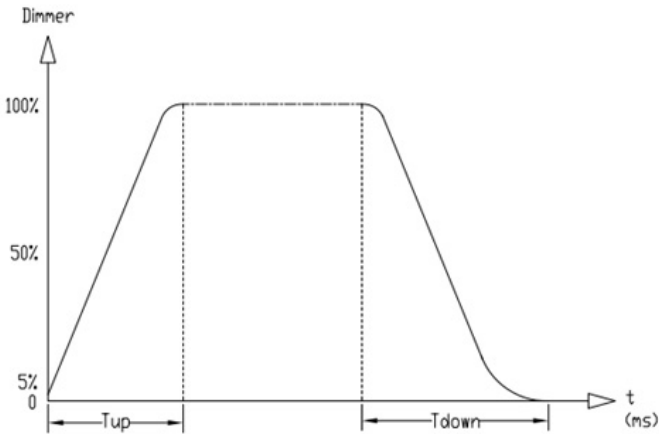

Dimming Curves

Ramp Effect	Menu	Tup(ms)	Tdown(ms)
Standard	dr-0	0	0
Curve 1	dr-1	980	1010
Curve 2	dr-2	1210	1320
Curve 3	dr-3	1600	1710
Curve 4	dr-4	1850	1980

DMX Mode

Allows the unit to be controlled by any universal DMX controller.

Select Channel Mode & Starting DMX Address:

- 1.) Navigate the main menu until you reach either **d3--** (3ch mode), or **d.1--** 1ch mode, and press **<ENTER>**.
- 2.) Use the **<UP/DOWN>** buttons to select a starting DMX address ranging from 1-512, and press the **<ENTER>** button to confirm.

Master/Slave Mode:

- 1.) Daisy chain fixtures DMX input/output connections.
- 2.) Set the DMX channel mode on fixtures to match either **d.3** or **d.1**.
- 3.) Set the starting DMX channel as needed.
- 2.) The first fixture in the DMX chain is the master fixture, and the following fixtures will follow the master.

Manual Output Level Settings:

Manually set the UV intensity output level as follows:

- 1.) Navigate the main menu until you reach **N--**, and press **<ENTER>**.
- 2.) Use the **<UP/DOWN>** buttons to adjust intensity level anywhere from **000-255** (0% <--> 100%).
- 3.) Press the **<ENTER>** button to confirm.

Strobe Effects

- 1.) Navigate the main menu until you reach **F---**, and press **<ENTER>**.
- 2.) Then use the **<UP/DOWN>** buttons to select a strobe speed setting from **0-255** (slow <--> fast).
- 3.) Press the **<ENTER>** button to confirm.

Dimming Curve Settings:

You can manually set the fixtures dimming curve of your choice:

- 1.) Navigate the main menu until you reach **dr--**, and press **<ENTER>**.
- 2.) Use the **<UP/DOWN>** buttons to highlight **dr-0** to **dr-04**.
- 3.) Press the **<ENTER>** button to confirm.

DMX Values In-Depth (3-Channel Mode)

Channel	Value	What It Does
1	000 <--> 255	UV Intensity (0% <--> 100%)
2	000 <--> 005 006 <--> 055 056 <--> 105 106 <--> 155 156 <--> 205 206 <--> 255	Strobe No Function Random Strobe Pulse Strobe Average Strobe Thunder Strobe Standard Strobe
3	000 <--> 020 021 <--> 040 041 <--> 060 061 <--> 080 081 <--> 100 101 <--> 255	Dimming Curves Standard Curve Dimming Curve 1 Dimming Curve 2 Dimming Curve 3 Dimming Curve 4 No Function

DMX Values In-Depth (1-Channel Mode)

Channel	Value	What It Does
1	000 <--> 255	UV Intensity (0% <--> 100%)

Troubleshooting

Symptom	Solution
Beam is Dim	Check optical system and clean excess dust/grime.
No Light Output	Check to ensure fixture is operating under correct mode.
Chase Speed Too Fast/Slow	Check to ensure proper setup of speed adjustment.
No Power	Check fuse, AC cord and circuit for malfunction.
Blown Fuse	Check AC cord and circuit for damage, verify that moving parts are not restricted and that unit's ventilation is not obstructed
No Response to Audio	Sound Active mode is not equipped with this fixture.
Fixture Not Responding / Responding Erratically	Make sure all connectors are seated properly and securely. Use Only DMX Cables and/or check cables for defects Install a Terminator. Reset fixture(s).

If your problem persists or isn't listed, please open a support ticket online at: www.blizzardlighting.com/support.

5. APPENDIX

Keeping Your LB Bar™ CSI As Good As New

The fixture you've received is a rugged, tough piece of pro lighting equipment, and as long as you take care of it, it will take care of you. You should absolutely keep the fixture clean, especially if you are using it in an environment with a lot of dust, fog, haze, wild animals, wild teenagers or spilled drinks.

Cleaning the optics routinely with a suitable glass cleaner will greatly improve the quality of light output. Keeping the fans free of dust and debris will keep the fixture running cool and prevent damage from overheating.

In transit, keep the fixtures in cases. You wouldn't throw a prized guitar, drumset, or other piece of expensive gear into a gear trailer without a case, and similarly, you shouldn't even think about doing it with your shiny new light fixtures.

Common sense and taking care of your fixtures will be the single biggest thing you can do to keep them running at peak performance and let you worry about designing a great light show, putting on a great concert, or maximizing your client's satisfaction and "wow factor." That's what it's all about, after all!

Returns (Gasp!)

We've taken a lot of precautions to make sure you never even have to worry about sending a defective unit back, or sending a unit in for service. But, like any complex piece of equipment designed and built by humans, once in a while, something doesn't go as planned. If you find yourself with a fixture that isn't behaving like a good little fixture should, you'll need to obtain a Return Authorization (RA).

Don't worry, this is easy. Just go to our website and open a support ticket at www.blizzardlighting.com/support, and we'll issue you an RA. Then, you'll need to send the unit to us using a trackable, pre-paid freight method. We suggest using USPS Priority or UPS. Make sure you carefully pack the fixture for transit, and whenever possible, use the original box & packing for shipping.

When returning your fixture for service, be sure to include the following:

- 1.) Your contact information (Name, Address, Phone Number, Email address).
- 2.) The RA# issued to you
- 3.) A brief description of the problem/symptoms.

We will, at our discretion, repair or replace the fixture. Please remember that any shipping damage which occurs in transit to us is the customer's responsibility, so pack it well!

Shipping Issues

Damage incurred in shipping is the responsibility of the shipper, and must be reported to the carrier immediately upon receipt of the items. Claims must be made within seven (7) days of receipt.

Tech Specs!

Weight & Dimensions	
Width	16.4 in (41.5 cm)
Depth	2.3 in (5.7 cm)
Height	4.3 in (10.9 cm)
Weight	1.7 lbs (.75 kg)
Power	
Operating Voltage	110-240VAC, 50-60 Hertz
Power Consumption	24W, .27A, PF: .65
Light Source	
LED	9* high output 3-watt UV LEDs
Optical	
Beam Angle	110 degree beam
Wavelength	393~396nm
Thermal	
Max. Operating Temp.	104 degrees F (40 degrees C) ambient
Control	
Protocol	USITT DMX-512
DMX Channels	1/3-channel
Input/Output	3-pin XLR Male/Female
Other Operating Modes	DMX512, M/S, Standalone Mode
Warranty	2-year limited warranty, does not cover malfunction caused by damage to LEDs.

Dimensional Drawings

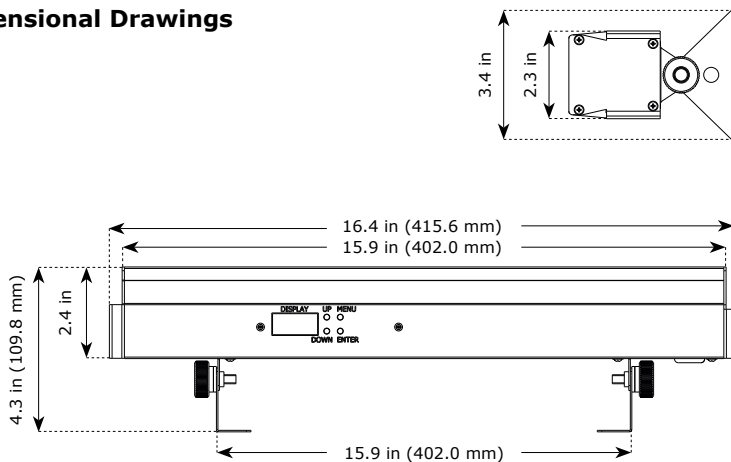



**Enjoy your product!
Our sincerest thanks for your purchase!
--The team @ Blizzard Lighting**